



Christian County Commission

100 West Church St, Room 100
Ozark, MO 65721

SCHEDULED

MEETING ATTACHMENTS (ID # 5405)

Meeting: 06/13/23 09:00 AM

Department: County Clerk

Category: Meeting Items

Prepared By: Madi Hires

Initiator: IQM2 Admin

Sponsors:

DOC ID: 5405

061323 Meeting Attachments

ATTACHMENTS:

- CERTIFIED COURT ORDER NO. 06-13-2023-01 (PDF)
- EMA - 2023 EMERGENCY MANAGEMENT PERFORMANCE GRANT (PDF)
- AWARD LETTER - POSTAGE FUNDING AGREEMENT - QUADIENT (PDF)
- STATE OF MISSOURI PARTICIPATING ADDENDUM FOR CONTRACT (PDF)
- STATE OF MISSOURI CONTRACT #CC221938008 (PDF)
- PRODUCT INFORMATION iX-1 (PDF)
- PRODUCT INFORMATION FOR iX-7DS (PDF)
- POSTAGE LINE OF CREDIT (PDF)
- POSTAGE LINE OF CREDIT FORM (PDF)
- QUADIENT LEASE FOR EQUIPMENT & MAINTENANCE (PDF)
- SIGNATURE PAGE SIGNED BY LEGAL COUNSEL - PG 1 (PDF)
- SIGNATURE PAGE SIGNED BY LEGAL COUNSEL - PG 2 (PDF)
- STATE OF MISSOURI CONTRACT PRICING - QUADIENT (PDF)
- PROSECUTING ATTORNEY - MOU WITH MISSOURI OFFICE OF PROSECUTION SERVICES (MOPS) (PDF)

Fax: 417-581-2368

Contact Information

Authorized Official

Enter the name and address of the individual who has the authority to legally bind the applicant agency.

· City Government - If the applicant agency is a city, the Mayor/City Administrator shall be the Authorized Official.

· County Government - If the applicant agency is a county, the Presiding Commissioner shall be the Authorized Official.

Authorized Official:* Presiding Commissioner Lynn Morris
Title First Name Last Name

Job Title:* Presiding Commissioner

Agency:* Christian County

Mailing Address:* 100 W. Church Room 100

Street Address:

City/State/Zip* Ozark Missouri 65721
City State Zip Code

Email:* lmorris@christiancountymo.gov

Phone:* 417-582-4300
Office Cell

Project Director

For EMPG grant the EMD is the Project Director.

Emergency Management Director:* Director Phil Amtower
Title First Name Last Name

Agency:* Christian County Emergency Management

Mailing Address:* 100 W. Church Room 100

Street Address: 110 W. Elm Room 60

City/State/Zip* Ozark Missouri 65721
City State Zip Code

Email:* philamtower@christiancountymo.gov

Phone:* 417-582-5400 417-209-5535
Office Cell

Fiscal Officer

For EMPG grants the City/County Treasurer is the Fiscal Officer.

Fiscal Officer:* Treasurer Karen Matthews
Title First Name Last Name

Job Title:* Christian County Treasurer

Agency:* Christian County

Mailing Address:* 100 W. Church Room 209

Street Address:

City/State/Zip* Ozark Missouri 65721
City State Zip Code
Email:* karenmatthews@christiancountymo.gov
Phone:* 417-582-4348
Office Cell

Project Contact Person

Is the Emergency Management Director and the Project Contact Person the same?* Yes
If the EMD & Project Contact are the same, it is not necessary to complete the Project Contact information.

Project Contact Person: Mr. Phil Amtower
Title First Name Last Name

Job Title: EMD
Agency: Christian County Emergency Management
Mailing Address: 100 W. Church Room 100
Street Address: 110 W. Elm, Room 60

City/State/Zip Ozark Missouri 65721
City State Zip Code
Email: philamtower@christiancountymo.gov
Phone: 417-582-5400
Office Cell

Project Narrative Justification

Project Title:* Emergency Management Performance Grant
Project Type:* Develop/enhance homeland security/emergency management organization and structure
The requested funds will be used to:* Sustainment of Existing Project
Select the primary Core Capability that will be supported by this proposed project.* Protection Planning

Project Narrative Summary*

Christian County EMA utilizes funding from the EMPG grant to aid in preparedness, operations, recovery and planning of the Christian County EM/EOC.

We will sustain, maintain and enhance the following: hardware/systems and phone/internet systems, Whole Community Planning & Recovery, NIMS Compliance with all county agencies, Continue development of THIRA/ Christian County Specific, Joint planning committee for County wide Exercises with all local entities, provide monthly educational training meetings for the public on Preparedness, County ID System oversight will be utilized on a daily bases to secure the county by identifying all county First Responders, County EMA also oversees EM activities for the cities of Ozark, Nixa, Fremont Hills, Clever, Sparta.

We provide Oversight for: CERT, Fire Corps, Medical Reserve Corps, DART, VIPS, and MOCERT1 (the regional CERT team).

We will maintain the current staffing level of the Director, Assistant Director, and Administrative Assistant to manage the EMA/EOC. This, among more, will be completed to ensure our preparedness, planning and recovery to protect the lives and property of the citizens of Christian County.

2000 Character Limit

Gap or Need Addressed*	EMA/EOC Operations and Mitigation
Project Objective*	Sustain Current Level of Operational Readiness
Anticipated Project Impact*	Ability to effectively mitigate, activate, respond to a disaster in our county. As well as support in whole community recovery measures.
<i>Select the Mission Areas that apply to this project. TO SELECT MULTIPLE CATEGORIES HOLD CONTROL DOWN WHILE SELECTING THEM.</i>	
Mission Area*	Prevention, Protection, Mitigation, Response, Recovery
<i>Select the POETE categories that apply to this project. TO SELECT MULTIPLE CATEGORIES HOLD CONTROL DOWN WHILE SELECTING THEM.</i>	
POETE Category*	P - Planning, O - Organization, E - Equipment, T - Training, E - Exercise
<i>Select the Identified Gap or Need reference document for this project. TO SELECT MULTIPLE CATEGORIES HOLD CONTROL DOWN WHILE SELECTING THEM.</i>	
Reference for Identified Gap or Need*	THIRA/SPR, Hazard Mitigation Plan, AAR/IP, Other Deliberate Plan

Performance Goals

Performance Goals*	Maintain/Sustain the current level of operations for our EMA/EOC.
Current Capability Metrics*	Provide operations, planning and disaster recovery efforts for our county and work closely with other local governmental and nongovernmental agencies.
Milestones*	Continue to provide operations, planning, and disaster recovery efforts for our county and work closely with other local governmental and nongovernmental agencies.

Performance Measures

Percent of capability-building EMPG Program-funded projects that align to capability gaps identified by states, territories, and urban areas in their SPR submissions.*	75
Percent of EMPG Program dollars spent on capability-building projects that align to capability gaps identified by states, territories, and urban areas in their SPR submissions.*	75
Percent of capability-building EMPG Program-funded projects that address a core capability that has one or more	50

targets rated as high priority. *

Percent of funding allocated to build or sustain capabilities in EMPG Program national priority areas and RA agreed-upon priority areas. * 100

Percent of Planning, Training and/or Exercise related projects that align with closing capability gaps identified and documented in the state/territory's most recent THIRA/SPR submission, Mitigation Plan, After Action Reports, Audits./Monitoring Findings, or other Deliberate Plans. * 100

Staffing Pattern

Position	Phil Amtower	Director Christian	01/01/1997
	Name	Title	Hire Date
Position	Vacant at present	Assistant Director	07/31/2023
	Name	Title	Hire Date
Position	Cheryl Mitchell	Administrative Assistant	01/03/2017
	Name	Title	Hire Date
Position			
	Name	Title	Hire Date
Position			
	Name	Title	Hire Date
Position			
	Name	Title	Hire Date
Position			
	Name	Title	Hire Date

Baseline Requirement #1- Emergency Operations Center (EOC)

EOC Location*	Justice Center			
EOC Street Address:*	110 West Elm, Room 60	Ozark	MO	65721
	Street Address	City	State	Zip Code
EOC Phone Number*	417-582-5400	417-582-5420		

	Primary EOC Number	EOC Alternate Phone Number		
EOC Contact Person*	Phil Amtower			
	Name			
Contact Person Address*	100 W. Church Room 100	Ozark	Mo	65721
	Street	City	State	Zip Code

Baseline Requirement #2- Local Emergency Operations Plan (LEOP)

I understand as a minimum requirement my awarded agency must update/review our LEOP every 2 years and maintain SEMA verification documents with identified changes.*

Yes

Date of Last LEOP update/review?*

11/04/2021

Have you provided your State Emergency Management Agency (SEMA) Area Coordinator with your agency's LEOP? *

Yes

Baseline Requirement #3- National Incident Management System (NIMS)

1. Has the jurisdiction formally adopted the National Incident Management System (NIMS) throughout the jurisdiction or organization to prevent, protect against, mitigate, respond to, and recover from incidents?*

Yes

2. Has the jurisdiction ensured training for the incident personnel incorporates NIMS training that is pertinent to each individuals incident responsibilities in alignment with the NIMS training program?*

Yes

3. Does the jurisdiction develop, maintain, and implement mutual aid agreements (to include agreements with the private sector and nongovernmental organizations)?*

Yes

4. Does the jurisdiction apply ICS as the standard approach to the on-scene command, control, and coordination of incidents? *

Yes

5. Does the jurisdiction enable effective and secure communications within and across jurisdictions and organizations?*

Yes

6. Does the jurisdiction identify and inventory deployable incident resources consistently with national NIMS resource typing definitions and job titles/position qualifications, available through the Resource Typing Library Tool?*

Yes

Baseline Requirement #4- Training Requirements

1. Have all EMPG funded personnel completed the minimum required FEMA trainings?*

Yes

IS 100, IS 120, IS 200, IS 230, IS 235, IS 240, IS 241, IS 242, IS 244, IS 700, IS 800.
Required completion within 12 months of hire.

2. Have all EMPG funded personnel completed the additional required FEMA trainings?*

Yes

G191, IS2200 and IS/K2300.
Required completion within 24 months of hire.

If answered 'No' on either training requirements questions, provide your plan to achieve training compliance in the section below.

Outline plan to meet training requirements.

Baseline #5- Exercise Requirements

The Severe Weather Drill and the Great Shake Out Drill will no longer be considered allowable EMPG exercises for this requirement.

1. I understand all EMPG funded personnel must participate in no less than two (2) exercises per calendar year with one exercise being Operations based.*

Yes

Baseline Requirement #6- Integrated Preparedness Planning Workshop (IPPW)

I understand that all EMPG sub-recipients are required to conduct or participate in an annual Integrated Preparedness Planning Workshop (IPPW).*

Yes

At a minimum EMPG sub-recipients should maintain a local IPP that addresses the jurisdiction's compliance with EMPG training and exercise requirements.

Baseline Requirement #7- WebEOC

I understand that my awarded agency will be required to utilize WebEOC during incidents, events and related WebEOC trainings.* Yes

Baseline Requirement #8- THIRA

Threat and Hazard Identification and Risk Assessments (THIRA)

I understand that all EMPG sub-recipients are required to participate in the development or maintenance of state or regional THIRA at a minimum of at least once every three (3) years.*

Yes

Participation in THIRA development may include serving as a member of regional working groups, interacting with state or regional THIRA planners, and/or answering THIRA data call queries.

This Form Completed By:

* Phil Amtower 417-582-5400
 Name Title Phone
 * philamtower@christiancountymo.gov 06/07/2023
 E-mail Date Completed

Capitalization Level

Enter your agency's capitalization level. This is the dollar amount which qualifying expenditures are recorded as fixed assets for your City/County.

Capitalization Level:* \$1,000.00

Personnel

Line Item Code:	Name:	Position Title:	Position Status:	Employment Status:	Total Annual Salary:	% of Grant Funded Time:	Total Salary Cost:	Federal Amount:	Match Portion Provided:
1001	Phil Amtower	Director	Existing	Full Time	\$60,505.12	100.0	\$60,505.12	\$30,252.56	\$30,252.56
1002	Vacant / Open	Assistant Director	Existing	Full Time	\$42,000.00	100.0	\$42,000.00	\$21,000.00	\$21,000.00
1003	Cheryl Mitchell	Administrative Assistant	Existing	Full Time	\$39,124.80	100.0	\$39,124.80	\$19,562.40	\$19,562.40
								\$70,814.96	\$70,814.96

Personnel Justification

For each position, provide narrative justification.

If you request a new position or an increase for a current position, please explain why it is being requested. How has the agency paid for this expense in the past?

Increased salaries for Director and Admin Assistant as of 01/01/2023

Director, Phil Amtower: This position is responsible for directing, organizing, supervising, and coordinating the mitigation, protection, preparedness, response, and recovery efforts for Christian County.

Assistant Director (vacant at present, soon to be filled): This position assists with coordination of daily emergency management functions for the department including maintaining the EOC in a state of readiness for response and recovery efforts and representation of the Emergency Management Department at meetings, organizational functions or civic engagements as assigned by the Director. In the Director's absence, is responsible for the activation of emergency plans in accordance with established policy and is on a 24-hour call. Provides direct backup for the Emergency Management Director during vacation weeks or Holidays. This position is responsible for 24x7 on-call emergency support services to assist with preparedness, response, and recovery efforts when activated or assigned by the Director.

Administrator Assistant, Cheryl Mitchell: With general supervision, provides administrative support for department, including customer service, accounting, purchasing, and record keeping inside the office and outside in the field. Ensures compliance with transparency legislation and provides information to the public. Position requires highly responsible individual with high level of attention to detail and ability to employ discretion and independent judgment.

5000 character limit

Personnel Benefits

Line Item Code:	Name:	Indicate the % of total benefits:	Total Benefits:	Federal Portion:	Match Portion Provided:
				\$0.00	\$0.00

Personnel Benefits Justification

If personnel benefits are included in the budget, provide percentage breakdown by position for each fringe benefit.

5000 Character Limit

Emergency Operation Center Supplies & Operating Expenses

Line Item Code:	Supply/Operation Type:	Item Name:	Quantity:	Unit Cost:	Total Supply and Operation Cost:	Federal Portion:	Match Portion Provided:
11001	Phone	MiFi, Cell Phones, Landlines & Internet	1.0	\$5,750.00	\$5,750.00	\$2,875.00	\$2,875.00
11002	EOC Maintenance (copier, computer, generator, etc.)	Xerox	1.0	\$800.00	\$800.00	\$400.00	\$400.00
11003	General Office Supplies (paper, pens, paper clips, etc.)	General Office	1.0	\$2,000.00	\$2,000.00	\$1,000.00	\$1,000.00
11004	Vehicle Maintenance (EM vehicles only)	Vehicle Maintenance	1.0	\$1,000.00	\$1,000.00	\$500.00	\$500.00
11005	Other (Computer, projector, chair, etc.)	EMA Storage fee	1.0	\$1,560.00	\$1,560.00	\$780.00	\$780.00
11006	Other (Computer, projector, chair, etc.)	Orion Software	1.0	\$1,000.00	\$1,000.00	\$500.00	\$500.00
						\$6,055.00	\$6,055.00

Emergency Operations Center Supplies & Operating Expenses Justification

If supplies or operating expenses are included in the budget, provide justification for each expense. Address why the item is necessary for the proposed project, who will use it, and how it will be used.

Each of the below line items listed in the Operations type, is vital to effectively operate the Christian County EMA office and serve Christian County Residents. These supplies will be utilized by the Christian County EMA staff.

Phone- All phone activities will assist with: regular office phone services, cell phones for Director and Assistant Director, office internet, conference calls/webinars, zoom meetings voice lines, alert notification system, and wireless MiFi's, which are utilized by EMA personnel.

EOC Maintenance- This Operation type is mainly used to assist in the monthly fees for the contract and copies on the main EMA office copier. In addition, may be utilized for maintenance of other EOC office equipment.

General office Supplies- This operation type is utilized to purchase need EMA office supplies such as but not limited to: Printer paper, basic office supplies, printer cartridges, organizing aids, desk accessories, etc. Purchased through various vendors and utilized by EMA personnel.

Vehicle maintenance- This Operation type is a vital function to assist in keeping our EM vehicles in working condition. This operation may cover but not limited to: EM vehicle repairs, oil changes, tires and etc.

Other- This Operation type is valuable to assist in the expenses of CC EMA's yearly storage fee. This storage unit stores CC EMA equipment and supplies.

Other- This operation type is used to assist in the Orion Software yearly fee. To ensure disaster damage assessment is properly documented during a disaster.

Emergency Operation Center Office Equipment

Line Item Code:	Item Name:	AEL Category:	Qty:	Unit Cost:	Total Office Equipment Costs:	Federal Portion:	Match Portion Provided:
	Desktop Computer	Information Technology (Category 4)	1.0	\$1,300.00	\$1,300.00	\$650.00	\$650.00
						\$650.00	\$650.00

Emergency Operations Center Office Equipment Justification

If equipment is included in the budget, provide justification for each expense. Address why the item is necessary for the proposed project, who will use it, and how it will be used.

Directors desktop is beyond it's useful life. Needed upgrade to keep compliant with current Cyber Security issues, increased storage space and increased RAM to deal with today's software requiring more memory and processing speed.

Used by the Director for everyday computing needs. Email, word processing, ARC GIS, internet, etc.

5000 Character Limit

Travel

Line Item Code:	Item Name:	Category:	Explanation of Other Travel:	Total Cost:	Federal Portion:	Match Portion Provided:
					\$0.00	\$0.00

Travel Justification

If travel is included in the budget, provide justification for each expense. Explain why it is necessary to the success of the proposed project. Include: schedule of travel, duration, location and frequency.

For conferences, identify the location, date(s), and attendee(s) of the conference.

5000 Character Limit

Total Budget

Personnel	\$70,814.96	\$70,814.96	\$141,629.92
	Federal	Match	Total

Benefits	\$0.00	\$0.00	\$0.00
	Federal	Match	Total
Supplies	\$6,055.00	\$6,055.00	\$12,110.00
	Federal	Match	Total
Office Equip	\$650.00	\$650.00	\$1,300.00
	Federal	Match	Total
Travel	\$0.00	\$0.00	\$0.00
	Federal	Match	Total
Total	\$77,519.96	\$77,519.96	\$155,039.92
	Federal	Match	Total

Certification of Local Match

Type of Match:	Source Name	Match Amount
Hard	General Fund	\$70,814.96
		\$70,814.96

Supplanting

I, as my agency's Authorized Official certify that any funds awarded through the Emergency Management Performance Grant (EMPG) shall be used to supplement existing funds for program activities and will not replace (supplant) non-federal funds that have been appropriated for the purposes and goals of the grant.

Select box to certify understanding:* Yes

Authorized Official Title:* Christian County Presiding Commissioner

Authorized Official Name:* Lynn Morris

Authorized Official Phone #:* 417-582-5400

Authorized Official Email:* lmorris@christiancountymo.gov

Date Certified:* 06/07/2023

Audit Details

Date last audit completed: 06/01/2022
MM/DD/YYYY*

Dates covered by last audit: 01/01/2021 -1/31/2021
MM/DD/YYYY-
MM/DD/YYYY*

Last audit performed by:* KPM

Phone number of auditor* 417-882-4300

Date of next audit: 07/01/2023
MM/DD/YYYY*

Dates to be covered by next audit: 01/01/2022 - 12/31/2022
MM/DD/YYYY-
MM/DD/YYYY*

Next audit will be performed by:* KPM

Audit Certification

We have exceeded the federal expenditure threshold of \$750,000 in federal funds during agency's last fiscal year. We will have our Single Audit or Program Specific Audit completed and will submit the audit report within nine (9) months after the end of the audited fiscal year.

Threshold Exceeded?* No

Certified By:

* Amy Dent Christian County Auditor
First Name Last Name Title

* 100 W. Elm Room 100
Address

* Ozark Missouri 65721
City State Zip Code

* 417-528-4368 adent@christiancountymo.gov 06/01/2021
Telephone Ext. Cell Phone E-mail Address Date

Certified Application Assurance

To the best of my knowledge and belief, all data in this application is correct and the document has been duly authorized by the governing body of the agency. As the applicant agency, we attest to and will comply with the requirements of the 2021 Emergency Management Performance Grant.

I have read and am familiar with the following documents:

- 2021 EMPG Program Manual
- 2021 EMPG Notice of Funding Opportunity

I have provided copies of these documents to the Authorized Official and Project Director.

Your typed name as the applicant represents your acceptance of the requirements of this application.

Name:* Phil Amtower
Job Title:* EMD
Date:* 06/07/2023

Required Attachments

Attachment	Description	File Name	Type	File Size
NIMS Ordinance or Resolution				
Audit	CC Audit 2021	Christian-County-FINAL-2021.pdf	pdf	709 KB

Inventory	2023 CC Inventory	2023ChristianCountyInventory.xls	xls	44 KB
Employment Contract				
Benefit Rate Sheets				

Other Attachments



Christian County Commission

100 W. Church Street Room 100
Ozark, Missouri 65721
(417)582-4300

Lynn Morris
Presiding Commissioner

Bradley A. Jackson
Eastern Commissioner

Hosea Bilyeu
Western Commissioner

June 13, 2023

Summit Mailing
500 Enterprise Drive
Edmond, OK 736013-3670
405-509-6526
mattp@summitokc.com

Re: Award of Postage Meter Equipment

The Christian County Commission voted in session today to award the IMI-compliant Quadiant postage meter(s) equipment to Summit Mailing utilizing the State of Missouri contract #CC21938008.

Your point of contact will be Director of Resource Management, Todd Wiesehan. Mr. Wiesehan can be reached at 417-582-4386 or by email at: toddwiesehan@christiancountymo.gov.

We look forward to working with you.



Hosea Bilyeu
Western Commissioner

Date: 6-13-2023



Lynn Morris
Presiding Commissioner

Date: 6/13/23

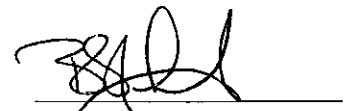

Bradley A. Jackson
Eastern Commissioner

Date: 6-13-23



Christian County Commission

100 W. Church Street Room 100
Ozark, Missouri 65721
(417)582-4300

Lynn Morris
Presiding Commissioner

Bradley A. Jackson
Eastern Commissioner

Hosea Bilyeu
Western Commissioner

June 13, 2023

Quadient
478 Wheelers Farm Road
Milford, CT 06461
417-464-0135
us.poadmin@quadient.com

Re: Award of Postage Funding Agreement

The Christian County Commission voted in session today to award the Postage Funding Agreement to Quadient, utilizing the State of Missouri contract #CC21938008.

Your point of contact will be Director of Resource Management, Todd Wiesehan. Mr. Wiesehan can be reached at 417-582-4386 or by email at: toddwiesehan@christiancountymo.gov.

We look forward to working with you.

Hosea Bilyeu

Western Commissioner

Date: 6-13-2023

Lynn Morris

Presiding Commissioner

Date: 6/13/23

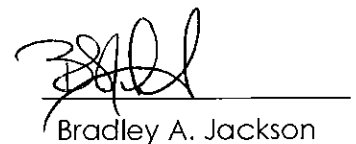
Bradley A. Jackson

Eastern Commissioner

Date: 6/13/23

MAILING EQUIPMENT, SUPPLIES AND MAINTENANCE

Led by the State of Arizona

Master Agreement #: **CTR058809**
Contractor: **QUADIENT, INC.**
Participating Entity: **STATE OF MISSOURI CC221938008**

This Participating Addendum is entered into by Contractor and Participating Entity (collectively, the "Parties").

Scope and Participation:

1. Scope:
 - This Participating Addendum includes the entire scope of the products and services available through the Master Agreement referenced above.

2. Participation: This Participating Addendum covers participation of Participating Entity in the above-referenced Master Agreement between the State of Arizona and Contractor for Mailing Equipment, Supplies and Maintenance. This Participating Addendum may be used by all state agencies, institutions of higher education, cities, counties, districts, and other political subdivisions of the state, and nonprofit organizations within the state if authorized herein and by law. Issues of interpretation and eligibility for participation are solely within the authority of the State Chief Procurement Official.

3. Term:
 - This Participating Addendum shall become effective as of the date of the last signature below and shall terminate upon the expiration or termination of the Master Agreement, as amended, unless the Participating Addendum is terminated sooner in accordance with the terms set forth herein.

Lead State amendments to extend the term date are automatically incorporated into this Participating Addendum unless terminated early in accordance with the terms and conditions of the Master Agreement or this Participating Addendum.

A Purchasing Entity may lease Products under this Participating Addendum by issuance of an Order. The Order shall survive the termination of this Participating Addendum and the Master Agreement.

4. Primary Contacts: The following (or their named successors) are the primary contact individuals for this Participating Addendum:



MAILING EQUIPMENT, SUPPLIES AND MAINTENANCE

Led by the State of Arizona

CONTRACTOR: Quadient, Inc.

Name:	Ryan Mikel, Manager Government Accounts
Address:	478 Wheelers Farms Rd., Milford, CT 06461
Telephone:	(281) 216-4596
Email:	r.mikel@quadient.com

PARTICIPATING ENTITY: STATE OF MISSOURI

Name:	Melissa Sackett
Address:	State of Missouri, Office of Administration, Division of Purchasing, 301 West High Street, Room 630, Jefferson City, MO 65101
Telephone:	(573) 526-2716
Fax:	(573) 526-9816
Email:	melissa.sackett@oa.mo.gov

Participating Entity Modifications and Additions to the Master Agreement

This Participating Addendum incorporates all terms and conditions of the Master Agreement as applied to the Participating Entity and Contractor.

Equipment lease agreement and meter rental agreements terms and conditions included in the Master Agreement and attached herein have been approved for use by the Participating State

MAILING EQUIPMENT, SUPPLIES AND MAINTENANCE

Led by the **State of Arizona**

Any limitations, modifications, or additions specified herein apply only to the agreement and relationship between Participating Entity and Contractor and shall not amend or affect other participating addendums or the Master Agreement itself.

The following changes are modifying or supplementing the Master Agreement terms and conditions.

- State of Missouri Contract Document CC221938008
 - For informational purposes, the contractor is requested to complete Attachment 1 of this Participating Addendum regarding their economic impact to the State of Missouri.
 - Software license terms and conditions shall be mutually agreed upon in writing by the purchasing entity's authorized individual and the contractor, on a case by case basis,
 - All purchasing entities requiring the use of postage meter will comply with all United State Postal Service regulations and meter terms and conditions applicable to the rental and use of postage meters supplied under this participating addendum as provided by the contractor.
5. Subcontractors: All contractors, dealers, and resellers authorized to provide sales and service support in Participating Entity's state, as shown on Contractor's NASPO ValuePoint-specific webpage, may provide sales and service support to users of this Participating Addendum. Participation of Contractor's contractors, dealers, and resellers will be in accordance with the terms and conditions set forth in the Master Agreement.
6. Orders: Any order placed by Participating Entity or a Purchasing Entity for a product or service offered through this Participating Addendum shall be deemed to be a sale under, and subject to the pricing and other terms and conditions of, the Master Agreement unless the parties to the order agree in writing that another contract or agreement applies to the order.
- All purchase orders issued by purchasing entities within the jurisdiction of this Addendum must include the following (1) Mandatory Language "PO is subject to NASPO Contract #CTR058809". (2) Your Name, Address, Contact, Phone Number, Signature and Participating State contract number CC221938008.





MAILING EQUIPMENT, SUPPLIES AND MAINTENANCE
Led by the State of Arizona

IN WITNESS WHEREOF, the Parties have executed this Participating Addendum.

PARTICIPATING ENTITY

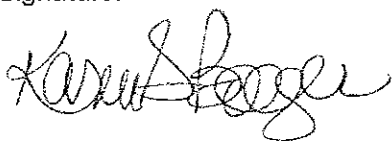
CONTRACTOR

Signature: 	Signature: 
Name: Karen Boeger	Name: John Tartaro
Title: Director of Division of Purchasing, State of Missouri	Title: Deputy, CFO
Date: 12-28-2022	Date: 11/8/2022

[Additional signatures may be added if required by the Participating Entity.]

For questions regarding NASPO ValuePoint Participating Addendums, please contact the Cooperative Contract Coordinator team at info@naspovaluepoint.org.

Fully executed NASPO ValuePoint Participating Addendums must be submitted via email in PDF format to pa@naspovaluepoint.org.



MAILING EQUIPMENT, SUPPLIES AND MAINTENANCE

Led by the State of Arizona

ATTACHMENT 1
MISSOURI ECONOMIC IMPACT

The utilization of Missouri businesses and Missouri employees and other positive economic impact in the provision of the products and/or services under the agreement between the State of Missouri and the vendor is highly desirable for the State of Missouri. Therefore, please provide responses to the following to describe your Missouri economic impact.

1. Provide a description of the company's economic presence within the State of Missouri, including Missouri employees statistics, Missouri business facilities (size, type of facility, location), Missouri subcontractors, etc.

Bowmans Mailing Solutions is one of our authorized dealers which is located at 410 Sovereign Ct. Suite 17, Manchester MO 63011. We currently have 6 employees living in Missouri.

2. Provide a description of the proposed services that will be performed and/or the proposed products that will be provided by the Missourians and/or Missouri products under Missouri Contract Number (CC221938008).

Quadient, Inc. delivers mailing, business communications management and shipping hardware and software solutions as well a full range of consultancy, maintenance and financing services. These have been specified under the NASPO Value Point catalog. Installation, training and on-site service will be provided by both our district office and local authorized dealers.

3. Provide a description of the economic impact returned to the State of Missouri through tax revenue obligations.

2021	Quadient, Inc.	Quadient leasing USA, Inc.
Sales Tax	\$ 44,245	\$ 177,071
Income Tax	Not yet filed	Not yet filed
Withholding Tax	\$ 23,775	

2020	Quadient, Inc.	Quadient leasing USA, Inc.
Sales Tax	\$ 42,393	\$ 186,119
Income Tax	0	0
Withholding Tax	\$ 22,597	



MAILING EQUIPMENT, SUPPLIES AND MAINTENANCE

Led by the State of Arizona

-
-
4. List all Missouri certified Minority Business Enterprises (MBE)/Women Business Enterprises (WBE) as defined at Website: <http://oeo.mo.gov> you will use in the provision of products and services under the contract:

_____none_____

5. List all Missouri Organizations for the Blind or any Missouri Sheltered Workshops as listed at Websites <http://dese.mo.gov/special-education/sheltered-workshops/directories>, <http://www.lhbindustries.com> and <http://www.alphapointe.org> you will use in the provision of products and services under the contract:

_____none_____

6. List all Missouri Service-Disabled Veteran Business Enterprises (SDVE's) as listed at Website <http://oa.mo.gov/purchasing/vendor-information/missouri-service-disabled-veteran-business-enterprise-sdve-information> you will use in the provision of products and services under the contract:

_____none_____



NOTICE OF AWARD

State Of Missouri
Office Of Administration
Division Of Purchasing
PO Box 809
Jefferson City, MO 65102-0809
<http://oa.mo.gov/purchasing>

SOLICITATION NUMBER CPPC30034902201938	CONTRACT TITLE Statewide – Mailing Equipment, Supplies, and Maintenance (NASPO)
CONTRACT NUMBER CC221938008	CONTRACT PERIOD January 1, 2023 through May 14, 2024
REQUISITION/REQUEST NUMBER N/A	MissouriBUYS SYSTEM ID MB00081792
CONTRACTOR NAME AND ADDRESS Quadient, Inc. 478 Wheelers Farms Rd. Milford, CT 06461	STATE AGENCY'S NAME AND ADDRESS Statewide Various Agency Locations throughout the State of Missouri
ACCEPTED BY THE STATE OF MISSOURI AS FOLLOWS: Contract CC221938008 is hereby established pursuant to Chapter 34.046 of the Revised Statutes of the State of Missouri. The contract consists of the attached documentation as specified on page 2 of the Cooperative Contract Procurement document dated 11/8/22, including the NASPO contract, #CTR058809, the State of Missouri Terms and Conditions, and the referenced Participating Addendum Master Agreement. All transactions and invoicing conducted under the Missouri contract must reference the official Missouri contract number, CC221938008. The attached document shall constitute the established contract.	
BUYER Melissa Sackett	BUYER CONTACT INFORMATION Email: melissa.sackett@oa.mo.gov Phone: (573) 526 - 2716 Fax: (573) 526-9816
SIGNATURE OF BUYER 	DATE 12/29/22
DIRECTOR OF PURCHASING Karen S. Boeger	



**STATE OF MISSOURI
OFFICE OF ADMINISTRATION
DIVISION OF PURCHASING (PURCHASING)
COOPERATIVE CONTRACT PROCUREMENT**

CONTRACT NO.: CC221938008
REQ NO.: N/A
TITLE: Statewide - Mailing Equipment, Supplies,
& Maintenance

BUYER: Melissa Sackett
PHONE NO.: (573) 526-2716
E-MAIL: melissa.sackett@oa.mo.gov

TO: Quadient, Inc.
478 Wheelers Farms Rd.
Milford, CT 06461

RETURN DOCUMENT TO THE DIVISION OF PURCHASING (PURCHASING) BY E-MAIL OR FAX:

SCAN AND E-MAIL TO:	melissa.sackett@oa.mo.gov
FAX TO:	(573) 526-9816

DELIVER SUPPLIES/SERVICES FOB (Free On Board) DESTINATION TO THE FOLLOWING ADDRESS:

**Statewide
Various Agency Locations throughout the State of Missouri**

The Contractor hereby agrees to provide the services and/or supplies described in the attached NASPO Contract #CTR058809 for the State of Missouri subject to the conditions stated on page 2. The Contractor further agrees that when a Notice of Award is signed and issued by an authorized official of the State of Missouri, a binding contract shall exist between the Contractor and the State of Missouri. The Contractor must be registered in MissouriBUYS. If not registered in MissouriBUYS, the Contractor must register in MissouriBUYS immediately upon request by the state.

SIGNATURE REQUIRED

VENDOR NAME Quadient, Inc.	MissouriBUYS SYSTEM ID (SEE VENDOR PROFILE - MAIN INFORMATION SCREEN)
MAILING ADDRESS 478 Wheelers Farms Rd.	
CITY, STATE, ZIP CODE Milford, CT 06461	
CONTACT PERSON Ryan Mikel, Government Account Manager	EMAIL ADDRESS r.mikel@quadient.com
PHONE NUMBER 615-592-1226	FAX NUMBER 203-301-2600
VENDOR TAX FILING TYPE WITH IRS (CHECK ONE) <input checked="" type="checkbox"/> Corporation <input type="checkbox"/> Individual <input type="checkbox"/> State/Local Government <input type="checkbox"/> Partnership <input type="checkbox"/> Sole Proprietor <input type="checkbox"/> IRS Tax-Exempt	
AUTHORIZED SIGNATURE 	DATE 11/8/2022
PRINTED NAME John Tartaro	TITLE Deputy, CFO

CONTRACT TITLE: MAILING EQUIPMENT, SUPPLIES & MAINTENANCE**CONTRACT PERIOD: DATE OF AWARD THROUGH MAY 14, 2024**

Contract CC221938008 is awarded by the State of Missouri consisting of the following:

- ❖ The Cooperative Contract Procurement including the attached State of Missouri Terms and Conditions (See Exhibit A).
- ❖ The attached NASPO ValuePoint/State of Arizona Master Agreement CTR058809, signed by the State of Arizona, Arizona Department of Administration State Procurement Office.
- ❖ The attached Participating Addendum.

The contractor shall provide mailing equipment, supplies, and maintenance to the State of Missouri, state agencies political subdivisions and/or governmental entities at the firm, fixed prices/discounts specified in the State of Arizona Offer and Acceptance/Master Agreement CTR058809 and Bid Solicitation BPM003137. All references to the State of Arizona in the attached documentation shall be deemed to refer to the State of Missouri with the exception of information specific to the State of Arizona such as background information, statistical/factual information, etc.

The contractor shall submit invoices for supplies provided for the State of Missouri to the ship to address shown on the purchase order.

The contractor shall understand and agree the following provisions are hereby modified as follows:

Cooperative Procurement Program:

The contractor shall participate in the State of Missouri's Cooperative Procurement Program. The contractor shall provide mailing equipment, supplies, and maintenance as described herein under the terms and conditions, requirements and specifications of the contract, including prices, to other government entities in accordance with the Technical Services Act (section 67.360, RSMo, which is available on the internet at: <http://www.moga.mo.gov/mostatutes/stathtml/06700003601.html>.) The contractor shall further understand and agree that participation by other governmental entities is discretionary on the part of that governmental entity and the State of Missouri bears no financial responsibility for any payments due the contractor by such governmental entities.

Termination:

The Division of Purchasing reserves the right to terminate the contract at any time, for the convenience of the State of Missouri, without penalty or recourse, by giving written notice to the contractor at least thirty (30) calendar days prior to the effective date of such termination. In the event of termination pursuant to this paragraph, all documents, data, reports, supplies, equipment, and accomplishments prepared, furnished or completed by the contractor pursuant to the terms of the contract shall, at the option of the Division of Purchasing, become the property of the State of Missouri. The contractor shall be entitled to receive compensation for services and/or supplies delivered to and accepted by the State of Missouri pursuant to the contract prior to the effective date of termination. Provided, however that any leases or rental agreements that were entered prior to any such Contract termination or expiration shall survive for their stated term and shall not terminate as a result of the termination or expiration of this Contract.

Contractor Liability:

The contractor shall be responsible for any and all tort or statutory liability to third-parties (including, but not limited to, the contractor's agents, employees, and subcontractors) arising out of the contractor's provision of any equipment or services under the contract. In addition, the contractor agrees to defend and indemnify the State of Missouri, its agencies, employees, and assignees from and against all such liability.

The contractor also agrees to indemnify, defend, and hold harmless the State of Missouri, its agencies, employees, and assignees from and against any and all tort or statutory liability arising out of the provision of any equipment or services

by any subcontractor or other person employed by or under the supervision of the contractor under the terms of the contract.

The contractor shall not be responsible for any injury or damage occurring solely as a result of any negligent act or omission by the State of Missouri, its agencies, employees, or assignees.

The contractor shall not be responsible for any of the following: (1) third party claims against the State of Missouri for losses or damages except as described above (2) consequential damages (including lost profits or savings), even if the contractor is informed of their possibility.

The contractor shall understand and agree that pursuant to the Constitution of the State of Missouri, Article III, Section 39 the state shall not indemnify, hold harmless, or agree in advance to defend any person or entity.

Insurance:

The contractor shall understand and agree that the State of Missouri cannot save and hold harmless and/or indemnify the contractor or employees against any liability incurred or arising as a result of any activity of the contractor or any activity of the contractor's employees related to the contractor's performance under the contract. Therefore, the contractor must acquire and maintain adequate liability insurance in the form(s) and amount(s) sufficient to protect the State of Missouri, its agencies, its employees, its clients, and the general public against any such loss, damage and/or expense related to his/her performance under the contract. General and other non-professional liability insurance shall include an endorsement that adds the State of Missouri as an additional insured. Self-insurance coverage or another alternative risk financing mechanism may be utilized provided that such coverage is verifiable and irrevocably reliable and the State of Missouri is protected as an additional insured. In the event any insurance coverage is canceled, the state agency must be notified at least thirty (30) calendar days prior to such cancellation.

Subcontractors:

Any subcontracts for the products/services described herein must include appropriate provisions and contractual obligations to ensure the successful fulfillment of all contractual obligations agreed to by the contractor and the State of Missouri and to ensure that the State of Missouri is indemnified, saved, and held harmless from and against any and all claims of damage, loss, and cost (including attorney fees) of any kind related to a subcontract in those matters described in the contract between the State of Missouri and the contractor.

The contractor shall expressly understand and agree that he/she shall assume and be solely responsible for all legal and financial responsibilities related to the execution of a subcontract.

The contractor shall agree and understand that utilization of a subcontractor to provide any of the products/services in the contract shall in no way relieve the contractor of the responsibility for providing the products/services as described and set forth herein.

The contractor must obtain the approval of the State of Missouri prior to establishing any new subcontracting arrangements and before changing any subcontractors. The approval shall not be arbitrarily withheld.

Authorized Personnel:

The contractor shall only employ personnel authorized to work in the United States in accordance with applicable federal and state laws. This includes but is not limited to the Illegal Immigration Reform and Immigrant Responsibility Act (IIRIRA) and INA Section 274A.

If the contractor is found to be in violation of this requirement or the applicable state, federal, and local laws and regulations, and if the State of Missouri has reasonable cause to believe that the contractor has knowingly employed individuals who are not eligible to work in the United States, the state shall have the right to cancel the contract immediately without penalty or recourse and suspend or debar the contractor from doing business with the state.

The contractor shall agree to fully cooperate with any audit or investigation from federal, state, or local law enforcement agencies.

If the contractor meets the definition of a business entity as defined in section 285.525, RSMo, pertaining to section 285.530, RSMo, the contractor shall maintain enrollment and participation in the E-Verify federal work authorization program with respect to the employees hired after enrollment in the program who are proposed to work in connection with the contracted services included herein. If the contractor's business status changes during the life of the contract to become a business entity as defined in section 285.525, RSMo, pertaining to section 285.530, RSMo, then the contractor shall, prior to the performance of any services as a business entity under the contract:

- Enroll and participate in the E-Verify federal work authorization program with respect to the employees hired after enrollment in the program who are proposed to work in connection with the services required herein; AND
- Provide to the Division of Purchasing the documentation required in the exhibit titled, Business Entity Certification, Enrollment Documentation, and Affidavit of Work Authorization affirming said company's/individual's enrollment and participation in the E-Verify federal work authorization program; AND
- Submit to the Division of Purchasing a completed, notarized Affidavit of Work Authorization provided in the exhibit titled, Business Entity Certification, Enrollment Documentation, and Affidavit of Work Authorization.

In accordance with subsection 2 of section 285.530, RSMo, the contractor should renew their Affidavit of Work Authorization annually. A valid Affidavit of Work Authorization is necessary to award any new contracts.

Affidavit of Work Authorization and Documentation:

Affidavit of Work Authorization and Documentation - Pursuant to section 285.530, RSMo, if the vendor meets the section 285.525, RSMo, definition of a "business entity" (<https://revisor.mo.gov/main/OneSection.aspx?section=285.525>), the vendor must affirm the vendor's enrollment and participation in the E-Verify federal work authorization program with respect to the employees hired after enrollment in the program who are proposed to work in connection with the services requested herein. The vendor should complete applicable portions of **Exhibit A**, Business Entity Certification, Enrollment Documentation, and Affidavit of Work Authorization. The applicable portions of **Exhibit A** must be submitted prior to an award of a contract.

Federal Funds Requirement:

The contractor shall understand and agree that this procurement may involve the expenditure of federal funds. Therefore, in accordance with the Departments of Labor, Health and Human Services, and Education and Related Agencies Appropriations Act, Public Law 101-166, Section 511, "Steven's Amendment", the contractor shall not issue any statements, press releases, and other documents describing projects or programs funded in whole or in part with Federal funds unless the prior approval of the state agency is obtained and unless they clearly state the following as provided by the state agency:

- 1) the percentage of the total costs of the program or project which will be financed with Federal funds;
- 2) the dollar amount of Federal funds for the project or program; and
- 3) percentage and dollar amount of the total costs of the project or program that will be financed by nongovernmental sources.

Debarment Certification:

The contractor certifies by signing the signature page of this original document and any addendum signature page(s) that the contractor is not presently debarred, suspended, proposed for debarment, declared ineligible, voluntarily excluded from participation, or otherwise excluded from or ineligible for participation under federal assistance programs. The contractor should complete and return the attached certification regarding debarment, etc., **Exhibit B**. This document must be satisfactorily completed prior to award of the contract.

Future Notice:

Contractor acknowledges that any continuing obligation to notify the State of Missouri that awarded Contractor's Master Agreement of changes affecting the Master Agreement (including, by way of example only, notices required under any price change provisions of the Master Agreement) imposes a corresponding continuing obligation to notify the State of Missouri under this contract.

Contractor agrees to notify the State of Missouri within 30 days of all changes in the status of or amendment to the Master Agreement.

Contractor shall promptly notify the State of Missouri of any modifications to the Master Agreement, the State of Missouri will consider contractor's violation of this clause a material breach of the contract and the State of Missouri may immediately terminate this contract or pursue any other available contract remedy.

Delivery Performance:

The contractor and/or the contractor's subcontractor(s) shall deliver products in accordance with the contracted delivery times stated herein to the state agency upon receipt of an authorized purchase order or P-card transaction notice. Delivery shall include unloading shipments at the state agency's dock or other designated unloading site as requested by the state agency. All orders must be shipped *F.O.B. Destination, Freight Prepaid and Allowed*. All orders received on the last day of the contract, must be shipped at the contract price. All deliveries must be coordinated with the state agency.

Anti-Discrimination Against Israel Act Contractor Requirements:

If the contractor meets the definition of a company as defined in section 34.600, RSMo, and has ten or more employees, the contractor shall not engage in a boycott of goods or services from the State of Israel; from companies doing business in or with Israel or authorized by, licensed by, or organized under the laws of the State of Israel; or from persons or entities doing business in the State of Israel as defined in section 34.600, RSMo.

If the contractor meets the definition of a company as defined in section 34.600, RSMo, and the company's employees increases to ten or more during the life of the contract, then the contractor shall submit to the Division of Purchasing a completed Box C of the exhibit titled, Anti-Discrimination Against Israel Act Certification, and shall comply with the requirements of Box C.

If during the life of the contract, the contractor's business status changes to become a company as defined in section 34.600, RSMo, and the company has ten or more employees, then the contractor shall comply with, complete, and submit to the Division of Purchasing a completed Box C of the exhibit titled, Anti-Discrimination Against Israel Act Certification.

Anti-Discrimination Against Israel Act Certification Exhibit:

Regardless of company status or number of employees, contractor is requested to complete and submit the applicable portion of **Exhibit C - Anti-Discrimination Against Israel Act Certification** with their response. Pursuant to section 34.600, RSMo, if the contractor meets the section 34.600, RSMo, definition of a "company" (<https://revisor.mo.gov/main/OneSection.aspx?section=34.600>) and the vendor has ten or more employees, the contractor must certify in writing that the contractor is not currently engaged in a boycott of goods or services from the State of Israel as defined in section 34.600, RSMo, and shall not engage in a boycott of goods or services from the State of Israel, if awarded a contract, for the duration of the contract. The applicable portion of the exhibit must be submitted prior to an award of a contract.

Missouri Statewide Contract Quarterly Administrative Fee:

The contractor shall pay a one percent (1%) administrative fee to the State of Missouri which shall apply to all payments received by the contractor for all products provided under the contract. Payment of the one percent administrative fee shall be non-negotiable.

The contractor shall pay the administrative fee at the end of each calendar quarter (i.e. March 31, June 30, September 30, December 31). The total administrative fee for a given quarter must equal one percent (1%) of the total payments (minus returns and credits) received by the contractor during the calendar quarter as reported on the contractor's Missouri Statewide Contract Quarterly Administrative Fee Report specified below. The administrative fee must be received by the Division of Purchasing (Purchasing) no later than the 15th calendar day of the month immediately following the end of the calendar quarter, unless the 15th is not a business day in which case the next business day thereafter shall be considered the administrative fee deadline.

Payments shall be made using one of the following acceptable payment methods:

- **Check:** Personal check, company check, cashier's check, or money order made payable to the "Missouri Revolving Information Technology Trust Fund" and sent to the following mailing address: Division of Purchasing, P.O. Box 809, Jefferson City, MO 65102 – 0809 OR Division of Purchasing, 301 West High Street, Room 630, Jefferson City, MO 65101-1517. The contractor's payment by check shall authorize the State of Missouri to process the check electronically. The contractor understands and agrees that any returned check from the contractor may be presented again electronically and may be subject to additional actions and/or handling fees.
- **Electronic Payment:** Instructions on how to submit payments electronically by automated clearing house (ACH) will be provided upon request by contacting the Division of Purchasing at (573) 751-2387.

All payments of the administrative fee shall include the contract number on any check or transmittal document. However, only one contract number must be entered on a check or transmittal document. If submitting an administrative fee payment for more than one contract, then a separate check or electronic payment and associated transmittal document must be submitted by the contractor for each contract.

Missouri Statewide Contract Quarterly Administrative Fee Report:

The contractor shall submit a Missouri Statewide Contract Quarterly Administrative Fee Report to the Division of Purchasing which shall identify the total payments (minus returns and credits) received by the contractor from state agencies universities, and governmental entities in other states that were made pursuant to the contract.

The contractor shall prepare and submit the Missouri Statewide Contract Quarterly Administrative Fee Report at the end of each calendar quarter (i.e. March 31, June 30, September 30, December 31) for total payments (minus returns and credits) received by the contractor during the calendar quarter. The Missouri Statewide Contract Quarterly Administrative Fee Report must be received by the Division of Purchasing (Purchasing) no later than the 15th calendar day of the month following the reporting quarter entered on the report, unless the 15th is not a business day in which case the next business day thereafter shall be considered the reporting deadline. Even if there has been no usage of the contract during the reporting quarter, the contractor must still submit a report and indicate no payments were received by marking the appropriate box on the report form.

The Missouri Statewide Contract Quarterly Administrative Fee Report form may be downloaded from the following Purchasing website: <http://oa.mo.gov/purchasing/vendor-information>. The Missouri Statewide Contract Quarterly Administrative Fee Report is also included herein as **Attachment 1**. The Missouri Statewide Contract Quarterly Administrative Fee Report must be submitted using one of the following methods:

- **Mail:** Division of Purchasing,
P.O. Box 809, Jefferson City MO 65102-0809

OR

Division of Purchasing,
301 West High Street, Room 630, Jefferson City, MO 65101-1517

- **Fax:** (573) 526-9815

- **Email:** ereports@oa.mo.gov

The contractor shall agree that the Division of Purchasing reserves the right to modify the requested format and content of the Missouri Statewide Contract Quarterly Administrative Fee Report by providing thirty (30) calendar days written notice to the contractor. The contractor shall also agree the Division of Purchasing may unilaterally amend the contract, with thirty (30) calendar days notice to the contractor to change the method of payment of the administrative fee, the timing for submission of the Missouri Statewide Contract Quarterly Administrative Fee Report, and/or timing for payment of the administrative fee. The contractor shall understand and agree that if such an amendment is issued by the Division of Purchasing, the contractor shall comply with all contractual terms, as amended.

Missouri Statewide Contract Quarterly Usage Report:

The contractor shall submit a Missouri Statewide Contract Quarterly Usage Report to the Division of Purchasing (Purchasing) which shall provide the Data Element information listed below:

Data Element	Description
Contractor Name	Contractor name as it appears on the contract.
Statewide Contract Number	Statewide contract number as listed on the cover page of your contract with the State of Missouri.
Report Contact Name	Name of the person completing the report on behalf of the contractor.
Contact Phone Number	Phone number for the person completing the report.
Contact Email Address	Email address for the person completing the report.
Date Report Submitted	Date the Missouri Statewide Contract Quarterly Usage Report is submitted to Purchasing.
Reporting Quarter	Quarter for which the contractor is reporting purchases on the contract.
Entity Type	Indicate the type of entity by entering "S" for Missouri state agency, "P" for Missouri political subdivision, "U" for Missouri university, or "O" for political subdivision or state entity from another state.
Customer Name	Customer's name. If the customer has multiple locations, please only use the main entity name.
Product or Service	Description of product or service purchased.
Purchase Authorization Number/Identifier	Purchase Authorization Number/Identifier supplied by customer to contractor. Enter PO or other authorization number/identifier. If procurement card used, enter "P-Card".
Contract Line Item	Line item number on the contract.
Quantity Delivered	Quantity (i.e. excluding returns) of products delivered. Enter a quantity of "1" for a service/project.
Unit Price Charged	Unit Price Charged (i.e. excluding credits) for the product or service purchased.
Extended Price	Quantity Delivered X Unit Price Charged.

The contractor shall prepare and submit the Missouri Statewide Contract Quarterly Usage Report at the end of each calendar quarter (i.e. March 31, June 30, September 30, December 31) for the purchases made under the contract during the calendar quarter. The Missouri Statewide Contract Quarterly Usage Report must be received by the Division of Purchasing no later than the 15th calendar day of the month following the reporting quarter entered on the Missouri Statewide Contract Quarterly Usage Report, unless the 15th is not a business day in which case the next business day thereafter shall be considered the reporting deadline. Even if there has been no usage of the contract during the reporting quarter, the contractor must still submit a report and indicate no purchases were made.

The contractor must submit a Missouri Statewide Contract Quarterly Usage Report electronically either utilizing the "Missouri Statewide Contract Quarterly Usage Report" worksheet included herein in **Attachment 2** which is downloadable from <http://oa.mo.gov/purchasing/vendor-information> or utilizing another format which is Excel-exportable. The contractor must submit the Missouri Statewide Contract Quarterly Usage Report to the following email address: ereports@oa.mo.gov.

The contractor shall agree that the Division of Purchasing reserves the right to modify the requested format and content of the Missouri Statewide Contract Quarterly Usage Report by providing thirty (30) calendar days' written notice to the contractor. The contractor shall also agree the Division of Purchasing may unilaterally amend the contract, with thirty (30) calendar days' notice to the contractor to change the timing for submission of the Missouri Statewide Contract Quarterly Usage Report. The contractor shall understand and agree that if such an amendment is issued by the Division of Purchasing, the contractor shall comply with all contractual terms, as amended.

Outside United States: If any products and/or services offered under this RFP are being manufactured or performed at sites outside the United States, the vendor **MUST** disclose such fact and provide details in the space below or on an attached page.

Are any of the vendor's proposed products and/or services being manufactured or performed at sites outside the United States?	Yes <input type="checkbox"/>	No <input checked="" type="checkbox"/>
If YES, do the proposed products/services satisfy the conditions described in section 4, subparagraphs 1, 2, 3, and 4 of Executive Order 04-09? (see the following web link: http://s1.sos.mo.gov/CMSImages/Library/Reference/Orders/2004/eo04_009.pdf)	Yes <input type="checkbox"/>	No <input type="checkbox"/>
If YES, mark the appropriate exemption below, and provide the requested details: <ol style="list-style-type: none"> 1. <input type="checkbox"/> Unique good or service. <ul style="list-style-type: none"> • EXPLAIN: _____ 2. <input type="checkbox"/> Foreign firm hired to market Missouri services/products to a foreign country. <ul style="list-style-type: none"> • Identify foreign country: _____ 3. <input type="checkbox"/> Economic cost factor exists <ul style="list-style-type: none"> • EXPLAIN: _____ 4. <input type="checkbox"/> Vendor/subcontractor maintains significant business presence in the United States and only performs trivial portion of contract work outside US. <ul style="list-style-type: none"> • Identify maximum percentage of the overall value of the contract, for any contract period, attributed to the value of the products and/or services being manufactured or performed at sites outside the United States: ___% • Specify what contract work would be performed outside the United States: 		

EXHIBIT A
BUSINESS ENTITY CERTIFICATION, ENROLLMENT DOCUMENTATION,
AND AFFIDAVIT OF WORK AUTHORIZATION

BUSINESS ENTITY CERTIFICATION:

The vendor must certify their current business status by completing either Box A or Box B or Box C on this Exhibit.

- BOX A:** To be completed by a non-business entity as defined below.
BOX B: To be completed by a business entity who has not yet completed and submitted documentation pertaining to the federal work authorization program as described at <http://www.uscis.gov/e-verify>.
BOX C: To be completed by a business entity who has current work authorization documentation on file with a Missouri state agency including Division of Purchasing.

Business entity, as defined in section 285.525, RSMo, pertaining to section 285.530, RSMo, is any person or group of persons performing or engaging in any activity, enterprise, profession, or occupation for gain, benefit, advantage, or livelihood. The term "business entity" shall include but not be limited to self-employed individuals, partnerships, corporations, contractors, and subcontractors. The term "business entity" shall include any business entity that possesses a business permit, license, or tax certificate issued by the state, any business entity that is exempt by law from obtaining such a business permit, and any business entity that is operating unlawfully without such a business permit. The term "business entity" shall not include a self-employed individual with no employees or entities utilizing the services of direct sellers as defined in subdivision (17) of subsection 12 of section 288.034, RSMo.

Note: Regarding governmental entities, business entity includes Missouri schools, Missouri universities, out of state agencies, out of state schools, out of state universities, and political subdivisions. A business entity does not include Missouri state agencies and federal government entities.

BOX A – CURRENTLY NOT A BUSINESS ENTITY

I certify that _____ (Company/Individual Name) **DOES NOT CURRENTLY MEET** the definition of a business entity, as defined in section 285.525, RSMo pertaining to section 285.530, RSMo as stated above, because: (check the applicable business status that applies below)

- I am a self-employed individual with no employees; **OR**
 - The company that I represent employs the services of direct sellers as defined in subdivision (17) of subsection 12 of section 288.034, RSMo.

I certify that I am not an alien unlawfully present in the United States and if _____ (Company/Individual Name) is awarded a contract for the services requested herein under _____ (CPPC Number) and if the business status changes during the life of the contract to become a business entity as defined in section 285.525, RSMo pertaining to section 285.530, RSMo then, prior to the performance of any services as a business entity, _____ (Company/Individual Name) agrees to complete Box B, comply with the requirements stated in Box B and provide the Division of Purchasing with all documentation required in Box B of this exhibit.

 Authorized Representative's Name (Please Print)

 Authorized Representative's Signature

 Company Name (if applicable)

 Date

EXHIBIT A, continued

(Complete the following if you DO NOT have the E-Verify documentation and a current Affidavit of Work Authorization already on file with the State of Missouri. If completing Box B, do not complete Box C.)

BOX B – CURRENT BUSINESS ENTITY STATUS

I certify that Quadient, Inc. (Business Entity Name) **MEETS** the definition of a business entity as defined in section 285.525, RSMo pertaining to section 285.530.

~~John Tartaro~~ Scott Pompano
 Authorized Business Entity Representative's Name
 (Please Print)

[Signature]
 Authorized Business Entity
 Representative's Signature

Quadient, Inc.
 Business Entity Name

9-21-2022
 Date

us.government.com
 E-Mail Address

As a business entity, the vendor must perform/provide each of the following. The vendor should check each to verify completion/submission of all of the following:

Enroll and participate in the E-Verify federal work authorization program (Website: <http://www.uscis.gov/e-verify>; Phone: 888-464-4218; Email: e-verify@dhs.gov) with respect to the employees hired after enrollment in the program who are proposed to work in connection with the services required herein;

AND

Provide documentation affirming said company's/individual's enrollment and participation in the E-Verify federal work authorization program. Documentation shall include EITHER the E-Verify Employment Eligibility Verification page listing the vendor's name and company ID OR a page from the E-Verify Memorandum of Understanding (MOU) listing the vendor's name and the MOU signature page completed and signed, at minimum, by the vendor and the Department of Homeland Security – Verification Division. If the signature page of the MOU lists the vendor's name and company ID, then no additional pages of the MOU must be submitted;

AND

Submit a completed, notarized Affidavit of Work Authorization provided on the next page of this Exhibit.

EXHIBIT A, continued

AFFIDAVIT OF WORK AUTHORIZATION:

The vendor who meets the section 285.525, RSMo, definition of a business entity must complete and return the following Affidavit of Work Authorization.

Comes now John Tartaro Scott Pomponio (Name of Business Entity Authorized Representative) as Deputy, CFO (Position/Title) first being duly sworn on my oath, affirm Quadient, Inc. (Business Entity Name) is enrolled and will continue to participate in the E-Verify federal work authorization program with respect to employees hired after enrollment in the program who are proposed to work in connection with the services related to contract(s) with the State of Missouri for the duration of the contract(s), if awarded in accordance with subsection 2 of section 285.530, RSMo. I also affirm that Quadient, Inc. (Business Entity Name) does not and will not knowingly employ a person who is an unauthorized alien in connection with the contracted services provided under the contract(s) for the duration of the contract(s), if awarded.

In Affirmation thereof, the facts stated above are true and correct. (The undersigned understands that false statements made in this filing are subject to the penalties provided under section 575.040, RSMo.)

<u></u> Authorized Representative's Signature	<u>John Tartaro Scott Pomponio</u> Printed Name
<u>Deputy, CFO</u> Title	<u>9.21.2022</u> Date
<u>us.government@quadient.com</u> E-Mail Address	<u>1607861</u> E-Verify Company ID Number

Subscribed and sworn to before me this 21 of September 2022, I am
(DAY) (MONTH, YEAR)
commissioned as a notary public within the County of New Haven, State of
(NAME OF COUNTY)
Connecticut, and my commission expires on 11/30/2026.
(NAME OF STATE) (DATE)

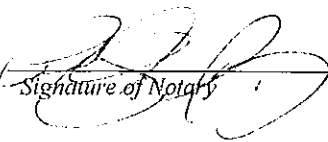
Signature of Notary
9/21/22
Date

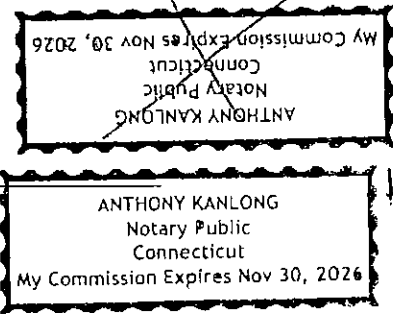

EXHIBIT A, continued

(Complete the following if you have the E-Verify documentation and a current Affidavit of Work Authorization already on file with the State of Missouri. If completing Box C, do not complete Box B.)

BOX C – AFFIDAVIT ON FILE - CURRENT BUSINESS ENTITY STATUS

I certify that Quadient, Inc. (Business Entity Name) **MEETS** the definition of a business entity as defined in section 285.525, RSMo pertaining to section 285.530, RSMo and have enrolled and currently participates in the E-Verify federal work authorization program with respect to the employees hired after enrollment in the program who are proposed to work in connection with the services related to contract(s) with the State of Missouri. We have previously provided documentation to a Missouri state agency that affirms enrollment and participation in the E-Verify federal work authorization program. The documentation that was previously provided included the following.

- ✓ The E-Verify Employment Eligibility Verification page OR a page from the E-Verify Memorandum of Understanding (MOU) listing the vendor's name and the MOU signature page completed and signed by the vendor and the Department of Homeland Security – Verification Division
- ✓ A current, notarized Affidavit of Work Authorization (must be completed, signed, and notarized within the past twelve months).

Name of Missouri State Agency to Which Previous E-Verify Documentation Submitted:
State of Missouri -Office of Administration -Division of Purchasing

Date of Previous E-Verify Documentation Submission: 10/17/2017

Previous Bid/Contract Number for Which Previous E-Verify Documentation Submitted: CC17501002
 _____ (if known)

Scott Pomponio
John Tartaro, Deputy CFO
 Authorized Business Entity Representative's Name
 (Please Print)

[Signature]
 Authorized Business Entity
 Representative's Signature

Quadient, Inc.
 Business Entity Name

9-21-2022
 Date

Us.government@quadient.com
 E-Mail Address

379156
 E-Verify MOU Company ID Number

FOR STATE OF MISSOURI USE ONLY

Documentation Verification Completed By:

 Buyer

 Date

EXHIBIT B
Certification Regarding
Debarment, Suspension, Ineligibility and Voluntary Exclusion
Lower Tier Covered Transactions

This certification is required by the regulations implementing Executive Order 12549, Debarment and Suspension, 29 CFR Part 98 Section 98.510, Participants' responsibilities. The regulations were published as Part VII of the May 26, 1988, Federal Register (pages 19160-19211).

(BEFORE COMPLETING CERTIFICATION, READ INSTRUCTIONS FOR CERTIFICATION)

- (1) The prospective recipient of Federal assistance funds certifies, by submission of this proposal, that neither it nor its principals are presently debarred, suspended, proposed for debarment, declared ineligible, or voluntarily excluded from participation in this transaction by any Federal department or agency.
- (2) Where the prospective recipient of Federal assistance funds is unable to certify to any of the statements in this certification, such prospective participant shall attach an explanation to this proposal.

Quadient, Inc.	080708241
Company Name	DUNS # (if known)
John Tartaro Scott Porcino	Deputy CFO
Authorized Representative's Printed Name	Authorized Representative's Title
	9-20-22 CFO
Authorized Representative's Signature	

Instructions for Certification

1. By signing and submitting this proposal, the prospective recipient of Federal assistance funds is providing the certification as set out below.
2. The certification in this clause is a material representation of fact upon which reliance was placed when this transaction was entered into. If it is later determined that the prospective recipient of Federal assistance funds knowingly rendered an erroneous certification, in addition to other remedies available to the Federal Government, the Department of Labor (DOL) may pursue available remedies, including suspension and/or debarment.
3. The prospective recipient of Federal assistance funds shall provide immediate written notice to the person to which this proposal is submitted if at any time the prospective recipient of Federal assistance funds learns that its certification was erroneous when submitted or has become erroneous by reason of changed circumstances.
4. The terms "covered transaction," "debarred," "suspended," "ineligible," "lower tier covered transaction," "participant," "person," "primary covered transaction," "principal," "proposal," and "voluntarily excluded," as used in this clause, have the meanings set out in the Definitions and Coverage sections of rules implementing Executive Order 12549. You may contact the person to which this proposal is submitted for assistance in obtaining a copy of those regulations.
5. The prospective recipient of Federal assistance funds agrees by submitting this proposal that, should the proposed covered transaction be entered into, it shall not knowingly enter into any lower tier covered transaction with a person who is debarred, suspended, declared ineligible, or voluntarily excluded from participation in this covered transaction, unless authorized by the DOL.
6. The prospective recipient of Federal assistance funds further agrees by submitting this proposal that it will include the clause titled "Certification Regarding Debarment, Suspension, Ineligibility and Voluntary Exclusion - Lower Tier Covered Transactions," without modification, in all lower tier covered transactions and in all solicitations for lower tier covered transactions.
7. A participant in a covered transaction may rely upon a certification of a prospective participant in a lower tier covered transaction that it is not debarred, suspended, ineligible, or voluntarily excluded from the covered transaction, unless it knows that the certification is erroneous. A participant may decide the method and frequency by which it determines the eligibility of its principals. Each participant may but is not required to check the List of Parties Excluded from Procurement or Nonprocurement Programs.
8. Nothing contained in the foregoing shall be construed to require establishment of a system of records in order to render in good faith the certification required by this clause. The knowledge and information of a participant is not required to exceed that which is normally possessed by a prudent person in the ordinary course of business dealings.
9. Except for transactions authorized under paragraph 5 of these instructions, if a participant in a covered transaction knowingly enters into a lower tier covered transaction with a person who is suspended, debarred, ineligible, or voluntarily excluded from participation in this transaction, in addition to other remedies available to the Federal Government, the DOL may pursue available remedies, including suspension and/or debarment.

EXHIBIT C
ANTI-DISCRIMINATION AGAINST ISRAEL ACT CERTIFICATION

Statutory Requirement: Section 34.600, RSMo, precludes entering into a contract with a company to acquire products and/or services “unless the contract includes a written certification that the company is not currently engaged in and shall not, for the duration of the contract, engage in a boycott of goods or services from the State of Israel; companies doing business in or with Israel or authorized by, licensed by, or organized under the laws of the State of Israel; or persons or entities doing business in the State of Israel.”

Exceptions: The statute provides two exceptions for this certification: 1) “contracts with a total potential value of less than one hundred thousand dollars” or 2) “contractors with fewer than ten employees.” Therefore, the following certification is required prior to any contract award.

Section 34.600, RSMo, defines the following terms:

Company - any for-profit or not-for-profit organization, association, corporation, partnership, joint venture, limited partnership, limited liability partnership, limited liability company, or other entity or business association, including all wholly-owned subsidiaries, majority-owned subsidiaries, parent companies, or affiliates of those entities or business associations.

Boycott Israel and Boycott of the State of Israel - engaging in refusals to deal, terminating business activities, or other actions to discriminate against, inflict economic harm, or otherwise limit commercial relations specifically with the State of Israel; companies doing business in or with Israel or authorized by, licensed by, or organized under the laws of the State of Israel; or persons or entities doing business in the State of Israel, that are all intended to support a boycott of the State of Israel. A company’s statement that it is participating in boycotts of the State of Israel; companies doing business in or with Israel or authorized by, licensed by, or organized under the laws of the State of Israel; or persons or entities doing business in the State of Israel, or that it has taken the boycott action at the request, in compliance with, or in furtherance of calls for a boycott of the State of Israel; companies doing business in or with Israel or authorized by, licensed by, or organized under the laws of the State of Israel; or persons or entities doing business in the State of Israel shall be considered to be conclusive evidence that a company is participating in a boycott of the State of Israel; companies doing business in or with Israel or authorized by, licensed by, or organized under the laws of the State of Israel; or persons or entities doing business in the State of Israel; provided, however that a company that has made no such statement may still be considered to be participating in a boycott of the State of Israel; companies doing business in or with Israel or authorized by, licensed by, or organized under the laws of the State of Israel; or persons or entities doing business in the State of Israel if other factors warrant such a conclusion.

Certification: The vendor must therefore certify their current status by completing either Box A, Box B, or Box C on the next page of this Exhibit.

- BOX A:** To be completed by any vendor that does not meet the definition of “company” above, hereinafter referred to as “Non-Company.”
- BOX B:** To be completed by a vendor that meets the definition of “Company” but has less than ten employees.
- BOX C:** To be completed by a vendor that meets the definition of “Company” and has ten or more employees.

EXHIBIT C, continued

BOX A – NON-COMPANY ENTITY

I certify that _____ (Entity Name) currently **DOES NOT MEET** the definition of a company as defined in section 34.600, RSMo, but that if awarded a contract and the entity’s business status changes during the life of the contract to become a “company” as defined in section 34.600, RSMo, and the entity has ten or more employees, then, prior to the delivery of any services and/or supplies as a company, the entity agrees to comply with, complete, and return Box C to the Division of Purchasing at that time.

Authorized Representative’s Name (Please Print)

Authorized Representative’s Signature

Entity Name

Date

BOX B – COMPANY ENTITY WITH LESS THAN TEN EMPLOYEES

I certify that _____ (Company Name) **MEETS** the definition of a company as defined in section 34.600, RSMo, and currently has less than ten employees but that if awarded a contract and if the company increases the number of employees to ten or more during the life of the contract, then said company shall comply with, complete, and return Box C to the Division of Purchasing at that time.

Authorized Representative’s Name (Please Print)

Authorized Representative’s Signature

Company Name

Date

BOX C – COMPANY ENTITY WITH TEN OR MORE EMPLOYEES

I certify that Quadient Inc (Company Name) **MEETS** the definition of a company as defined in section 34.600, RSMo, has ten or more employees, and is not currently engaged in a boycott of goods or services from the State of Israel; companies doing business in or with Israel or authorized by, licensed by, or organized under the laws of the State of Israel; or persons or entities doing business in the State of Israel as defined in section 34.600, RSMo. I further certify that if the company is awarded a contract for the services and/or supplies requested herein said company shall not engage in a boycott of goods or services from the State of Israel; companies doing business in or with Israel or authorized by, licensed by, or organized under the laws of the State of Israel; or persons or entities doing business in the State of Israel as defined in section 34.600, RSMo, for the duration of the contract.

John Tartaro

Scott Pompano

Authorized Representative’s Name (Please Print)

Authorized Representative’s Signature

Quadient, Inc.

Company Name

9-21-2022

Date

Company ID Number: 1607861

may subject the Web Services Employer, its subcontractors, its employees, or its representatives to: (1) prosecution for false statements pursuant to 18 U.S.C. 1001 and/or; (2) immediate termination of its MOU and/or; (3) possible debarment or suspension.

G. The foregoing constitutes the full agreement on this subject between DHS and the Web Services Employer.

Approved by:

Web Services Employer	
Quadient Inc	
Name (Please Type or Print)	Title
Patricia Steimle	
Signature	Date
Electronically Signed	11/13/2020
Department of Homeland Security – Verification Division	
Name (Please Type or Print)	Title
USCIS Verification Division	
Signature	Date
Electronically Signed	11/13/2020

MAILING EQUIPMENT, SUPPLIES AND MAINTENANCE

Led by the **State of Arizona**

Master Agreement #: **CTR058809**

Contractor: **QUADIENT, INC.**

Participating Entity: **STATE OF MISSOURI CC221938008**

This Participating Addendum is entered into by Contractor and Participating Entity (collectively, the "Parties").

Scope and Participation:

1. Scope:

This Participating Addendum includes the entire scope of the products and services available through the Master Agreement referenced above.

2. Participation: This Participating Addendum covers participation of Participating Entity in the above-referenced Master Agreement between the State of Arizona and Contractor for Mailing Equipment, Supplies and Maintenance. This Participating Addendum may be used by all state agencies, institutions of higher education, cities, counties, districts, and other political subdivisions of the state, and nonprofit organizations within the state if authorized herein and by law. Issues of interpretation and eligibility for participation are solely within the authority of the State Chief Procurement Official.

3. Term:

This Participating Addendum shall become effective as of the date of the last signature below and shall terminate upon the expiration or termination of the Master Agreement, as amended, unless the Participating Addendum is terminated sooner in accordance with the terms set forth herein.

Lead State amendments to extend the term date are automatically incorporated into this Participating Addendum unless terminated early in accordance with the terms and conditions of the Master Agreement or this Participating Addendum.

A Purchasing Entity may lease Products under this Participating Addendum by issuance of an Order. The Order shall survive the termination of this Participating Addendum and the Master Agreement.

4. Primary Contacts: The following (or their named successors) are the primary contact individuals for this Participating Addendum:



MAILING EQUIPMENT, SUPPLIES AND MAINTENANCE
Led by the **State of Arizona**

CONTRACTOR: Quadient, Inc.

Name:	Ryan Mikel, Manager Government Accounts
Address:	478 Wheelers Farms Rd., Milford, CT 06461
Telephone:	(281) 216-4596
Email:	r.mikel@quadient.com

PARTICIPATING ENTITY: STATE OF MISSOURI

Name:	Melissa Sackett
Address:	State of Missouri, Office of Administration, Division of Purchasing, 301 West High Street, Room 630, Jefferson City, MO 65101
Telephone:	(573) 526-2716
Fax:	(573) 526-9816
Email:	melissa.sackett@oa.mo.gov

Participating Entity Modifications and Additions to the Master Agreement

This Participating Addendum incorporates all terms and conditions of the Master Agreement as applied to the Participating Entity and Contractor.

Equipment lease agreement and meter rental agreements terms and conditions included in the Master Agreement and attached herein have been approved for use by the Participating State

MAILING EQUIPMENT, SUPPLIES AND MAINTENANCE

Led by the **State of Arizona**

Any limitations, modifications, or additions specified herein apply only to the agreement and relationship between Participating Entity and Contractor and shall not amend or affect other participating addendums or the Master Agreement itself.

The following changes are modifying or supplementing the Master Agreement terms and conditions.

- State of Missouri Contract Document CC221938008
 - For informational purposes, the contractor is requested to complete Attachment 1 of this Participating Addendum regarding their economic impact to the State of Missouri.
 - Software license terms and conditions shall be mutually agreed upon in writing by the purchasing entity's authorized individual and the contractor, on a case by case basis,
 - All purchasing entities requiring the use of postage meter will comply with all United State Postal Service regulations and meter terms and conditions applicable to the rental and use of postage meters supplied under this participating addendum as provided by the contractor.
5. Subcontractors: All contractors, dealers, and resellers authorized to provide sales and service support in Participating Entity's state, as shown on Contractor's NASPO ValuePoint-specific webpage, may provide sales and service support to users of this Participating Addendum. Participation of Contractor's contractors, dealers, and resellers will be in accordance with the terms and conditions set forth in the Master Agreement.
6. Orders: Any order placed by Participating Entity or a Purchasing Entity for a product or service offered through this Participating Addendum shall be deemed to be a sale under, and subject to the pricing and other terms and conditions of, the Master Agreement unless the parties to the order agree in writing that another contract or agreement applies to the order.

All purchase orders issued by purchasing entities within the jurisdiction of this Addendum must include the following (1) Mandatory Language "PO is subject to NASPO Contract #CTR058809". (2) Your Name, Address, Contact, Phone Number, Signature and Participating State contract number CC221938008.



MAILING EQUIPMENT, SUPPLIES AND MAINTENANCE
Led by the State of Arizona

IN WITNESS WHEREOF, the Parties have executed this Participating Addendum.

PARTICIPATING ENTITY

CONTRACTOR

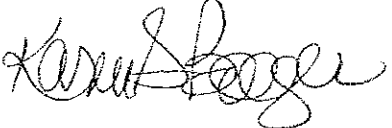
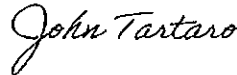
Signature: 	Signature: 
Name: Karen Boeger	Name: John Tartaro
Title: Director of Division of Purchasing, State of Missouri	Title: Deputy, CFO
Date: 12-28-2022	Date: 11/8/2022

[Additional signatures may be added if required by the Participating Entity.]

For questions regarding NASPO ValuePoint Participating Addendums, please contact the Cooperative Contract Coordinator team at info@naspovaluepoint.org.

Fully executed NASPO ValuePoint Participating Addendums must be submitted via email in PDF format to pa@naspovaluepoint.org.



MAILING EQUIPMENT, SUPPLIES AND MAINTENANCE

Led by the **State of Arizona**

ATTACHMENT 1
MISSOURI ECONOMIC IMPACT

The utilization of Missouri businesses and Missouri employees and other positive economic impact in the provision of the products and/or services under the agreement between the State of Missouri and the vendor is highly desirable for the State of Missouri. Therefore, please provide responses to the following to describe your Missouri economic impact.

1. Provide a description of the company's economic presence within the State of Missouri, including Missouri employees statistics, Missouri business facilities (size, type of facility, location), Missouri subcontractors, etc.

Bowmans Mailing Solutions is one of our authorized dealers which is located at 410 Sovereign Ct. Suite 17, Manchester MO 63011. We currently have 6 employees living in Missouri.

2. Provide a description of the proposed services that will be performed and/or the proposed products that will be provided by the Missourians and/or Missouri products under Missouri Contract Number (CC221938008).

Quadient, Inc. delivers mailing, business communications management and shipping hardware and software solutions as well a full range of consultancy, maintenance and financing services. These have been specified under the NASPO Value Point catalog. Installation, training and on-site service will be provided by both our district office and local authorized dealers.

3. Provide a description of the economic impact returned to the State of Missouri through tax revenue obligations.

2021	Quadient, Inc.	Quadient leasing USA, Inc.
Sales Tax	\$ 44,245	\$ 177,071
Income Tax	Not yet filed	Not yet filed
Withholding Tax	\$ 23,775	

2020	Quadient, Inc.	Quadient leasing USA, Inc.
Sales Tax	\$ 42,393	\$ 186,119
Income Tax	0	0
Withholding Tax	\$ 22,597	



MAILING EQUIPMENT, SUPPLIES AND MAINTENANCE

Led by the **State of Arizona**

-
-
4. List all Missouri certified Minority Business Enterprises (MBE)/Women Business Enterprises (WBE) as defined at Website: <http://oeo.mo.gov> you will use in the provision of products and services under the contract:

_____none_____

5. List all Missouri Organizations for the Blind or any Missouri Sheltered Workshops as listed at Websites <http://dese.mo.gov/special-education/sheltered-workshops/directories>, <http://www.lhbindustries.com> and <http://www.alphapointe.org> you will use in the provision of products and services under the contract:

_____none_____

6. List all Missouri Service-Disabled Veteran Business Enterprises (SDVE's) as listed at Website <http://oa.mo.gov/purchasing/vendor-information/missouri-service-disabled-veteran-business-enterprise-sdve-information> you will use in the provision of products and services under the contract:

_____none_____

GOVERNMENT PRODUCT LEASE AGREEMENT

In this Government Product Lease Agreement (the "Lease"), the words "You" and "Your" mean the lessee, which is the entity that is identified as the Customer on the Government Product Lease Agreement Order Form ("Order Form"). "We," "Us" and "Our" mean the lessor, Quadi^{ent} Leasing USA, Inc. "Supplier" refers to either Quadi^{ent}, Inc., or any other third party that has manufactured, or is providing services related to, the Products.

1. Lease of Products. THIS LEASE IS UNCONDITIONAL AND NON-CANCELABLE (except as provided in Section 24, below) during the Initial Term (as defined below). You agree to lease from Us the equipment, embedded software, Software, services and other products listed on the Order Form, together with all existing accessories, embedded software programs, attachments, replacements, updates, additions and repairs, (collectively the "Products") upon the terms stated herein. The term "Software" means any software that is subject to this Lease, other than software programs that are embedded in the hardware. Software is subject to the additional terms as may be provided by the Supplier.

2. Promise to Pay. You promise to pay to Us the lease payment shown on the Order Form ("Lease Payment") in accordance with the payment schedule set forth thereon, plus all other amounts stated in this Lease.

3. Initial Term; Renewal.

3.1 FMV Lease. The Initial Term of this Lease will begin on the date the Products are installed and will continue for the number of months shown on the applicable Order Form ("Initial Term"). Unless You have opted for an LTOP Lease as described in Section 23, You must notify Us in writing at least thirty (30) days before the end of the Initial Term that You intend to either: (i) return the Products at the end of the Initial Term; or (ii) purchase the Products pursuant to Section 22. If You have not opted for an LTOP lease and You fail to give us such notice, then this Lease will automatically renew for consecutive periods of one (1) month each (each a "Renewal Period"). The amount You pay for the Products will remain unchanged during each Renewal Period. We will not notify You that the Initial Term or any Renewal Period is ending. You may terminate this Lease at the conclusion of any Renewal Period by giving Us thirty (30) days prior written notice of Your intent to do so. If You notify Us in writing that You intend to terminate the Lease, as set forth above, You shall either return the Products pursuant to Section 12 of this Lease or purchase the products pursuant to Section 22.

3.2 LTOP Lease. If you have opted for an LTOP Lease as described in Section 23, then the term of this Lease will begin on the date the Products are installed and will continue for the number of months shown on the applicable Order Form ("Initial Term"). At the conclusion of the Initial Term of an LTOP Lease, we shall: (i) transfer title of all hardware Products to You as set forth in Section 23; and (ii) Your license to use any Software Products shall continue without the need to make any further license payments to Us.

4. Payments. Lease Payments, and other charges provided for herein, are payable in arrears periodically as stated on the Order Form.

You agree to make Lease Payments to Us at the address specified on Our invoices, or at any other place designated by Us within thirty (30) days of the date of Our invoice.

5. Delivery and Location of Products. The Products will be delivered to You at the installation address specified on the Order Form ("Installation Address") or, if no such location is specified, to Your billing address. Your acceptance of the Products occurs upon delivery of the Products. You shall not remove the Products from the Installation Address unless You first get Our written permission to do so.

6. Ownership, Use, and Maintenance of Products. We will own and have title to the Products during the Lease. You agree that the Products are and shall remain Our personal property. You authorize Us to record (and amend, if appropriate) a UCC financing statement to protect Our interests. You represent that the Products will be used solely for commercial purposes and not for personal, family or household purposes. At Your own cost, You agree to maintain the Products in accordance with the applicable operation manuals and to keep the Products in good working order, ordinary wear and tear excepted.

7. Assignment of Supplier's Warranties and Notice of Reused Components. We hereby assign to You any warranties relating to the Products that We may have received from the Supplier. GUIDED BY QUADI^{ENT}, INC.'S SUSTAINABLE DESIGN AND RESPONSIBLE MANUFACTURING POLICY, THE PRODUCTS MAY CONTAIN REUSED COMPONENTS. For more information visit <https://www.quadi^{ent}.com/about-us/sustainable-design-and-manufacturing>.

8. Relationship of the Parties. You agree that You, not We, selected the Products and the Supplier, and that We are a separate company from the Supplier and that the Supplier is not Our agent. IF YOU ARE A PARTY TO ANY MAINTENANCE, SERVICE, SOFTWARE LICENSE, SUPPLIES OR OTHER CONTRACT WITH ANY SUPPLIER, WE ARE NOT A PARTY THERETO, AND SUCH CONTRACT IS NOT PART OF THIS LEASE (EVEN THOUGH WE MAY, AS A CONVENIENCE TO YOU AND THE SUPPLIER, BILL AND COLLECT MONIES OWED BY YOU TO THEM).

9. Default. You will be in default under this Lease if You fail to pay any amount within ten (10) days of the due date or fail to perform or observe any other obligation in this Lease. If You default, We may, without notice to You, do any one or more of the following, at Our option, concurrently or separately: (A) cancel this Lease; (B) require You to return the Products pursuant to Section 12 below; (C) take possession of and/or render the Products unusable, and for such purposes You hereby authorize Us and Our designees to enter Your premises, with prior reasonable notice or other process of law; and (D) require You to pay to Us, on demand as liquidated damages and not as a penalty, an amount equal to the sum of: (i) all Lease Payments and other amounts then due and past due; (ii) all remaining Lease Payments for the then-current term, together with any taxes due or to become due during such term (which You agree is a reasonable estimate of Our damages); and (iii) in the event that You failed to promptly return the Products to Us, an amount equal to the remaining value of the Products at the end of the then-current term, as reasonably determined by Us. To the extent allowable by law, You shall also pay all Our costs in enforcing Our rights under this Lease,



including reasonable attorneys' fees and expenses that We incur to take possession, store, repair, or dispose of the Products, as well as any other expenses that We may incur to collect amounts owed to Us. We are not required to re-lease or sell the Products if We repossess them. These remedies shall be cumulative and not exclusive, and shall be in addition to any and all other remedies available to Us.

10. Finance Lease. You agree that this Lease is a "finance lease" as defined in Article 2A of the Uniform Commercial Code ("UCC"). To the extent permitted by law, You hereby waive any and all rights and remedies conferred upon You under UCC Sections 2A-303 and 2A-508 through 2A-522, or any similar laws.

11. Loss; Damage; Insurance. You shall: (i) bear the risk of loss and damage to the Product(s) during the Initial Term and any Renewal Period; and (ii) keep the Product(s) insured, at Your expense, against all risks of loss and damage in an amount at least equal to its full replacement cost.

12. Return of Products. Unless You take title to the tangible Products pursuant to Section 22 or Section 23, then You are required to return such Products under this Lease. In such a case, at the end of the Lease, You shall, after receiving an Equipment Return Authorization ("ERA") number from Us, promptly send the Products, at Your expense plus shipping and handling costs, to any location(s) that We designate in the contiguous United States. The Products must be properly packed for shipment with the ERA number clearly visible, freight prepaid and fully insured, and must be received in good condition, less normal wear and tear.

13. Assignment. YOU SHALL NOT SELL, TRANSFER, ASSIGN, SUBLEASE, PLEDGE OR OTHERWISE ENCUMBER (COLLECTIVELY, "TRANSFER") THE PRODUCTS OR THIS LEASE IN WHOLE OR IN PART.

14. Disclaimer of Warranties. WE MAKE NO REPRESENTATIONS OR WARRANTIES OF ANY KIND, EXPRESS OR IMPLIED, REGARDING ANY MATTER WHATSOEVER, INCLUDING, BUT NOT LIMITED TO, THE SUITABILITY OF THE PRODUCT(S), ITS CONDITION, ITS MERCHANTABILITY, ITS FITNESS FOR A PARTICULAR PURPOSE, ITS FREEDOM FROM INFRINGEMENT, OR OTHERWISE. WE PROVIDE THE PRODUCTS TO YOU "AS IS," "WHERE IS" AND "WITH ALL FAULTS."

15. Limitation of Liability. WE SHALL NOT BE LIABLE TO YOU AND YOU SHALL NOT MAKE A CLAIM AGAINST US FOR ANY LOSS, DAMAGE (INCLUDING INCIDENTAL, CONSEQUENTIAL OR PUNITIVE DAMAGES), OR EXPENSE OF ANY KIND ARISING DIRECTLY OR INDIRECTLY FROM THE DELIVERY, INSTALLATION, USE, RETURN, LOSS OF USE, DEFECT, MALFUNCTION, OR ANY OTHER MATTER RELATING TO THE PRODUCTS (COLLECTIVELY, "PRODUCT MATTERS"). NOTWITHSTANDING ANY OTHER PROVISION OF THIS LEASE, EXCEPT FOR DIRECT DAMAGES RESULTING FROM PERSONAL INJURY OR DAMAGE TO TANGIBLE PROPERTY CAUSED BY OUR GROSS NEGLIGENCE OR WILLFUL MISCONDUCT, THE MAXIMUM OUR LIABILITY TO YOU FOR DAMAGES HEREUNDER SHALL NOT EXCEED THE TOTAL OF THE AMOUNTS PAID TO US HEREUNDER BY YOU.

16. Notice. All notices, requests and other communications to Us shall be in writing and sent to: Quadiant Leasing USA, Inc., 478 Wheelers Farms Road, Milford, CT 06461 ("Notice Address"). Such notices shall be considered given when: (i) delivered personally, or (ii) sent by commercial overnight courier with written confirmation of delivery. In the event that We do not accept Your offer to enter this Lease, then You have the right to a written statement that specifies the reasons that Your offer was not accepted. You can request such a statement by writing to Us at the Notice Address.

17. Integration. The Lease represents the final and only agreement between You and Us. There are no unwritten oral agreements between You and Us. The Lease can be changed only by a written agreement between You and Us. Any additional terms and conditions referenced on any Purchase Order shall be void and have no effect on this Lease.

18. Severability. In the event any provision of this Lease shall be deemed to be invalid, illegal or unenforceable, the validity, legality and enforceability of the remaining provisions shall not in any way be affected or impaired thereby. The parties agree to replace any invalid provision with a valid provision, which most closely approximates the intent and economic effect of the invalid provision.

19. Waiver or Delay. A waiver of any default hereunder or of any term or condition of this Lease shall not be deemed to be a continuing waiver or a waiver of any other default or any other term or condition, but shall apply solely to the instance to which such waiver is directed. We may accept late payments, partial payments, checks, or money orders marked "payment in full," or with a similar notation, without compromising any rights under this Lease.

20. Survival of Obligations. Your obligations under this Lease shall survive any expiration or termination of any government procurement contract that may be related to it. Any obligations and duties which by their nature extend beyond the expiration or termination of this Lease shall survive the expiration or termination of this Lease.

21. Choice of Law; Venue; and Attorney's Fees. This Lease shall be governed under the laws of the State of Missouri.

22. FMV Leases. If this Lease is a fair market value lease, as indicated by the lease rate that has been used by Us to calculate Your Lease Payment then, unless You are in default, You may elect to purchase the hardware Products at the end of this Lease on an "as is, where is" basis for their fair market value, as reasonably determined by Us. In the event that You elect to do so, You must give us sixty (60) days prior written notice of Your election to purchase such Products.

23. LTOP Leases. If this Lease is a lease to purchase, as indicated



by the lease rate that has been used by Us to calculate Your Lease Payments then, at the end of the Initial Term and after You have made all of the Lease Payments, We shall transfer title to all hardware Products that are subject to this Lease to You on an "as is, where is" basis.

24. Termination.

24.1 Non-Appropriation.

a. You warrant and represent that You intend to enter into this Lease for at least the entire Initial Term and that You are doing so for an essential government purpose. You agree that, prior to the expiration of the Initial Term, you shall not terminate this Lease in order to obtain the same or similar Products from another vendor.

b. You may terminate this Lease at the end of Your current fiscal year, or at the end of any subsequent fiscal year, if appropriated funds are not available to You for the Lease Payments that will be due in the next fiscal year. In the event of such a non-appropriation, then You shall provide written notice to Us that states:

Sufficient funds have not been and will not be appropriated for the remaining payments due under the Lease. I confirm that we will not replace the Products with similar equipment from any other party in the succeeding fiscal year.

24.2 Convenience. You may terminate this Lease at any time and for any reason or for no reason ("Termination for Convenience"); provided that You comply with the provisions of this paragraph. In the event of a Termination for Convenience, You shall pay Us a termination charge equal to the net present value of the periodic payments remaining in the Initial Term or, if applicable, the then-current Renewal Term, discounted to the present value at an interest rate equal to six percent (6%) per annum. Such amount must be received by Us within thirty (30) days of the effective date of the termination.

25. Additional Postage Meter Terms. If the Products require a postage meter, then You agree that Quadient's Postage Meter Rental Agreement shall govern your rental of such postage meter.

POSTAGE METER RENTAL AGREEMENT

1. Incorporation of Certain Terms. Customer acknowledges that: (i) it has entered a Government Product Lease Agreement with Quadient Leasing USA, Inc. (the "Lease"); and (ii) if the Products that are subject to the Lease includes a mailing machine, then the terms of this Postage Meter Rental Agreement ("Rental Agreement") shall govern its rental of the Postage Meter (as defined below) for such machine. Any defined terms in the Lease shall have the same meanings in this Rental Agreement, except that "We," "Us," and "Our," refers to Quadient, Inc., and any reference to "Products" shall refer to the Postage Meter. Sections 11 through 21, 24 and 25 of the Lease are hereby incorporated into this Rental Agreement, except that any reference in those sections to the "Lease" refer to this Rental Agreement.

2. Provisions as to Use. You acknowledge that: (i) as required by United States Postal Service ("USPS") regulations, the postage meter(s) identified on the Order Form (the "Postage Meter") is being rented to You and that it is Our property; (ii) the Postage Meter will be surrendered by You upon demand by Us; (iii) You are responsible for the control and use of the Postage Meter; (iv) You will comply with all applicable laws regarding Your use or possession of the Postage Meter; (v) the use of the Postage Meter is subject to the conditions established from time to time by the United States Postal Service; and (vi) the Postage Meter is to be used only for generating an indicia to evidence the prepayment of postage and to account for postal funds. It is a violation of Federal law to misuse or tamper with the Postage Meter and, if You do so, We may terminate this Rental Agreement upon notice to You.

3. Rental Fee, Term, and Taxes. The rental fee for the Postage Meter rental during the Initial Term is included in the Lease Payment. For each Renewal Term, You agree to pay Our then-current fee for the Postage Meter rental. The Postage Meter rental fee does not include the cost of consumable supplies. The term of the rental shall be equal to the term of the Lease and is NON-CANCELABLE. You agree to pay all applicable taxes related to Your acquisition, possession, and/or use of the Postage Meter including all property taxes on the Postage Meter. Furthermore, You agree to pay the applicable fee to cover Our expenses associated with the administration, billing and tracking of such charges and taxes. Notwithstanding the foregoing, in the event You are tax exempt, upon providing Us a certificate, You will not be required to pay any taxes covered by such certificate. You agree that you will return the Postage Meter at the end of the Lease term and that You will do so in the manner set forth in Section 12 of the Lease. Furthermore, You agree that if you fail to return a postage meter within thirty (30) days of receipt of the Equipment Return Authorization from Us, then You will pay a postage meter replacement fee of one thousand dollars (\$1,000).

4. Postage Meter Maintenance, Inspections, and Location. We will keep the Postage Meter in good working condition during the term of this Rental Agreement. The United States Postal Service regulations may require Us to periodically inspect the Postage Meter. You agree to cooperate with Us regarding such inspections. We may, from time to time, access and download information from Your Postage Meter to provide Us with information about Your postage usage and We may share that information with Our distributors and other third parties and You hereby authorize Us to do so. You agree to promptly update Us whenever there is any change in Your name, address, telephone number, the licensing post office, or the location of the Postage Meter.

5. Postage Advances. We do not sell postage. In the event You require an emergency advance for postage, We, at Our sole discretion, may advance You money to reset the Postage Meter. If We do provide such an advance, You agree to repay Us within five (5) days from the time of such advance: (i) the amount of the emergency advance; and (ii) the then-current advance fee.

6. Default. In the event You fail to perform in accordance with the terms set forth in this Rental Agreement, or any other Agreement with Us or any of Our affiliates, including, but not limited to, Quadient Leasing USA Inc., and Quadient Finance USA, Inc., then We may, without notice: (i) repossess the Postage Meter(s); (ii) disable the Postage Meter; (iii) immediately terminate this Rental Agreement; and (iv) pursue any remedies available to Us at law or in equity.



Furthermore, upon the return of the Postage Meter, You hereby authorize Us to offset any amount of postage remaining in the Postage Meter, prior to any refund to You, against any amount due to Us or any of Our affiliates. To the extent allowable by law, You shall also pay all of Our costs in enforcing Our rights under this Rental Agreement, including reasonable attorneys' fees and expenses that We incur to take possession, store, or repair, the Postage Meter, as well as any other expenses that We may incur to collect amounts owed to Us. These remedies shall be cumulative and not exclusive, and shall be in addition to any and all other remedies available to Us.

7. Rate Updates.

- A. Maintenance of Postal Rates. It is Your sole responsibility to ensure that correct amounts are applied as payment for mailing and shipping services. We shall not be responsible for returns for delivery delays, refusals, or any other problems caused by applying the incorrect rate to mail or packages.
- B. Rate Updates with Online Services. If the Order Form indicates that You are enrolled in Our Online Services program, then We will make available periodic updates for Your covered Products and/or Postage Meter, including updates to maintain accurate USPS rates for the USPS services that are compatible with such Products or Postage Meter. **The rate updates that are offered with Our Online Services program are only available for products that are Integrated (as defined below) into Your mailing machine.** For the purposes of this section, "Integrated" means that the covered hardware cannot properly operate on a stand-alone basis and it has been incorporated into the mail machine. Products that are not Integrated including, but not limited to, all Software and scales with "ST-77," or "SE" in the model number will not receive updated rates as part of Our Online Services program (collectively "ExcludedProducts").
- C. Rate Updates with Rate Change Protection and Software Advantage. If You have any of Our Excluded Products, You may have elected to purchase Rate Change Protection ("RCP") from Us for Your hardware products or Software Advantage for Your Software. If the Order Form indicates that You have selected RCP or Software Advantage, We will make available the following updates for Your covered Products or Software: (i) updates to maintain accurate rates for the services offered by the USPS and other couriers that are compatible with Your covered Products or Software; and (ii) updates for major zip or zone changes that are compatible with Your covered Products or Software. If any reprogramming is required because You have moved the Products or Postage Meter to a new location, none of the services described in this Section cover the cost to do so. If You have not selected RCP or Software Advantage, You agree that We may send You periodic rate updates as needed and You agree to either: (i) promptly pay the then-current price for such update; or (ii) return the unused, update to Us within ten (10) business days of receiving it. Customers with an outstanding Accounts Receivable balance may not receive a rate update until the open balance is resolved.

8. United States Postal Service Acknowledgement of Deposit Requirement. By signing this Postage Meter Rental Agreement, You

acknowledge and agree that You have read the United States Postal Service Acknowledgement of Deposit (the "Acknowledgement") and will comply with its terms and conditions, as it may be amended from time to time.

9. Additional United States Postal Service Terms.

- A. By signing this Postage Meter Rental Agreement, You acknowledge that You are also entering into an Agreement with the United States Postal Service ("USPS") in accordance with the Domestic Mail Manual ("DMM") 604.4, Postage Payment Methods, Postage Meters and PC Postage Products (collectively, "Postage Evidencing Systems" or "PES") and accept responsibility for control and use of the PES contained therein.
- B. You also acknowledge You have read the DMM 604.4, Postage Payment Methods, Postage Meters and PC Postage Products (Postage Evidencing Systems) and agree to abide by all rules and regulations governing its use.
- C. Failure to comply with the rules and regulations contained in the DMM or use of the PES in any fraudulent or unlawful scheme or enterprise may result in the revocation of this Rental Agreement.
- D. You further acknowledge that any use of this PES that fraudulently deprives the USPS of revenue can cause You to be subject to civil and criminal penalties applicable to fraud and/or false claims against the United States. The submission of a false, fictitious or fraudulent statement can result in imprisonment of up to five (5) years and fines of up to \$10,000 (18 U.S.C. 1001). In addition, a civil penalty of up to \$5,000 and an additional assessment of twice the amount falsely claimed may be imposed (3 U.S.C. 3802).
- E. You further understand that the rules and regulations regarding use of this PES as documented in the USPS Domestic Mail Manual may be updated from time to time by the USPS and it is Your obligation to comply with any current or future rules and regulations regarding its use.
- F. You are responsible for immediately reporting (within seventy-two hours or less) the theft or loss of the postage meter that is subject to this Rental Agreement. Failure to comply with this notification provision in a timely manner may result in the denial of refund of funds remaining on the postage meter at the time of the loss or theft.

POSTAGE FUNDING ACCOUNT AGREEMENT

1. Incorporation of Certain Terms. You acknowledge that You have entered a Government Product Lease Agreement with Quadient Leasing USA, Inc. (the "Lease") and a Postage Meter Rental Agreement with Quadient, Inc. (the "Rental Agreement"). If you have an eligible postage meter, then you will have access to a postage funding account and this Postage Funding Account Agreement ("Account Agreement") shall govern Your use of such account. Any defined terms in the Lease or Rental Agreement shall have the same meanings in this Account Agreement, except that "We," "Us," and "Our," refer to Quadient Finance USA, Inc. Sections 14 through 20 of the Lease are hereby



incorporated into this Account Agreement except that any reference in those sections to the "Lease" refers to this Account Agreement.

2. Establishment and Activation of Account. You hereby authorize Us, to establish an account in Your name ("Account") for funding the purchase of postage from the United State Postal Service ("USPS") for use in the postage meter. Your Account may also be used to purchase supplies, pay for the Postage Meter rental, and obtain certain other products and services from Quadiant, Inc. The establishment of Your Account shall be subject to Our approval of Your creditworthiness. Any use of the Account shall constitute Your acceptance of all the terms and conditions of this Account Agreement and all other documents executed or provided in connection with the Account. The Account may not be used for personal, family, or household purposes.

3. Operation of Account. Each time an employee or agent of Yours with the express, implied, or apparent authority to do so (each an "Authorized User") uses the Account to receive a postage meter reset or obtain other products or services that Quadiant, Inc. is authorized to provide, Quadiant, Inc. will notify Us of the amount to be applied to Your Account balance. If the Account is used to obtain postage, then We will transfer the requested amount of postage to the USPS on Your behalf and Your Account will be charged for the amount of postage requested and any related fees, if applicable. You can continue to pre-pay the USPS for postage and understand that pre-paid postage funds will be used first to pay for my postage meter resets. You further understand that the Account will provide additional available postage funds when Your pre-paid account balance is zero (\$0). When You request a postage meter reset, if You have the funds on account with the USPS, those funds automatically will be withdrawn first to pay for postage, and any additional amounts due for postage and related fees will be billed through the Account under the terms and conditions of this Account Agreement. If the Account is used to acquire products or services from that Quadiant, Inc. is authorized to provide, then We shall pay the applicable amount to Quadiant, Inc. and add such amount to Your Account balance.

4. Payment Terms. You will receive a billing statement for each billing cycle in which You have any activity on Your Account. Payments are due on the due date shown on Your billing statement. You may pay the entire balance due or a portion of the balance, provided that You pay at least the minimum payment amount shown on Your statement. However, if You have exceeded the Account Limit, then You must pay the entire amount of any overage, as well as the minimum payment amount shown on Your statement. Whenever there is an unpaid balance outstanding on Your Account which is not paid in full by the due date shown on Your billing statement, We will charge You, and You agree to pay, interest on the unpaid balance of the Account for each day from the date the transaction is posted to Your Account until the date the unpaid balance is paid in full, at the Annual Percentage Rate (as defined below). The Account balance that is subject to a finance charge each day will include outstanding balances, minus any payments and credits received by Us on Your Account that day. The Annual Percentage Rate applicable to Your Account will be equal to the lesser of eighteen percent (18.00%) per annum or the maximum permitted by law. Each payment will be applied to reduce the outstanding balance of Your Account and replenish the amount available to You. We may refuse to extend further credit if the amount of a requested charge plus Your existing balance exceeds Your Account Limit.

5. Account Limit and Account Fees. You agree that We will establish a credit limit on Your Account (the "Account Limit"). The exact amount of the Account Limit will be indicated on Your invoice. We may, in Our sole discretion, allow Your balance to exceed the Account Limit. In the event We do so, You agree to pay Us an additional fee equal to one percent (1%) of the amount by which the Account Limit is exceeded for each transaction that You initiate after Your Account has reached the Account Limit. Such amount will be charged to Your Account on the date that the relevant transaction(s) occurs. Unless prohibited by applicable law, You agree to pay the amounts set forth in this Account Agreement, which may include, without limitation, the amounts specified above, a fee for a late payment, a fee for any checks that are returned as a result of insufficient funds, and a fee for any ACH direct debit transactions which are rejected, and an annual account fee. All such fees shall be added to Your Account balance.

6. Cancellation and Suspension. We may at any time close or suspend Your Account or temporarily refuse to allow further charges to Your Account. You can cancel Your Account at any time by notifying Us in writing at the address provided on Your Account statement of Your desire to do so. No cancellation or suspension will affect Your obligation to pay any amounts You then owe under this Account Agreement. We will notify You of the Account balance in the event of any termination and all outstanding obligations will survive the termination of this Account Agreement by either party.

7. Default. We may declare You in default if You: (i) have made any misrepresentations to Us; (ii) at any time, have done or allowed anything that indicates to Us that You may be unable or unwilling to repay the balance of Your Account as required under this Account Agreement; or (iii) are in default under this Account Agreement or any lease, rental, or other agreement with Us, Quadiant, Inc., or their affiliates. If You are in default, or upon any cancellation of Your Account, We shall not be obligated to continue to provide the Account service or extend further credit under this Account Agreement. If We are required to take collection action or any other legal action under this Account Agreement, You shall pay upon demand by Us all court and collection costs, along with reasonable attorney's fees. These remedies shall be cumulative and not exclusive, and shall be in addition to any and all other remedies available to Us.

8. Remedies. If We have declared that You are in default under this Account Agreement, then We may: (i) declare all agreements You have with Us in default and due and payable at once without notice or demand; (ii) refuse to make further advances on Your behalf to reset Your postage meter; and (iii) exercise any other rights that We may have. In addition, You agree that any default under this Account Agreement shall constitute a default under any agreement You may have with any of Our affiliates, including, but not limited to, Quadiant, Inc., Quadiant Leasing USA, Inc.

9. Amendments. We may amend this Account Agreement, or any of its provisions, including without limitation any fees and charges and/or the Annual Percentage Rate, at any time by at least thirty (30) days written notice to You, and such written notice may be included in Your billing statement. Any such amendment will become effective on the date stated in the notice and will apply to any transactions after such date, as well as to any outstanding balance on Your Account.

10. Notice: Any notice required to be given under this Account Agreement by either party hereto shall be given if to You, at the



address shown on Your Order Form, and if to Us at 478 Wheelers Farms Road, Milford, CT 06461.

11. Miscellaneous. You understand that We may obtain credit reports in connection with Your Account now and in the future. This Account Agreement shall be governed by and construed in accordance with the laws of the State of Texas, without reference to its conflict-of-laws rules, and any applicable federal laws. The sole jurisdiction and venue for actions related to the subject matter hereof shall be in a State or Federal Court within the State of Texas.

MAINTENANCE AGREEMENT

1. Incorporation of Certain Terms. You acknowledge that You have entered a Government Product Lease Agreement with Quadiant USA, Inc. (the "Lease"). Any defined terms in the Lease shall have the same meanings in this Maintenance Agreement, except that "We," "Us," and "Our," refer to Quadiant, Inc. Sections 13 through 24 of the Lease are hereby incorporated into this Maintenance Agreement, except that any reference in those sections to the "Lease" refers to this Maintenance Agreement.

2. Quadiant's Terms and Conditions for Maintenance Services. If the Order Form indicates that You have purchased maintenance services, then Quadiant, Inc., or one of its affiliates, will provide maintenance services for the Products in accordance with Quadiant, Inc.'s then-current maintenance terms and pricing for the level of maintenance services that You have purchased. Those services will be provided for the entire term of the Lease and are NON-CANCELABLE. The current version of those terms and conditions are available at www.quadiant.com/usa-maintenance-program-terms. You agree that You have access to such terms and that they are incorporated into this Maintenance Agreement by this reference, and that You shall be bound by such terms as if they were fully stated herein. **Notwithstanding the foregoing, maintenance services are not available on HD Office Printer Series products.**

ONLINE SERVICES AND SOFTWARE AGREEMENT

1. Incorporation of Certain Terms. You acknowledge that You have entered a Government Product Lease Agreement with Quadiant Leasing USA, Inc. (the "Lease"). Any defined terms in the Lease shall have the same meanings in this Online Services and Software Agreement ("OSS Agreement"), except that "We," "Us," and "Our," refer to Quadiant, Inc. Sections 13 through 24 of the Lease are hereby incorporated into this OSS Agreement, except that any reference in those sections to the "Lease" refer to this OSS Agreement.

2. License Grant and Additional Terms. In exchange for the license fees that are included in Your Lease Payment, We hereby grant to You a nonexclusive, nontransferable license to use the Software products, including related documentation, described on the Order Form solely for Your own use on or with the Products. You warrant and represent that You will not sell, transfer, disclose or otherwise make available

such Software products or copies thereof to third parties; provided, however, that the Software products may be used by Your employees or independent contractors using the Products. No title or ownership of the Software products or any portion thereof is transferred to You. You acknowledge and agree that there may be additional terms and conditions that apply to Your use of any Software provided by Us. Such terms may be provided with the Software, or made available at www.quadiant.com/software-terms and may be supplemented by Us or third party licensors, from time to time, by notice to You. You acknowledge and agree that You have access to the appropriate version(s) of the applicable terms provided at the address above and corresponding to Software described on the Order Form at the time you enter this OSS Agreement. Such terms are incorporated herein by this reference and You agree to be bound by such terms as if they were fully stated herein.

3. Software Support. Unless otherwise specified in the applicable Software terms, if You have purchased support for the Software, We will provide the following for a period of one (1) year: (i) software updates and, if applicable, carrier rate updates that keep You current and compliant with supported carrier rates, fees, zone schedules, label, barcode and forms changes; (ii) updates to the Software; (iii) corrective bug fixes as released; and (iv) technical support for the Software (collectively "Software Maintenance"). At the conclusion of each year of Software Maintenance, the Software Maintenance will automatically renew for additional one-year periods at Our then-current fee for such services unless you give us at least sixty (60) days prior written notice that you wish to cancel the Software Maintenance. You acknowledge that the Software may fail to comply with applicable regulations if you do not have Software Maintenance and that We shall not have any liability in connection with any such failure. If You allow the Software Maintenance to lapse, You may reinstate such services; provided that you pay all fees that would have been due from the expiration of Your last Software Maintenance period through the reinstatement date, plus a 15% administrative surcharge.

4. Use of Websites. Quadiant, Inc. and/or any of Our affiliates, suppliers, including, but not limited to, Quadiant Leasing USA, Inc. may, from time to time, make certain websites available to You in order to provide You with certain services ("Websites"). If You access any such Websites, You acknowledge and agree that Your use of the Website is subject to the terms of use and/or license terms in effect at the time You use the Website. Such terms are available on the Websites for Your review. You acknowledge and agree that such terms may be supplemented and modified from time to time ("Supplemental Terms"). Your use of a Website after Supplemental Terms have been issued will signify Your acceptance of those terms. In the event of a conflict between the terms of this OSS Agreement and the Supplemental Terms, the Supplemental Terms shall control.

POSTAGE METER RENTAL AGREEMENT

1. Postage Meter Rental. In this Postage Meter Rental Agreement (the "Rental Agreement"), the words "You" and "Your" mean the customer named on the Postage Meter Rental Agreement order form ("Order Form"). "We," "Us" and "Our" mean Quadiant, Inc. You agree to rent from Us the postage meter identified on the Order Form, as well as any other products listed on the Order Form, together with all existing accessories, embedded software programs, attachments, replacements, additions and repairs, (the "Postage Meter") upon the terms stated herein.

2. Provisions as to Use and Notice of Reused Components. You acknowledge that: (i) as required by United States Postal Service regulations, the Postage Meter(s) is being rented to You and that it is Our property; (ii) the Postage Meter will be surrendered by You upon demand by Us; (iii) You are responsible for the control and use of the Postage Meter; (iv) You will comply with all applicable laws regarding Your use or possession of the Postage Meter; (v) the use of the Postage Meter is subject to the conditions established from time to time by the United States Postal Service; and (vi) the Postage Meter is to be used only for generating an indicia to evidence the prepayment of postage and to account for postal funds. It is a violation of Federal law to misuse or tamper with the Postage Meter and, if You do so, We may terminate this Rental Agreement upon notice to You. GUIDED BY QUADIANT, INC.'S SUSTAINABLE DESIGN AND RESPONSIBLE MANUFACTURING POLICY, THE PRODUCTS MAY CONTAIN REUSED COMPONENTS. For more information visit <https://www.quadiant.com/about-us/sustainable-design-and-manufacturing>.

3. Rental Fee, Payment and Term. The initial rental term for the Postage Meter is set forth on the Order Form ("Initial Term"). The rental fee for the Initial Term is also set forth on the Order Form. The Initial Term of this Rental Agreement will begin on the earlier of either the date the Postage Meter is installed or five (5) days after the Postage Meter is shipped by Us. You promise to pay to Us the amounts shown on the Order Form in accordance with the payment schedule set forth thereon, plus all other amounts stated on the Order Form or in this Rental Agreement. You shall make all payments to the address indicated on Our invoice within thirty (30) days of the date of Our invoice. A late fee will be charged if the payment is not made within such period and an additional late fee will be charged for each subsequent thirty (30) days that the invoice remains unpaid. You agree to pay Us the then-current fee charged by Our financial institution for checks returned unpaid and for ACH direct debit transactions which are rejected. You also agree to pay all setting fees and charges incurred in connection with the download of funds to the Postage Meter. The Postage Meter rental fee does not include the cost of consumable supplies. This Rental Agreement is NON-CANCELABLE during the Initial Term and any Renewal Period (as defined below). Unless, at least ninety (90) days before the end of the Initial Term, You: (i) notify Us that You intend to return the Postage Meter at the end of the Initial Term by calling 1-800-636-7678; and (ii) send written notice to Us in the manner We instruct You when You call, this Rental Agreement will automatically renew on a quarter-to-quarter basis, except as prohibited by law, at the then-current payment amount for such Postage Meter (each a "Renewal Period"). We will not notify You that the Initial Term or any Renewal Term is ending. You may terminate this Rental Agreement at the conclusion of any Renewal Period by giving Us thirty (30) days prior written notice of Your intent to do so.

4. Return of Postage Meter and Products. Upon the termination of this Rental Agreement, unless directed otherwise by Us, You shall, after receiving an Equipment Return Authorization ("ERA") number from Us, promptly send the Postage Meter and any other products, at Your

expense plus shipping and handling costs, to any location(s) that We designate in the contiguous United States. The Postage Meter must be properly packed for shipment with the ERA number clearly visible, freight prepaid and fully insured, and must be received in good condition, less normal wear and tear. Furthermore, You agree that if you fail to return a postage meter within thirty (30) days of receipt of the ERA from Us, then You will pay a postage meter replacement fee of one thousand dollars (\$1,000).

5. Postage Meter Maintenance, Inspections, and Location. We will keep the Postage Meter in good working condition during the term of this Rental Agreement. The United States Postal Service regulations may require Us to periodically inspect the Postage Meter. You agree to cooperate with Us regarding such inspections. We may, from time to time, access and download information from Your Postage Meter to provide Us with information about Your postage usage and We may share that information with Our distributors and other third parties and You hereby authorize Us to do so. You agree to promptly update Us whenever there is any change in Your name, address, telephone number, the licensing post office, or the location of the Postage Meter.

6. Loss; Damage; Insurance. You shall: (i) bear the risk of loss and damage to the Postage Meter and shall continue performing all of Your other obligations hereunder even if the Postage Meter becomes damaged or there is a loss, (ii) keep the Postage Meter insured against all risks of loss and damage in an amount at least equal to its full replacement cost.

7. Postage Advances. We do not sell postage. In the event You require an emergency advance for postage, We, at Our sole discretion, may advance You money to reset the Postage Meter. If We do provide such an advance, You agree to repay Us within five (5) days from the time of such advance: (i) the amount of the emergency advance; and (ii) the then-current advance fee.

8. Default. In the event You fail to perform in accordance with the terms set forth in this Rental Agreement, or any other Agreement with Us or any of Our affiliates, including, but not limited to Quadiant Finance USA, Inc., then We may, without notice: (i) repossess the Postage Meter(s); (ii) disable the Postage Meter; (iii) immediately terminate this Rental Agreement; and (iv) pursue any remedies available to Us at law or in equity. Furthermore, upon the return of the Postage Meter, You hereby authorize Us to offset any amount of postage remaining in the Postage Meter, prior to any refund to You, against any amount due to Us or any of Our affiliates. You shall also pay all of Our costs in enforcing Our rights under this Rental Agreement, including reasonable attorneys' fees and expenses that We incur to take possession, store, or repair, the Postage Meter, as well as any other expenses that We may incur to collect amounts owed to Us. These remedies shall be cumulative and not exclusive, and shall be in addition to any and all other remedies available to Us.

9. Rate Updates.

- A. Maintenance of Postal Rates. It is Your sole responsibility to ensure that correct amounts are applied as payment for mailing and shipping services. We shall not be responsible for returns for delivery delays, refusals, or any other problems caused by applying the incorrect rate to mail or packages.
- B. Rate Updates with Online Services. If the Order Form indicates that You are enrolled in Our Online Services program, then We will make available periodic updates for Your covered products and/or Postage Meter, including updates to maintain accurate USPS rates for the USPS services that are compatible with such products or Postage Meter. **The rate updates that are offered with Our Online Services program are only available for products that are Integrated (as defined below) into Your mailing machine.**



For the purposes of this section, "Integrated" means that the covered hardware cannot properly operate on a stand-alone basis and it has been incorporated into the mail machine. Products that are not Integrated including, but not limited to, all Software and scales with "ST-77," or "SE" in the model number will not receive updated rates as part of Our Online Services program (collectively "Excluded Products").

- C. Rate Updates with Rate Change Protection and Software Advantage. If You have any of Our Excluded Products, You may have elected to purchase Rate Change Protection ("RCP") from Us for Your hardware products or Software Advantage for Your Software. If the Order Form indicates that You have selected RCP or Software Advantage, We will make available the following updates for Your covered products or Software: (i) updates to maintain accurate rates for the services offered by the USPS and other couriers that are compatible with Your covered product or Software; and (ii) updates for major zip or zone changes that are compatible with Your covered product or Software. If any reprogramming is required because You have moved the products or Postage Meter to a new location, none of the services described in this Section cover the cost to do so. Customers with an outstanding Accounts Receivable balance may not receive a rate update until the open balance is resolved.

10. United States Postal Service Acknowledgement of Deposit Requirement. By signing this Postage Meter Rental Agreement, You acknowledge and agree that You have read the United States Postal Service Acknowledgement of Deposit (the "Acknowledgement") and will comply with its terms and conditions, as it may be amended from time to time.

11. Additional United States Postal Service Terms.

- A. By signing this Postage Meter Rental Agreement, You acknowledge that You are also entering into an Agreement with the United States Postal Service ("USPS") in accordance with the Domestic Mail Manual ("DMM") 604.4, Postage Payment Methods, Postage Meters and PC Postage Products (collectively, "Postage Evidencing Systems" or "PES") and accept responsibility for control and use of the PES contained therein.
- B. You also acknowledge You have read the DMM 604.4, Postage Payment Methods, Postage Meters and PC Postage Products (Postage Evidencing Systems) and agree to abide by all rules and regulations governing its use.
- C. Failure to comply with the rules and regulations contained in the DMM or use of the PES in any fraudulent or unlawful scheme or enterprise may result in the revocation of this Rental Agreement.
- D. You further acknowledge that any use of this PES that fraudulently deprives the USPS of revenue can cause You to be subject to civil and criminal penalties applicable to fraud and/or false claims against the United States. The submission of a false, fictitious or fraudulent statement can result in imprisonment of up to five (5) years and fines of up to \$10,000 (18 U.S.C. 1001). In addition, a civil penalty of up to \$5,000 and an additional assessment of twice the amount falsely claimed may be imposed (3 U.S.C. 3802).
- E. You further understand that the rules and regulations regarding use of this PES as documented in the USPS

Domestic Mail Manual may be updated from time to time by the USPS and it is Your obligation to comply with any current or future rules and regulations regarding its use.

- F. You are responsible for immediately reporting (within seventy-two hours or less) the theft or loss of the postage meter that is subject to this Rental Agreement. Failure to comply with this notification provision in a timely manner may result in the denial of refund of funds remaining on the postage meter at the time of the loss or theft.

12. Taxes. You agree to pay for all applicable taxes related to the sale or rental of any products or Postage Meter to You, as well as any taxes applicable to Your possession, and/or use of the products and/or Postage Meter. Furthermore, You agree to pay the applicable fee to cover Our expenses associated with the administration, billing and tracking of such charges and taxes.

13. Disclaimer of Warranties. EXCEPT AS EXPRESSLY STATED HEREIN, WE MAKE NO REPRESENTATIONS OR WARRANTIES OF ANY KIND, EXPRESS OR IMPLIED, REGARDING ANY MATTER WHATSOEVER, INCLUDING, BUT NOT LIMITED TO, THE SUITABILITY OF ANY PRODUCTS OR POSTAGE METER, ITS CONDITION, ITS MERCHANTABILITY, ITS FITNESS FOR A PARTICULAR PURPOSE, ITS FREEDOM FROM INFRINGEMENT, OR OTHERWISE.

14. Limitation of Liability. IN NO EVENT SHALL EITHER PARTY BE LIABLE TO THE OTHER PARTY FOR ANY INCIDENTAL, INDIRECT, SPECIAL, CONSEQUENTIAL OR PUNITIVE DAMAGES OF ANY KIND ARISING OUT OF, OR IN CONNECTION WITH, THIS AGREEMENT, WHETHER OR NOT SUCH PARTY WAS ADVISED OF THE POSSIBILITY OF SUCH DAMAGE. NOTWITHSTANDING ANY OTHER PROVISION OF THIS RENTAL AGREEMENT, EXCEPT FOR DIRECT DAMAGES RESULTING FROM PERSONAL INJURY OR DAMAGE TO TANGIBLE PROPERTY CAUSED BY OUR GROSS NEGLIGENCE OR WILLFUL MISCONDUCT, THE MAXIMUM OUR LIABILITY TO YOU FOR DAMAGES HEREUNDER SHALL NOT EXCEED THE TOTAL OF THE AMOUNTS PAID TO US HEREUNDER BY YOU.

15. Assignment. No right or interest in this Rental Agreement may be assigned by You, without Our prior written consent.

16. Notice. All notices related to this Rental Agreement to Us shall be made by You, or an attorney representing You. Notice of non-renewal of this Rental Agreement shall be made as outlined in Section 3 herein by calling 1-800-636-7678. All other notices, requests and other communications hereunder shall be in writing, and shall be considered given when: (i) delivered personally, or (ii) sent by commercial overnight courier with written confirmation of delivery. Written notices to Us shall be sent to: Quadiant, Inc., 478 Wheelers Farms Road, Milford, CT 06461 ("Notice Address").

17. Integration. This Rental Agreement represents the final and only agreement between You and Us regarding Your acquisition of the Postage Meter and any other products or services. There are no unwritten oral agreements between You and Us. This Rental Agreement can be changed only by a signed, written agreement between You and Us.

18. Severability. In the event any provision of this Rental Agreement shall be deemed to be invalid, illegal or unenforceable, the validity, legality and enforceability of the remaining provisions shall not in any way be affected or impaired thereby. The parties agree to replace any invalid provision with a valid provision, which most closely approximates the intent and economic effect of the invalid provision.

19. Waiver or Delay. A waiver of any default hereunder or of any term or condition of this Rental Agreement shall not be deemed to be



a continuing waiver or a waiver of any other default or any other term or condition, but shall apply solely to the instance to which such waiver is directed. We may accept late payments, partial payments, checks or money orders marked "payment in full," or with a similar notation, without compromising any rights under this Rental Agreement.

20. Choice of Law; Venue; and Attorney's Fees. This Rental Agreement shall be governed under the laws of the State of Missouri.

POSTAGE FUNDING ACCOUNT AGREEMENT

1. Incorporation of Certain Terms. You acknowledge that You have entered a Postage Meter Rental Agreement with Quadiant, Inc. (the "Rental Agreement"). If you have an eligible Postage Meter, then you will have access to a postage funding account and this Postage Funding Account Agreement ("Account Agreement") shall govern Your use of such account. Any defined terms in the Rental Agreement shall have the same meanings in this Account Agreement, except that "We," "Us," and "Our," refer to Quadiant Finance USA, Inc., an affiliate of Quadiant, Inc. Sections 10 through 19 of the Rental Agreement are hereby incorporated into this Account Agreement except that any reference in those sections to the "Rental Agreement" refers to this Account Agreement.

2. Establishment and Activation of Account. You hereby authorize Us, to establish an account in Your name ("Account") for funding the purchase of postage from the United State Postal Service ("USPS") for use in the Postage Meter. Your Account may also be used to purchase supplies, pay for the Postage Meter rental, and obtain certain other products and services from Quadiant Inc. The establishment of Your Account shall be subject to Our approval of Your creditworthiness. Any use of the Account shall constitute Your acceptance of all the terms and conditions of this Account Agreement and all other documents executed or provided in connection with the Account. The Account may not be used for personal, family, or household purposes.

3. Operation of Account. Each time an employee or agent of Yours with the express, implied, or apparent authority to do so (each an "Authorized User") uses the Account to receive a postage meter reset or obtain other products or services that Quadiant, Inc. is authorized to provide, Quadiant, Inc. will notify Us of the amount to be applied to Your Account balance. If the Account is used to obtain postage, then We will transfer the requested amount of postage to the USPS on Your behalf and Your Account will be charged for the amount of postage requested and any related fees, if applicable. You can continue to pre-pay the USPS for postage and understand that pre-paid postage funds will be used first to pay for my postage meter resets. You further understand that the Account will provide additional available postage funds when Your pre-paid account balance is zero (\$0). When You request a Postage Meter reset, if You have the funds on account with the USPS, those funds automatically will be withdrawn first to pay for postage, and any additional amounts due for postage and related fees will be billed through the Account under the terms and conditions of this Account Agreement. If the Account is used to acquire products or services that Quadiant Inc. is authorized to provide, then We shall pay

the applicable amount to Quadiant, Inc. and add such amount to Your Account balance.

4. Payment Terms. You will receive a billing statement for each billing cycle in which You have any activity on Your Account. Payments are due on the due date shown on Your billing statement. You may pay the entire balance due or a portion of the balance, provided that You pay at least the minimum payment amount shown on Your statement. However, if You have exceeded the Account Limit, then You must pay the entire amount of any overage, as well as the minimum payment amount shown on Your statement. Whenever there is an unpaid balance outstanding on Your Account which is not paid in full by the due date shown on Your billing statement, We will charge You, and You agree to pay, interest on the unpaid balance of the Account for each day from the date the transaction is posted to Your Account until the date the unpaid balance is paid in full, at the Annual Percentage Rate (as defined below). The Account balance that is subject to a finance charge each day will include outstanding balances, minus any payments and credits received by Us on Your Account that day. The Annual Percentage Rate applicable to Your Account will be equal to the lesser of eighteen percent (18.00%) per annum or the maximum permitted by law. Each payment will be applied to reduce the outstanding balance of Your Account and replenish the amount available to You. We may refuse to extend further credit if the amount of a requested charge plus Your existing balance exceeds Your Account Limit.

5. Account Limit and Account Fees. You agree that We will establish a credit limit on Your Account (the "Account Limit"). The exact amount of the Account Limit will be indicated on Your invoice. We may, in Our sole discretion, allow Your balance to exceed the Account Limit. In the event We do so, You agree to pay Us an additional fee equal to one percent (1%) of the amount by which the Account Limit is exceeded for each transaction that You initiate after Your Account has reached the Account Limit. Such amount will be charged to Your Account on the date that the relevant transaction(s) occurs. Unless prohibited by applicable law, You agree to pay the amounts set forth in this Account Agreement, which may include, without limitation, the amounts specified above, a fee for a late payment, a fee for any checks that are returned as a result of insufficient funds, a fee for any ACH direct debit transactions which are rejected, and an annual account fee. All such fees shall be added to Your Account balance.

6. Cancellation and Suspension. We may at any time close or suspend Your Account or temporarily refuse to allow further charges to Your Account. You can cancel Your Account at any time by notifying Us in writing at the address provided on Your Account statement of Your desire to do so. No cancellation or suspension will affect Your obligation to pay any amounts You then owe under this Account Agreement. We will notify You of the Account balance in the event of any termination and all outstanding obligations will survive the termination of this Account Agreement by either party.

7. Default. We may declare You in default if You: (i) have made any misrepresentations to Us; (ii) at any time, have done or allowed anything that indicates to Us that You may be unable or unwilling to repay the balance of Your Account as required under this Account Agreement; or (iii) are in default under this Account Agreement or any lease, rental, or other agreement with Us, Quadiant, Inc., or their affiliates. If You are in default, or upon any cancellation of Your Account, We shall not be obligated to continue to provide the Account service or extend further credit under this Account Agreement. If We are required to take collection action or any other legal action under this Account Agreement, You shall pay upon demand by Us all court and collection costs, along with reasonable attorney's fees. These



remedies shall be cumulative and not exclusive, and shall be in addition to any and all other remedies available to Us.

8. Remedies. If We have declared that You are in default under this Account Agreement, then We may: (i) declare all agreements You have with Us in default and due and payable at once without notice or demand; (ii) refuse to make further advances on Your behalf to reset Your Postage Meter; and (iii) exercise any other rights that We may have. In addition, You agree that any default under this Account Agreement shall constitute a default under any agreement You may have with any of Our affiliates, including, but not limited to, Quadiant, Inc., Quadiant Leasing USA, Inc.

9. Amendments. We may amend this Account Agreement, or any of its provisions, including without limitation any fees and charges and/or the Annual Percentage Rate, at any time by at least thirty (30) days written notice to You, and such written notice may be included in Your billing statement. Any such amendment will become effective on the date stated in the notice and will apply to any transactions after such date, as well as to any outstanding balance on Your Account.

10. Notice: Any notice required to be given under this Account Agreement by either party hereto shall be given if to You, at the address shown on Your Order Form, and if to Us at 478 Wheelers Farms Road, Milford, CT 06461.

11. Miscellaneous. You understand that We may obtain credit reports in connection with Your Account now and in the future. This Account Agreement shall be governed by and construed in accordance with the laws of the State of Texas, without reference to its conflict-of-laws rules, and any applicable federal laws. The sole jurisdiction and venue for actions related to the subject matter hereof shall be in a State or Federal Court within the State of Texas.

ONLINE SERVICES AND SOFTWARE AGREEMENT

1. Incorporation of Certain Terms. You acknowledge that You have entered a Postage Meter Rental Agreement with Quadiant, Inc. (the "Rental Agreement"). Any defined terms in the Rental Agreement shall have the same meanings in this Online Services and Software Agreement ("OSS Agreement"). Sections 12 through 20 of the Rental Agreement are hereby incorporated into this OSS Agreement, except that any reference in those sections to the "Rental Agreement" refers to this OSS Agreement.

2. License Grant and Additional Terms. In exchange for the license fees that are included in Your Rental Payment, We hereby grant to You a nonexclusive, nontransferable license to use the Software products, including related documentation, described on the Order Form solely for Your own use on or with the Postage Meter and other products. You warrant and represent that You will not sell, transfer, disclose or otherwise make available such Software products or copies thereof to third parties; provided, however, that the Software products may be used by Your employees or independent contractors using the Postage Meter and other products. No title or ownership of the Software products or any portion thereof is transferred to You. You acknowledge and agree that there may be additional terms and conditions that apply to Your use of any Software provided by Us. Such terms may be provided with the Software, or made available at www.quadiant.com/software-terms and may be supplemented by Us or third party licensors, from time to time, by notice to You. You acknowledge and agree that You have access to the appropriate

version(s) of the applicable terms provided at the address above and corresponding to Software described on the Order Form at the time you enter this OSS Agreement. Such terms are incorporated herein by this reference and You agree to be bound by such terms as if they were fully stated herein.

3. Software Support. Unless otherwise specified in the applicable Software terms, if You have purchased support for the Software, We will provide the following for a period of one (1) year: (i) software updates and, if applicable, carrier rate updates that keep You current and compliant with supported carrier rates, fees, zone schedules, label, barcode and forms changes; (ii) updates to the Software; (iii) corrective bug fixes as released; and (iv) technical support for the Software (collectively "Software Maintenance"). At the conclusion of each year of Software Maintenance, the Software Maintenance will automatically renew for additional one-year periods at Our then-current fee for such services unless you give us at least sixty (60) days prior written notice that you wish to cancel the Software Maintenance. You acknowledge that the Software may fail to comply with applicable regulations if you do not have Software Maintenance and that We shall not have any liability in connection with any such failure. If You allow the Software Maintenance to lapse, You may reinstate such services; provided that you pay all fees that would have been due from the expiration of Your last Software Maintenance period through the reinstatement date, plus a 15% administrative surcharge.

4. Use of Websites and SaaS Services. Quadiant, Inc. and/or any of Our affiliates, or suppliers, including, but not limited to, Quadiant Leasing USA, Inc. may, from time to time, make certain content and/or services available to You via the Internet ("Websites") in order to provide You with certain services, including, but not limited to, software as a service solutions. If You access any such Websites, You acknowledge and agree that Your use of the Website is subject to the terms of use and/or subscription terms in effect at the time You use the Website. Such terms are available on the Websites for Your review. You acknowledge and agree that such terms may be supplemented and modified from time to time ("Supplemental Terms"). Your use of a Website after Supplemental Terms have been issued will signify Your acceptance of those terms. In the event of a conflict between the terms of this OSS Agreement and the Supplemental Terms, the Supplemental Terms shall control.



**The State of Arizona
State Procurement Office**

In conjunction with



**NASPO ValuePoint Master Agreement for
Mailing Equipment, Supplies and
Maintenance**

(Effective May 15, 2022)

Resulting from Request for Proposals
Arizona Solicitation Number BPM003137



Request for Proposal
Solicitation No. **BPM003137**
Description:
Mailing Equipment, Supplies, and Maintenance

Arizona Department of Administration
State Procurement Office
100 N 15th Ave., Suite 402
Phoenix, AZ 85007

Attachment 1
Offer and Acceptance Form

SUBMISSION OF OFFER: Undersigned hereby offers and agrees to provide *Mailing Equipment, Supplies, and Maintenance* in compliance with the Solicitation indicated above and our Offer indicated by the latest dated version below:

Initial Offer:	1.	9/1/2021							
		Date	initial						
Revised Offers:	2.	X	X	3.	X	X	4.	X	X
		date #1	initial	date #1	initial	date #1	initial		
	5.	X	X	6.	X	X	7.	X	X
		date #4	initial	date #5	initial	date #6	initial		
Best and Final Offer:	8.	X	X						
		Date	initial						

Quadient, Inc.

Offeror company name

X

Signature of person authorized to sign Offer

478 Wheelers Farms Rd.

Address

John Tartaro Deputy, CFO

Printed name and title

Milford, CT 06461

City | State | ZIP

Larry Waters Manager Government Accounts

Contact name and title

94-2388882

Federal tax identifier (EIN or SSN)

l.waters@quadient.com

Contact Email Address

281-216-4596

Contact phone number

CERTIFICATION: By signature in the above, Offeror certifies that it:

- will not discriminate against any employee or applicant for employment in violation of Federal Executive Order 11246, [Arizona] State Executive Order 2009-9 or A.R.S. §§ 41-1461 through 1465;
- has not given, offered to give, nor intends to give at any time hereafter any economic opportunity, future employment, gift, loan, gratuity, special discount, trip, favor, or service to a public servant in connection with the submitted offer. Failure to provide a valid signature affirming the stipulations required by this clause will result in rejection of the Offer. Signing the Offer with a false statement will void the Offer, any resulting contract, and may be subject to legal penalties under law;
- complies with A.R.S. § 41-3532 when offering electronics or information technology products, services, or maintenance; and
- is not debarred from, or otherwise prohibited from participating in any contract awarded by federal, state, or local government.

ACCEPTANCE OF OFFER: State hereby accepts the initial Offer, Revised Offer, or Best and Final Offer identified by the latest date and number at the top of this form (the Accepted Offer). Offeror is now bound (as Contractor) to carry out the Work under the attached Contract, of which the Accepted Offer forms a part. Contractor is cautioned not to commence any billable work or to provide any material or perform any service under the Contract until Contractor receives the applicable Order or written notice to proceed from Procurement Officer.

State's Contract No. is: **CTR058809**

The effective date of the Contract is: **5/15/2022** Date Contract awarded **1/25/2022** Date

Procurement Officer Signature

Nyesha Daley, PhD

Procurement Officer Printed Name



Request for Proposal
 Solicitation No. **BPM003137**
 Description:
Mailing Equipment, Supplies, and Maintenance

Arizona Department of Administration
State Procurement Office
 100 N 15th Ave., Suite 402
 Phoenix, AZ 85007

Attachment 3-A
Method Proposal (Method of Approach)

The Offeror shall provide a narrative response to each question that demonstrates their understanding of the Scope of Work requirements and describes your company's overall method of approach for providing the service stated in this solicitation. If there is a question that is not applicable to the services required by the Scope of Work, you may mark it N/A.

Question 1: Proposed Offering:

Bidder shall identify which categories are being offered.

<input checked="" type="checkbox"/>	<u>Postage Meter Rental (to include Legacy Postage Meters)</u>
<input checked="" type="checkbox"/>	<u>Mailing Systems, Ultra Low Volume</u>
<input checked="" type="checkbox"/>	<u>Mailing Equipment, Mailing Systems, Low Volume</u>
<input checked="" type="checkbox"/>	<u>Mailing Equipment, Mailing Systems, Medium Volume</u>
<input checked="" type="checkbox"/>	<u>Mailing Systems, High Volume</u>
<input checked="" type="checkbox"/>	<u>Mailing System, Production</u>
<input checked="" type="checkbox"/>	<u>Integrated Postal Scales</u>
<input checked="" type="checkbox"/>	<u>Letter Openers, Low Volume</u>
<input checked="" type="checkbox"/>	<u>Letter Openers, High Volume</u>
<input checked="" type="checkbox"/>	<u>Letter Folders, Low Volume</u>
<input checked="" type="checkbox"/>	<u>Letter Folders, High Volume</u>
<input type="checkbox"/>	<u>Inserters, Production</u>
<input checked="" type="checkbox"/>	<u>Folder/Inserters, Low volume</u>
<input checked="" type="checkbox"/>	<u>Folders/Inserters, Medium Volume</u>
<input checked="" type="checkbox"/>	<u>Folders/Inserters, High Volume</u>
<input checked="" type="checkbox"/>	<u>Folders/Inserters, Production</u>
<input type="checkbox"/>	<u>Envelope Mail Labeler, Low Volume</u>
<input type="checkbox"/>	<u>Envelope Mail Labeler, Medium Volume</u>
<input type="checkbox"/>	<u>Envelope Mail Labeler, High Volume</u>
<input type="checkbox"/>	<u>Envelope Mail Labeler, Production</u>
<input checked="" type="checkbox"/>	<u>Envelope Addressing System, Ink Jet, Low Volume</u>
<input checked="" type="checkbox"/>	<u>Envelope Addressing System, Ink Jet, Medium Volume</u>
<input checked="" type="checkbox"/>	<u>Envelope Addressing System, Ink Jet, High Volume</u>
<input checked="" type="checkbox"/>	<u>Envelope Addressing System, Ink Jet, Production</u>
<input checked="" type="checkbox"/>	<u>Tabbers, Low Volume</u>
<input checked="" type="checkbox"/>	<u>Tabbers, Medium Volume</u>
<input checked="" type="checkbox"/>	<u>Tabbers, High Volume</u>
<input type="checkbox"/>	<u>Tabbers, Production</u>
<input type="checkbox"/>	<u>Check Imprinting/Endorsing</u>
<input checked="" type="checkbox"/>	<u>Pressure Sealing, Production</u>
<input type="checkbox"/>	<u>Bursting Equipment, Production</u>
<input checked="" type="checkbox"/>	<u>Pre-sorting Equipment, Production</u>
<input checked="" type="checkbox"/>	<u>Extractors</u>
<input checked="" type="checkbox"/>	<u>Mailing Furniture (general)</u>
<input checked="" type="checkbox"/>	<u>Software, License and Subscription</u>
<input checked="" type="checkbox"/>	<u>Software Integration</u>
<input type="checkbox"/>	

Table of Contents

Section 1	NASPO ValuePoint Solicitation - General Information
Section 2	Solicitation Requirements, Information and Instructions to Offerors
Section 3	Scope of Work
Section 4	NASPO ValuePoint Master Agreement Statement of Compliance
Section 5	Price and Cost Proposal
Section 6	NASPO ValuePoint Master Agreement Terms and Conditions
Section 7	Lead State (State of Arizona) Terms & Conditions <i>7.1 State of Arizona Special Terms and Conditions</i> <i>7.2 State of Arizona Uniform Terms and Conditions</i>
Attachments	Additional Participating States' Terms and Conditions

REQUEST FOR PROPOSAL

Mailing Equipment, Supplies and Maintenance

Solicitation # BPM003137

Section 1: NASPO ValuePoint Solicitation - General Information

1.1. Purpose

The State of Arizona, State Procurement Office (“Lead State”) is requesting proposals for Mailing Equipment, Supplies and Maintenance in furtherance of the NASPO ValuePoint Cooperative Purchasing Program. The purpose of this Request for Proposals (RFP) is to establish multiple Master Agreements, by category with qualified Offerors to provide Mailing Equipment, Supplies and Maintenance to meet the mailing needs for all Participating States.

The objective of this RFP is to leverage the collective volume of potential purchases by numerous state and local government entities to obtain best value, and achieve more favorable pricing than is obtainable by an individual state or local government entity. The Master Agreement(s) resulting from this procurement may be used by state governments (including departments, agencies, institutions), institutions of higher education, political subdivisions (e.g., colleges, school districts, counties, cities, etc.), the District of Columbia, territories of the United States, and other eligible entities subject to approval of the individual state procurement director and compliance with local statutory and regulatory provisions. The initial term of the Master Agreement shall be two (2) years with renewal provisions as outlined in Section 6, NASPO ValuePoint Program Provisions, 3. Term of the Master Agreement NASPO ValuePoint Master Terms and conditions.

It is anticipated that this RFP may result in Master Agreement awards to multiple contractors, in the Lead State’s discretion.

This RFP is designed to provide interested Offerors with sufficient information to submit proposals meeting minimum requirements, but is not intended to limit a proposal's content or exclude any relevant or essential data. Offerors are encouraged to expand upon the specifications to add service and value consistent with state requirements.

This RFP is a replacement for the expiring Mailroom Equipment, Supplies and Maintenance Master Agreements for the State of Arizona and NASPO ValuePoint.

1.2. Lead State, Solicitation Number and Lead State Contract Administrator

The State of Arizona, State Procurement Office is the Lead State and issuing office for this document and all subsequent Amendments relating to it. This solicitation (RFP) is a competitive process, in accordance with the Arizona Procurement Code available at <https://spo.az.gov/>. The Arizona Procurement Code is a compilation in one place of

Arizona Revised Statutes (ARS) 41-2501 et seq. and administrative rules and regulations A.A.C. R2-7-1010 et seq. The solicitation # BPM003137 must be referred to on all proposals, correspondence, and documentation relating to this RFP.

The Lead State Contract Administrator identified below is the single point of contact during this procurement process. Offerors and interested persons shall direct to the Lead State Contract Administrator all questions concerning the procurement process, technical requirements of this RFP, contractual requirements, requests for brand approval, changes, clarifications, and protests, the award process, and any other questions that may arise related to this solicitation and the resulting Master Agreement. The Lead State Contract Administrator designated by the State of Arizona, State Procurement Office is:

Nyesha Daley, PhD, Statewide Procurement Manager
State of Arizona, State Procurement Office
100 N. 15th Avenue
Phoenix, Arizona 85007
Email: nyesha.daley@azdoa.gov
Phone: 602-542-4907

1.3 Schedule of Events

All dates and times are listed in the State's e-procurement system

Solicitation Release:	July 6, 2021
Pre-Proposal Conference:	July 19, 2021
Closing Date and Time:	August 17, 2021
Anticipated Award Date:	November 1, 2021

All times are Mountain Standard time unless indicated otherwise.

1.4. Definitions of Terms

The following definitions apply to this solicitation. Section 6 also contains definitions of terms used in this solicitation and the NASPO ValuePoint Master Agreement terms and conditions.

1.1 Arizona Procurement Code; A.R.S.; A.A.C.	"Arizona Procurement Code" means, collectively, Title 41 Chapter 23, <i>et. sequitur</i> , in the Arizona Revised Statutes (abbreviated "A.R.S.") and administrative rules R2-7-101 <i>et. sequitur</i> in the Arizona Administrative Code (abbreviated "A.A.C.").
-----------------------------------------------------	--------------------------------------------------------------------------------------------------------------------------------------------------------------------------------------------------------------------------------------------------------------------

NOTE: There are frequent references to the Arizona Procurement Code throughout the Solicitation Documents,

therefore, you will need to be familiar with its provisions to be able to understand the Solicitation Documents fully.

The Arizona Department of Administration State Procurement Office provides a reference compilation of the Arizona Procurement Code on its website:

<https://spo.az.gov/administration-policy/state-procurement-resource/procurement-regulations>

The Arizona State Legislature provides the official A.R.S. online at:

<http://www.azleg.gov/ArizonaRevisedStatutes.asp>

The Office of the Arizona Secretary of State provides the official A.A.C. online at:

<http://www.azsos.gov/rules/arizona-administrative-code>

- 1.2 Clarifications** “Clarifications” means, per A.A.C. R2-7-C313, communications between the Procurement Officer and Offeror for the purpose of providing a greater mutual understanding of the Offer. Clarifications may include demonstrations, questions and answers, or elaborations on previously-submitted information.
- 1.3 Contract** “Contract” is defined in paragraph 1.2 of the Uniform Terms and Conditions.
- 1.4 Contract Amendment** “Contract Amendment” is defined in paragraph 1.3 of the Uniform Terms and Conditions.
- 1.5 Contract Terms and Conditions** “Contract Terms and Conditions” is defined in paragraph 1.8 of the Special Terms and Conditions.
- 1.6 Contractor** “Contractor” is defined in paragraph 1.4 of the Uniform Terms and Conditions.
- 1.7 Evaluation** “Evaluation” means, per A.A.C. R2-7-C316, the process whereby the Procurement Officer will determine which Responsive offers, revised offers, and best and final offers are the most advantageous to State taking into consideration the evaluation factors set forth in the Solicitation Documents.
- 1.8 Negotiation** “Negotiation” means, per A.A.C. R2-7-101(32), an exchange or series of exchanges between State and an offeror for the purposes set forth in A.A.C. R2-7-C314.

- 1.9 Not Susceptible for Award** “Not Susceptible for Award” means, per A.A.C. R2-7-C311, that the relevant offer has been determined by the Procurement Officer to fail one or more of the tests and comparisons set forth therein. NOTE: A determination of Not Susceptible for Award and a determination of Responsive are mutually exclusive.
- 1.10 Offer: Initial Offer; Revised Offer; Best and Final Offer (BAFO)** “Initial Offer” means, per A.A.C. R2-7-101(33), Offeror’s proposal submitted to State in response to the Solicitation, as initially submitted.
 “Revised Offer” means any revised versions of the Initial Offer that Offeror has submitted to State at State’s request as permitted under A.A.C. R2-7-C314 and R2-7-C315.
 “Best and Final Offer” (“BAFO”) means, per A.A.C. R2-7-101(8), the Revised Offer submitted after negotiations have been completed that contain Offeror’s most favorable terms for price, service, and products to be delivered.
 Reference to “an Offer, “the Offer,” or “your Offer” means any of the Initial Offer, a Revised Offer, or the Best and Final Offer.
- 1.11 Offeror** “Offeror” is the Person submitting an Offer; instructions addressed to “you” and references to “your” items are to be construed as being synonymous with “Offeror” and “Offeror’s” throughout these Instructions to Offerors.
- 1.12 Pricing Document** “Pricing Document” means Section 2-B of the Solicitation Documents. Also known as Pricing Document as defined in the Special Terms and Conditions.
- 1.13 The State’s e-Procurement System** “The State’s e-Procurement System” is defined in paragraph 1.16 of the Special Terms and Conditions.
- 1.14 Procurement Officer** “Procurement Officer” means the person, or his or her designee, who has been duly authorized by State to administer the Solicitation and make written determinations with respect to the Solicitation. The Procurement Officer is identified in The State’s e-Procurement System.
- 1.15 Small Business** “Small Business” means a for-profit or not-for-profit organization, including its affiliates, with fewer than 100 full-time employees or gross annual receipts of less than \$4 million for the last complete fiscal year.
- 1.16 Solicitation** “Solicitation” means this procurement solicitation, which State is issuing as either:

1. an invitation for bids ("IFB") under A.R.S. § 41-2533;
2. a request for proposals ("RFP") under A.R.S. § 41-2534;
3. a request for quotations ("RFQ") under A.R.S. § 41-2535;
or
4. a request for qualifications under A.R.S. §41-2558.

Refer to the Solicitation Summary for which of the foregoing is this Solicitation.

- 1.17 Solicitation Amendment** "Solicitation Amendment" means, per A.A.C. R2-7-101(15), a change to the Solicitation that has been issued by Procurement Officer.
- 1.18 Solicitation Summary** "Solicitation Summary" means Section 1 of the Solicitation Documents.
- 1.19 State** "State" is defined in paragraph 1.11 of the Uniform Terms and Conditions.
- 1.20 Subcontract** "Subcontract" is defined in paragraph 1.13 of the Uniform Terms and Conditions.
- 1.21 Subcontractor** "Subcontractor" is defined in paragraph 1.19 of the Special Terms and Conditions.

Lead State means the State conducting this cooperative procurement, evaluation, and award.

Offeror means the company or firm who submits a proposal in response to this Request for Proposal.

Proposer has the same meaning as Offeror

Proposal means the official written response submitted by an Offeror in response to this Request for Proposal.

"Request for Proposals" or "RFP" or "Solicitation" means the entire solicitation document, including all parts, sections, exhibits, attachments, and Amendments.

1.5. NASPO ValuePoint Background Information

NASPO ValuePoint (formerly known as WSCA-NASPO) is a cooperative purchasing program of all 50 states, the District of Columbia and the territories of the United States. The Program is facilitated by the NASPO Cooperative Purchasing Organization LLC, a nonprofit subsidiary of the National Association of State Procurement Officials (NASPO), doing business as NASPO ValuePoint. NASPO is a non-profit association dedicated to strengthening the procurement community through education, research, and communication. It is made up of the directors of the central purchasing offices in each of the 50 states, the District of Columbia and the territories of the United States. NASPO ValuePoint facilitates administration of the cooperative group contracting consortium of state chief procurement officials for the benefit of state departments, institutions, agencies, and political subdivisions and other eligible entities (i.e., colleges, school districts, counties, cities, some nonprofit organizations, etc.) for all states, the District of Columbia, and territories of the United States. For more information consult the following websites www.naspovaluepoint.org and www.naspo.org.

1.6. Participating States

In addition to the Lead State conducting this solicitation, the following Participating States have requested to be named in this RFP as potential users of the resulting Master Agreement:

- California
- Hawaii
- Illinois
- Iowa
- Maryland
- Ohio
- Tennessee
- Texas
- Virginia
- Washington
- Wyoming

Other entities may become Participating Entities after award of the Master Agreement. Some States may have included special or unique terms and conditions for their state that will govern their state Participating Addendum. These terms and conditions are being provided as a courtesy to Proposers to indicate which additional terms and conditions may be incorporated into the state Participating Addendum after award of the Master Agreement. The Lead State will not address questions or concerns or negotiate other States' terms and conditions. The Participating States shall negotiate these terms and conditions directly with the awarded supplier. State-specific terms and conditions are included in Attachments.

1.7. Anticipated Usage

No minimum or maximum level of sales volume is guaranteed or implied.

Section 2: Solicitation Requirements, Information and Instructions to Offerors

2.1. Pre-Offer Conference

A Pre-Offer Conference will be held at the time and place indicated in the solicitation's "Pre-Bid Conference" field as found within the State of Arizona's e-procurement system APP (<https://app.az.gov>); attendance is not required. The purpose of this conference will be to clarify the contents of the solicitation in order to prevent any misunderstanding of the State of Arizona's position. Any doubt as to the requirements of the solicitation or any apparent omission or discrepancy should be presented to the State of Arizona at the conference. The State of Arizona will then determine the appropriate action necessary, if any, and issue a written amendment to the solicitation if required. Oral statements or instructions will not constitute an amendment to the solicitation. Persons with a disability may request a reasonable accommodation, such as a sign language interpreter, or this document in an alternative format, by contacting the State of Arizona's Procurement Office listed on page 3. Requests should be made as early as possible to allow sufficient time to arrange for accommodation.

2.2. Inquiries

2.2.1 Solicitation Contact Person. Any inquiry related to this Solicitation, including any requests for inquiries regarding standards referenced in the Solicitation, shall be directed solely to the State of Arizona's Procurement Officer.

2.2.2 Submission of Inquiries. All inquiries to the State of Arizona's Procurement Officer related to the Solicitation are required to be submitted in the State of Arizona's E-Procurement System, APP (<https://app.az.gov>). All interested Proposers shall utilize the Q&A functionality provided through APP (<https://app.az.gov>). All responses to inquiries will be answered in the State's eProcurement system. Any inquiry related to the Solicitation should reference the appropriate solicitation page and paragraph number.

2.2.3 Duty to Examine. It is the responsibility of each Offeror to examine the entire Solicitation, seek clarification in writing (inquiries), and examine its Offer for accuracy before submitting an Offer. Lack of care in preparing an Offer shall not be grounds for modifying or withdrawing the Offer after the Offer due date and time.

2.2.4 Timeliness. Any inquiry or exception to the Solicitation shall be submitted as soon as possible and should be submitted at least seven days before the offer due date and time for review and determination by the State of Arizona. Failure to do so may result in the inquiry not being considered for a solicitation amendment.

2.2.5 No Right to Rely on Verbal or Electronic Mail Responses. An Offeror shall not rely on verbal or electronic mail responses to inquiries. A verbal or electronic mail reply to an inquiry does not constitute a modification of the solicitation.

2.3. Preparation of Proposals

2.3.1 Electronic Documents. This solicitation document is provided in an electronic format. Any unidentified alteration or modification to any solicitation documents, to any attachments, exhibits, forms, charts or illustrations contained herein shall be null and void. In those instances, where modifications are identified, the original document published by the State of Arizona shall take precedence.

2.3.2 Attachment Formats. All attachments shall be submitted in a format acceptable to the Lead State. Acceptable formats include .doc (Microsoft Word document), .xls (Microsoft Excel spreadsheet), and .pdf (Adobe Acrobat portable document format). Prospective Offerors that wish to submit attachments in other formats shall submit an inquiry to the Procurement Officer.

2.3.3 Confidential, Protected or Proprietary Information

All information identified in the "Confidential" section shall be subject to review by the Lead State in accordance with the procedures prescribed by the Lead State's open records statute, freedom of information act, or similar law.

2331 If a person believes that any portion of a proposal, bid, offer, specification, protest or correspondence contains a trade secret or other proprietary information that should be withheld, the Offeror shall clearly designate the trade secret and other proprietary information, using the term "Confidential" and, the State of Arizona's Procurement Officer shall be so advised in writing. An Offeror shall provide a statement detailing the reasons why the information should not be disclosed including the specific harm or prejudice that may arise upon disclosure. Such material shall be identified as "Confidential" wherever it appears. Until a written determination is made, the State of Arizona's Procurement Officer shall not disclose information designated as "Confidential" except to those individuals deemed to have a legitimate State interest. In the event the State of Arizona's Procurement Officer denies the request for confidentiality, the Offeror may appeal the determination to the State of Arizona's Procurement Administrator within the time specified in the written determination. The State of Arizona, pursuant to A.A.C. R2-7-103, shall review all requests for confidentiality and provide a written determination. If the confidential request is denied, such information shall be disclosed as public information, unless the person, requests a review of that determination under A.A.C. R2-7-103(D). **Contract terms and conditions, pricing, and information generally available to the public are not considered confidential information.**

2332 All Confidential, Protected or Proprietary information must be included in one section of your response. **Do not incorporate**

Confidential, Protected or Proprietary information throughout the Proposal.

2.3.3.2.1 In the event that a limited amount of “Confidential, Protected or Proprietary” information is deemed necessary by the Offeror to respond to solicitation, any such information must be included in a **separate section** of the Offeror’s proposal response which is clearly marked as “Confidential”. In addition, provide a reference in the proposal response directing reader to the specific area of this protected information section.

2.3.3.2.2 Offerors should be aware that marking any portion of an Offer as “Confidential”, may exclude the Offer from evaluation or consideration for award.

2.3.3.2.3 Elements of the proposal that define the contractual requirements, such as approaches to the statement of work, prices, and schedule, may not be marked as “Confidential”. Proposals not complying with these instructions for identification and segregation of confidential and proprietary information may be rejected.

2.3.3.2.4 Information included in the “Confidential” section of an Offeror’s proposal is not automatically accepted and protected.

2.3.4 Exceptions to Terms and Conditions.

All exceptions included with the Offer shall be submitted in the State of Arizona’s eProcurement system in the Conformance Statements included in Part 3 of the Offer in which the Offeror clearly identifies the specific paragraphs of the Solicitation where the exceptions occur. Any exceptions not included in such a section shall be without force and effect in any resulting Contract unless such exception is specifically accepted by the State of Arizona’s Procurement Officer in a written statement. An Offeror shall provide a statement detailing a justification for each exception item request. The Offeror’s preprinted or standard terms will not be considered by the State of Arizona as part of any resulting Contract. **All exceptions that are contained in the Offer may negatively impact an Offeror’s susceptibility for award. An Offer that takes exception to any material requirement of the solicitation may be rejected.**

2.3.5 Evidence of Intent to be Bound.

The Offer and Acceptance form within the Solicitation shall be submitted with the Offer in the State of Arizona's eProcurement system and shall include a signature by a person authorized to sign the Offer. The signature shall signify the Offeror's intent to be bound by the Offer and the terms of the Solicitation and that the information provided is true, accurate and complete. The Offer and Acceptance Form shall be submitted electronically with the submitted Offer no later than the Offer due date and time. Failure to return an Offer and Acceptance Form will result in rejection of the offer.

2.3.6 Subcontractors.

Offerors shall clearly list any proposed subcontractors. Include with their list of proposed subcontractors:

- Subcontractor's contact information;
- Subcontractor's certifications and or licenses required for the performance of the Contract; and,
- Subcontractor's proposed responsibilities under the Offeror's proposal.

2.3.7 Cost of Offer Preparation.

The State of Arizona will not reimburse any Offeror the cost of responding to a Solicitation.

2.3.8 Federal Excise Tax.

The State of Arizona is exempt from certain Federal Excise Tax on manufactured goods. Exemption Certificates will be provided by the Lead State.

2.3.9 Identification of Taxes in Offer.

The State of Arizona is subject to all applicable state and local transaction privilege taxes. If the products and/or services specified require transaction privilege or use taxes or other applicable taxes, they shall be described and itemized separately on the Offer. Arizona transaction privilege tax shall not be considered for evaluation.

2.3.10 Disclosure.

If the Offeror has been debarred, suspended or otherwise lawfully precluded from participating in any public procurement activity, including being disapproved as a subcontractor with any federal, state or local government, or if any such preclusion from participation from any public procurement activity is currently pending, the Offeror shall fully explain the circumstances relating to the preclusion or proposed preclusion in the Offer. The Offer shall set forth the name and address of the governmental unit, the effective date of the suspension or debarment, the duration of the suspension or debarment, and the relevant circumstances relating to the suspension of debarment. If suspension or debarment is currently pending, a detailed description of all relevant circumstances including the details enumerated above shall be provided.

2.3.11 Unit Price Prevails.

In the case of discrepancy between the unit price or rate and the extension of that unit price or rate, the unit price or rate shall govern.

2.3.12 Delivery.

Unless stated otherwise in the Solicitation, all prices shall be F.O.B. Destination and shall include all freight, delivery and unloading at the destination(s).

2.3.13 Federal Immigration and Nationality Act.

By signing of the Offer, the Offeror warrants that both it and all proposed subcontractors are in compliance with federal immigration laws and regulation (FINA) relating to the immigration status of their employees. The State of Arizona may, at its sole discretion require evidence of compliance during the evaluation process. Should the State of Arizona request evidence of compliance, the Offeror shall have five days from receipt of the request to supply adequate information. Failure to comply with this instruction or failure to supply requested information within the timeframe specified shall result in the Offer not being considered for contract award.

2.3.14 Offshore Performance of Work Prohibited.

Any services that are described in the specifications or scope of work that directly serve the State of Arizona or its clients and involve access to secure or sensitive data or personal client data shall be performed within the defined territories of the United States. Unless specifically stated otherwise in the specifications, this paragraph does not apply to indirect or 'overhead' services, redundant back-up services or services that are incidental to the performance of the contract. This provision applies to work performed by subcontractors at all tiers. Offerors shall declare all anticipated offshore services in the Offer.

2.4. Submission of Offer

2.4.1 Offer Submission, Due Date, and Time.

Offers in response to this solicitation shall be submitted within the Lead State's e- Procurement system, APP (<https://app.az.gov>). Offers shall be received before the date/time listed in the solicitation's 'Bid Due Date' field. Offers submitted outside of APP, or those that are received on or after the date/time stated in the 'Bid Opening Date' field, shall be rejected. Questions about the submission date and/or time shall be directed to the State of Arizona's Procurement Officer or to the APP Help Desk (app@azdoa.gov or 602.542.7600).

2.4.2 Offer Amendment or Withdrawal.

An Offer may not be amended or withdrawn after the offer due date and time except as otherwise provided under applicable law.

2.4.3 Electronic Submission of Offer.

2431

The successful submission of your offer in APP is critical in

order for it to be completely/properly received and evaluated. Prior review of the guides available via <https://app.az.gov> and on <https://spo.az.gov/> "Vendor Resources" tab can be of assistance in understanding the electronic submission process.

2432 The Lead State (State of Arizona) accepts no responsibility for a prospective Offeror not receiving solicitation documents and/or revisions to the solicitation. It is the responsibility of the prospective Offeror to monitor their emails for such notices and to monitor APP (<https://app.az.gov>) to obtain RFP addenda or other information relating to the RFP.

2.4.4 Non-collusion, Employment, and Services.

By signing the Offer and Acceptance form or other official contract form, the Offeror certifies that:

2441 The Offeror did not engage in collusion or other anti-competitive practices in connection with the preparation or submission of its Offer; and,

2442 The Offeror does not discriminate against any employee or applicant for employment or person to whom it provides services because of race, color, religion, sex, national origin, or disability, and that it complies with applicable federal, state and local laws and executive orders regarding employment.

2.4.5 Waiver and Rejection Rights:

Notwithstanding any other provision of the Solicitation, the State reserves the right to:

2451 Waive any minor informality;

2452 Reject any and all Offers or portions thereof; or,

2453 Cancel the Solicitation. If the Lead State (State of Arizona) determines such action to be in the collective best interests of Participating States, this solicitation may be canceled at any time, up until the time of award of the Master Agreement(s).

2.4.6 A responsive, responsible Offeror shall submit the following:

2461 Offer and Acceptance. Offers shall include a signed Offer and Acceptance form. The Offer and Acceptance form shall be signed with a signature by the person authorized to sign the Offer, and shall be submitted in the State of Arizona's eProcurement system with the Offer no later than the Solicitation due date and time. Failure to return an Offer and Acceptance form will result in rejection of the Offer.

2462 Acknowledgement of Solicitation Amendments. Offeror shall acknowledge Solicitation Amendments electronically in APP

(<https://app.az.gov>) no later than the Offer due date and time. Failure to acknowledge all/any Solicitation Amendments may result in rejection of the Offer.

2.4.6.2.1 Alternately to the electronic acknowledgement in APP, the Offeror can attach a counter-signed copy of each Amendment in APP as part of their Offer.

2463 Offer Forms: Offerors shall include all Offer Forms in part 3 of the solicitation, completed accurately, in the format provided and according to the instructions. Failure to follow Offer Form instructions will result in rejection of Offer.

2.5. References and Experience

The Offeror agrees that by submitting an Offer, the State of Arizona or its designated agent may contact any entities listed in the Offer or any entities known to have a previous business relationship with the Offeror for the purpose of obtaining references relative to past performance and verifying experience or other information submitted with the Offer. In addition, by submitting an Offer, the Offeror is agreeing to give permission to the entity to provide information and the Offeror will take whatever action is necessary to facilitate, encourage or authorized the release of information, if necessary, the Offeror shall sign a release to obtain information.

2.6 Responsibility

In accordance with A.R.S. §41-2534(G), A.A.C. R2-7-C312 and R2-7-C316, the State of Arizona shall consider, at a minimum, the following in determining Offeror's responsibility, as well, as the Offeror's responsiveness and acceptability for contract award.

2.6.1 Whether the Offeror has had a contract within the last five (5) years that was terminated for cause due to breach or similar failure to comply with the terms of the contract;

2.6.2 Whether the Offeror's record of performance includes factual evidence of failure to satisfy the terms of the Offeror's agreements with any party to a contract. Factual evidence may consist of documented vendor performance reports, customer complaints and/or negative references;

2.6.3 Whether the Offeror is legally qualified to contract with the State of Arizona and the Offeror's financial, business, personnel, or other resources, including subcontractors;

2.6.3.1 Legally qualified includes if the vendor or if key personnel have been debarred, suspended or otherwise lawfully

prohibited from participating in any public procurement activity, including but not limited to, being disapproved as a subcontractor of any public procurement unit or other governmental body.

- 2.6.4 Whether the Offeror promptly supplied all requested information concerning its responsibility;
- 2.6.5 Whether the Offer was sufficient to permit evaluation by the State of Arizona, in accordance with the evaluation criteria identified in this Solicitation or other necessary offer components. Necessary offer components include: attachments, documents or forms to be submitted with the offer, an indication of the intent to be bound, reasonable or acceptable approach to perform the Scope of Work, signed Solicitation Amendments, references to include experience verification, adequacy of financial/business/personal or other resources to include a performance bond and stability including subcontractors and any other data specifically requested in the Solicitation;
- 2.6.6 Whether the Offer was in conformance with the requirements contained in the Scope of Work, Terms and Conditions, and Instructions for the Solicitation and its Amendments, including the documents incorporated by reference;
- 2.6.7 Whether the Offer limits the rights of the State;
- 2.6.8 Whether the Offer includes or is subject to unreasonable conditions, to include conditions upon the State of Arizona or necessary for successful Contract performance. The State of Arizona shall be the sole determiner as to the reasonableness of a condition;
- 2.6.9 Whether the Offer materially changes the contents set forth in the Solicitation, which includes the Scope of Work, Terms and Conditions, or Instructions; and,
- 2.6.10 Whether the Offeror provides misleading or inaccurate information.

2.7. Responsiveness and Acceptability

Proposals that do not contain information sufficient to evaluate the proposal in accordance with the factors identified in the solicitation or other necessary proposal components may not be considered responsive and/or acceptable. Necessary components include an indication of the Offeror's intent to be bound, price proposal, solicitation amendments, bond and reference data as required.

2.8. Opening

Proposals received by the correct time and date will be opened and the name of

each Offeror will be publicly available through the State of Arizona's eProcurement system (<https://app.az.gov>). Proposals will not be available on the eProcurement system until after contract award.

2.9. Offer Acceptance Period

Responses to this RFP, including proposed costs, will be considered firm for one hundred and eighty (180) days after the proposal due date and time.

2.10. Clarifications

Upon receipt and opening of proposals submitted in response to this solicitation, the State may request oral or written clarifications, including demonstrations or questions and answers, for the sole purpose of information gathering or for eliminating minor informalities or correcting nonjudgmental mistakes in proposals. Clarifications shall not otherwise afford Offerors the opportunity to alter or change their proposal.

2.11 Oral Presentations

The State of Arizona may request oral presentations. If requested, the Offeror shall be available for oral presentations with no more than ten (10) business days' advance notice. Participants in the oral presentations should include the Offeror's key persons. Such oral presentations shall not otherwise afford an Offeror the opportunity to alter or change its Offer.

2.12. Evaluation

In accordance with the Arizona Procurement code A.R.S. § 41-2534, awards shall be made to the responsible Offeror(s) whose proposal is determined in writing to be the most advantageous to the State based upon the evaluation criteria listed below. The evaluation factors are listed in their relative order of importance:

1. Capacity of Offeror, Years of Experience
2. Method of Approach
3. Cost

Exceptions to the Terms and Conditions, may impact an Offeror's susceptibility for award.

2.13 Discussions

In accordance with A.R.S. § 41-2534, after the initial receipt of proposals, the State may conduct discussions with those Offerors who submit proposals determined by the State to be reasonably susceptible of being selected for award.

2.14. Best and Final Offer (BAFO)

If discussions are conducted, the State of Arizona shall issue a written request for Best and Final Offers (BAFO's). The request shall set forth the date, time and place

for the submission of BAFO's. BAFO's shall be requested only once; unless, the State of Arizona makes a determination that it is advantageous to conduct further discussions.

2.15 Contract Award

Award of a contract will be made to the most responsive and responsible Offeror(s), by category, whose proposal is determined to be the most advantageous to the State of Arizona based on the evaluation criteria set forth in the solicitation.

2.15.1 Number of Types of Awards.

2.15.1.1 Each State reserves the right to enter into a single Participating Addendum (PA) or enter into multiple PAs, whichever is most advantageous to the Participating State.

2.15.2 Contract Inception. An Offer does not constitute a Contract nor does it confer any rights on the Offeror to the award of a Contract. A Contract is not created until the Offer is accepted in writing by the State of Arizona's Procurement Officer's signature on the Offer and Acceptance form. A notice of award or of the intent to award shall not constitute acceptance of the Offer.

2.16 Public Record

All Proposals submitted in response to this Request for Proposal shall become the property of the State of Arizona and shall become a matter of Public Record available for review and must be retained by the State of Arizona for six years. Offers shall be open and available to public inspection through the State of Arizona's eProcurement system after Contract award, except for such Offers deemed to be confidential by the State of Arizona.

2.17 Protests

A protest shall comply with and be resolved according to Arizona Revised Statutes Title 41, Chapter 23, Article 9 and rules adopted thereunder. Protests shall be in writing and be filed with both the State of Arizona's Procurement Officer of the purchasing agency and with the State of Arizona's Procurement Administrator. A protest of a Solicitation shall be received by the State of Arizona's Procurement Officer before the Offer due date. A protest of a proposed award or of an award shall be filed within ten (10) days after the protester knows or should have known the basis of the protest. A protest shall include:

2.17.1 The name, address and telephone number of the protester;

2.17.2 The signature of the protester or its representative;

2.17.3 Identification of the purchasing agency and the Solicitation or Contract number;

- 2.17.4 A detailed statement of the legal and factual grounds of the protest including copies of relevant documents; and,
- 2.17.5 The form of relief requested.

Section 3: Scope of Work

Contractor shall provide equipment, services, and maintenance support to meet the mailing needs of the customer per the limitations of their award. The applicable product range will include, but not be limited to, software license and subscriptions, ultra-low volume equipment through equipment used in mailing production environments, including postage meter rental, accessories, supplies, and maintenance. All equipment and services offered must meet the approval of the USPS® if applicable.

3.2 Products

- 3.2.1 Any awarded contractor(s) shall also include, upon agency request, information on all environmental features of each item, including but not limited to: energy efficiency modes and their operation, double sided copying operations and double sided default programming, the extent to which any supplies and other packaging may qualify for recycling, re-manufacturing, and will provide the environmental and economic benefits of these features.
- 3.2.1.1. **Printers** – The only printers allowed for purchase through this solicitation are special printers sole use for which is tied to mailroom equipment. If a regular printer (e.g. an HP Printer) is able to be utilized in the same fashion, and function as the printer available from the Contractor, then the printer from the Contractor is not allowed. Allowable printers may be purchased with a mailroom equipment system or as a product replacement from a purchase from this or a previous Master Agreement.
- 3.2.1.2. **Computers** - The only computers allowed for purchase through this Master Agreement are those computers dedicated to mailroom equipment and operations.
- 3.2.1.3 **Furniture** - Furniture is being awarded within each category as well as being classified as an independent category. The furniture that is applicable to the independent furniture category is furniture that is specific to mailrooms but not specific to the mail equipment category. E.g. Case work or mobile mail cart etc. The furniture section within each category is relevant to furniture that would be considered specific to the Mailing Equipment with which they are compatible.
- 3.2.1.4 **Accessories** – All accessories, including tablets and scanners, shall be relevant to the functioning of a mailroom. If there is any concern over a specific item being included in this category, said items will be submitted to the Lead State Contract Administrator for a decision. The Lead State Contract Administrator's decision is the final determination as to whether an item is included in the Scope of any Master Agreement.

- ~~3.2.15~~ **Trade In/Buy Back** - Contractor shall provide a Trade in /Buy Back program to help ensure Participating Entity has the best options to meet their needs. This program is required; however, it is at the sole option of the Participating Entity to utilize this program.
- 3.2.16 All equipment identified as EnergyStar compliant shall be delivered and installed with the Energy Star or similar power management features enabled.

3.3. Remanufactured Equipment

- 3.3.1 A Contractor may offer Remanufactured or Refurbished Equipment that is certified by the Manufacturer. All Remanufactured or Refurbished Equipment will be clearly labeled as Remanufactured equipment. Pricing will be based on a quote and on an Individual Case Basis (ICB). Pricing must not exceed prices listed in approved price book at the time of purchase. All quotes will also provide the fixed annual maintenance rate for years 2-5. Remanufactured equipment shall come with a 1 year all-inclusive as new-warranty and the Offeror shall be able to provide maintenance for years 2-5 that includes all service, labor, software maintenance, and parts. If for any reason a Contractor is not able to provide maintenance (including parts), the Contractor(s) will provide, entirely at their expense, a replacement piece of equipment and/or software. Any replacement items shall have the equal or greater performance and functionality along with the maintenance for the equipment for the duration of the original five (5) year maintenance period (including maintenance on the replacement equipment) at no additional charge. All other requirements of the Master Agreement continue to apply.

3.4. Shipping and Delivery

- 3.4.1 Shipping is to be FOB destination, inside to the contiguous 48 states, Washington DC and point of exportation for Alaska, Hawaii, Puerto Rico, and territories for shipments outside the 48 contiguous states. The point of exportation location must be agreed to, in writing, by the vendor and the Participating Entity. At that point, shipping terms, charges and conditions should be negotiated with the end-user. These Participating Entities must be notified in advance of any possible shipping charges and mutually agreed to in writing before any purchase or lease is allowed.

The Contractor(s) shall furnish equipment within twenty (20) business days after receipt of order, or a delivery time mutually agreed upon, in writing, between the Participating Entity and the Contractor. The Contractor shall notify the Participating Entity in advance of delivery of equipment so that the Participating Entity can make necessary arrangements. Delivery of start-up supplies shall be made upon or before delivery of equipment. Delivery shall be made in accordance with instructions (time and quantities ordered) from the

Participating Entity as detailed on the Purchase Order. All deliveries shall be accompanied with a Bill of Lading containing the Purchase Order number, the items ordered, the Master Agreement numbers, (both the Master Agreement number and the Participating Entities number) pricing and any special instructions. If there is a discrepancy between the Purchase Order and what is listed on the Master Agreement, it is the Contractor's obligation to seek clarification from the Participating Entity.

All deliveries and installation work shall be performed during regular working hours, defined as 7:00 A.M. to 6:00 P.M. Monday through Friday. Changes may be granted with written approval of the Participating Entity. Any delivery required to be performed outside regular working hours or on Saturdays, Sundays or legal holidays, as may be reasonably required consistent with contractual obligations, and if agreeable to both the Contractor and the Participating Entity, shall be agreed to in writing by both parties.

The Contractor shall be responsible for the delivery of equipment in first class condition at the point of assembly, and in accordance with good commercial practices. The Contractor shall also be responsible for the removing of all debris associated with the purchase from the premises.

- Packing for shipment shall be provided to adequately protect the product and ensure safe shipment.
- Shipping cases shall be marked to indicate the name of the Contractor/Manufacturer's name and address of receiving Participating Entity, Purchase Order number, and Contract number (both the Master Agreement number and the Participating Entities number).

Participating Entities are authorized to order and the Contractor is authorized to ship only those items approved and awarded under the Master Agreement. If any items other than those awarded in the applicable Master Agreement and not eliminated in the PA negotiation process have been ordered and delivered, the Participating Entity shall take any steps necessary to have the items returned to the Contractor. Contractor shall issue full credit upon return of item(s). Violation may result in administrative actions including, but not be limited to termination of the Participating Addendum or the Master Agreement.

3.4 Training & Support Services

- 3.4.1 Upon delivery and installation of specified equipment, the Contractor shall provide training to personnel designated by the Participating Entity. Operational Training must be provided to the designated personnel until the personnel are able to operate the

equipment independently. The amount of training is determined by the complexity of the equipment purchased, rented or leased by the Participating Entity. Installed product and system training shall be included in the price. Contractor shall provide additional training at the Participating Entity's request throughout the life of the equipment. All training will be performed on the Participating Entity's sites, via remote or electronic delivery. Site required training will be at no additional charge if the equipment is either under warranty or an active maintenance plan. Upon the mutual agreement of both parties, additional training outside of initial installation will be at the participating entity's expense. Contractor will be responsible for the cost of all travel, lodging and food; no charges will be passed on to the Participating Entity.

The Contractor must agree to maintain a toll-free technical support telephone line. The telephone line shall be accessible to Participating Entity personnel who need to obtain competent technical assistance regarding the installation or operation of the Contractor's equipment. The toll-free support line shall be available during regular working hours, defined as 7:00 A.M. to 6:00 P.M. local time Monday through Friday.

3.5 Instruction Manuals

- 3.5.1 Instruction manuals shall be included at no cost for each piece of equipment that is purchased or rented. The instruction manual shall contain, but not be limited to:
- Glossary
 - A section defining the capabilities of the equipment (specifications)
 - A general section describing the technical operation of the equipment
 - A section describing the installation and use criteria of the equipment
 - A section on the primary points of contacts for sales, training and maintenance/service
 - All manuals and instruction shall be in the English language

3.6 Technology Advancements

New equipment and technologies may be considered for the possible implementation as long as they are in consonance with USPS rules and guidelines. New equipment and technologies may be offered to the Lead State, twice annually for review and approval. New products are added at the discretion of the Lead State.

3.7 Software purchases or subscriptions

Software acquired under this Master Agreement shall be specific to the needs of mail operations. Purchase order shall reference a manufacturer's most recent release or version of the product unless the Participating Entity specifically requests in writing a different version. As a minimum, software licenses shall provide license rights as prescribed in section 20 of the NASPO ValuePoint Master Agreement Terms and Conditions in Section 6 of this RFP. Software rights other than as proposed shall be negotiated and agreed to by the Participating Entity as defined in the Participating Addendum.

- 3.7.1 In addition to the services directly associated with the receipt of product under this Scope, the Contractor(s) will provide services related to the selection, purchase and management of distributed software, these services include, but are not limited to:
 - 3.7.1.1 Assemble, Production Equipment Only
 - 3.7.1.2 Software Installation/Integration
 - 3.7.1.3 Design, Production Equipment only
 - 3.7.1.4 Maintenance, Annual and Time and Material
 - 3.7.1.5 Legacy Maintenance
 - 3.7.1.6 Lease/Rental/Purchase Options

3.8. Equipment Performance

- 3.8.1 Equipment at each individual location shall maintain, at all times a 95% or better uptime. Downtime shall be computed from the time the Contractor representative is notified of equipment failure until the equipment is fully operational. Equipment that does not meet the performance standard of 95% for a two (2) consecutive month period or for three (3) months in a rolling twelve (12) month period shall be replaced by the Contractor with equal or better equipment. It is understood and accepted that equipment failure may not be attributed to the use of recycled paper and/or recycled/remanufactured supplies, as long as those products meet the specifications set by the USPS.

- 3.8.2 *Repair or Replacement of Unsatisfactory Equipment.*

The Contractor shall grant a credit for any equipment which fails to perform at the effectiveness level defined in section 3.8.1. The credit shall be equivalent to the percentage of down time experienced within that month.

The Contractor may elect to replace a defective component in Production Equipment. The Participating Entity shall notify the Contractor in writing if the repair does not resolve the issue. This written notification will act as a cure letter allowing fifteen (15) days to have resolution plan in place.

During the warranty period, unsatisfactory equipment performance will require an even exchange of equipment of equal or greater performance at no additional cost.

After the warranty period, the credit value shall be the amount paid at the time of purchase.

If equipment or software is not functional after 60 days of delivery, the Purchasing Entity may return for full refund or cancel any rental or lease agreement with no fees or charges of any kind.

3.9. Maintenance on Purchased Equipment

3.9.1 This Master Agreement recognizes two (2) categories of maintenance, Preventive maintenance and Repair Service which is covered by the Service Level Agreement. The Contractor must have the resources, distribution capabilities, inventory of parts, consumable supplies, and staff to meet the requirements of the Master Agreement. Contractor or Contractor's Authorized Dealers/Partners shall maintain replacement parts to ensure minimum downtime. Pricing shall include all maintenance including, but not limited to, all parts, labor and time, and preventative maintenance services at the levels specified for each piece of equipment. The Contractor must offer a full service maintenance contract for all equipment placed. However, the Participating Entity shall have the option of not entering into a maintenance/service contract on purchased equipment, but choose to utilize the Time and Materials option. On-site service shall be available on an immediate need service call basis. Preventive scheduled maintenance is based on the equipment requirements by the Manufacturer. These shall include, cleaning, lubrication, parts replacement and necessary adjustments. Maintenance on any equipment purchased under the Master Agreement must be available for five years.

- Contractor /Authorized Dealer shall provide and maintain a toll-free number, an email address and a fax number for Maintenance and Repair Service.

3.9.2 If a Contractor is called due to non-performance of a system, and the Contractor arrives and determines that the issue is with an excluded item and not their product, they will notify the Purchasing Entity. If the equipment is under a maintenance agreement or in the initial one-year warranty time frame, there will be no cost to the Purchasing Entity for the diagnostic call. If the equipment is not under warranty or a maintenance plan the Contractor may charge their hourly contracted rate.

3.10 Service Level Agreements

3.10.1 All Service Level Agreements shall meet the following requirements:

3.10.1.1 Two (2) hour response time (acknowledgement) to all written or oral notices of a service requirement due to

- an equipment stoppage or malfunction.
- 3.10.12 A factory trained service technician, shall be on site before close business or within 4 hours at the start of the next business day.
- 3.10.13 Any Purchasing Entities that require a 24hr/7 days per week maintenance agreement will be negotiated during the PA process.
- 3.10.14 All parts that require maintenance by a service technician are to be included and considered part of the service repair plan. Failed/defective parts shall be replaced at no additional charge to the Participating Entity.
- 3.10.15 Consumable supplies shall be billed separately.
- 3.10.16 If the equipment includes licensed software, the Contractor shall provide software support.
- 3.10.17 Contractor shall maintain a service log for each piece of equipment at each location. Service log shall be available for Participating entity to review.
- 3.10.18 The Contractor shall supply loaner equipment at equal or greater functionality, at no additional charge, for any inoperable equipment exceeding three (3) business days from time of diagnosis. The Contractor may offer, in lieu of loaner equipment, to provide production or alternative services during the period of repair. This shall be mutually agreed upon in writing beforehand.

3.11 Legacy Maintenance

- 3.11.1 The Contractor shall provide maintenance on legacy devices already sold to a Participating Entity. Pricing will be provided on an Individual Case Basis (ICB), through a quote process.
- 3.11.2 The Contractor must have the resources, distribution capabilities, inventory of parts, consumable supplies and staff to meet the requirements of any Master Agreement. Legacy maintenance pricing shall include but not be limited to all parts, labor and time at the levels specified for each piece of equipment that has previously been purchased from the Manufacturer. The Participating Entity shall have the option of not entering into a maintenance/service contract on purchased equipment, but choose to utilize the Time and Materials option. On-site service is to be available on both an immediate need service call basis, and as needed for preventive maintenance. Preventive maintenance shall be based on the needs of the individual equipment as determined by the manufacturer. This shall include cleaning, lubrication, necessary adjustments, and replacement of unserviceable parts. Maintenance shall be available for equipment that is up to 10 years old from date of purchase.

3.12 Design and Software Consulting Services

Design layout services must be provided at no cost by the Contractor, with the exception of production environment equipment and software consulting services. The total number of hours/days required for services must be agreed to in writing before any design services or software consulting services are initiated. The Contractor shall only charge for actuals costs incurred.

3.13 Installation/Integration

- 3.13.1 All equipment prices shall include installation, with the exception of integrating software solutions and Production Equipment. Contractor may charge the contracted rate for integrating software and Production equipment installation. The total number of hours/days needed shall be agreed to, in writing, before any Installation or, Integration services may be initiated. The Contractor shall charge only for actual costs incurred.
- 3.13.2 If a Contractor needs to utilize special Rigging (e.g. a crane) where the Participating Entity does not have an elevator accessible for moving the equipment, they may charge the hourly Installation /Integration rate. However, all "rigging" charges shall be mutually agreed to, in writing, before work begins.
- 3.13.3 Contractor shall affix a label or a decal to the equipment at the time of installation showing warranty period by dates, and the name, address, and telephone number of the Contractor responsible for warranty service of the equipment.
- 3.13.4 The Contractor and the participating entity shall, prior to purchase, review the installation location to ensure the proposed location meets the manufacturer's installation criteria. If special installation is required, the Contractor and Participating Entity shall agree in writing, to the total cost of the installation based on the hourly/daily rates provided within the Master Agreement. Should the proposed installation location not meet established installation criteria, the Contractor and the Participating Entity may attempt to locate an alternate mutually agreeable location for the equipment.

3.14 Software Maintenance.

Maintenance shall be available for all software licenses purchased. Software maintenance shall include all software updates, patches and new releases/versions and shall be available to all Participating Entities. It is the Contractor's responsibility to communicate all updates, patches, and new releases/versions to all end users. No additional fee shall be charged for installation of the upgrades. The Contractor shall be responsible for Postage Scale software licensing.

3.15 Equipment Leasing.

Participating Entities may enter into lease agreements for the products covered in the Master Agreement. Responders who wish to participate in lease agreements with these individual states/entities must submit copies of all of their lease agreements with their response to this RFP. The lease agreements will not be reviewed or evaluated as part of the RFP evaluation process. The agreements will simply be made available to any state or entity who wishes to negotiate a lease agreement with a Contractor. Any additional Terms and Conditions submitted that are specifically for Equipment Leasing will not become part of the Master Agreement, but the negotiated Lease T&C's will be made part of the PA.

3.16 Equipment Rental.

Individual Participating States and Participating Entities may enter into rental agreements for the products covered in the Master Agreements resulting from the RFP, if they have the legal authority to enter into these types of agreements. Responders who wish to participate in rental agreements with these individual Participating Entities must submit copies of all of their pertinent rental agreements with their responses to this RFP. No additional Terms and Conditions shall apply to any rental agreements. The rental agreements will not be reviewed or evaluated as part of the evaluation process. The agreements will simply be made available to any state or entity who wishes to negotiate a rental agreement with a Contractor. Any additional Terms and Conditions submitted that are specifically for Equipment Rental will not become part of the Master Agreement, but the negotiated Rental T&C's will be made part of the PA.

3.17 Customer Service and Representation

- 3.17.1 *Dedicated Representation and Timely Response.* Contractor shall provide a dedicated representative for each Participating Entity. The Contractor shall submit a list of all Subcontractors by State. The list shall include the name of the dealer, the contact name, title, phone number, physical address, and email address. The Participating Entity shall have sole discretion as to which of the Subcontractors they choose to utilize. The Representative will provide an individual for quote assistance, equipment, services and support recommendations, track and report on equipment lease/rental renewal deadlines, and serve as a contact point for the Participating Entity. Contractor and Authorized Dealers must commit to returning phone calls or responding to emails within two business days.
- 3.17.2 *Problem Escalation.* Contractor must provide an incident escalation path for each Participating Entity, providing on that Participating Entity's website, the name, contact information, and role of individuals to whom problems should be escalated if the problems are not resolved by primary contact with both the Contractor and Authorized Dealer/Partner.
- 3.17.3 *Contract Reviews.* The Contractor shall attend an annual meeting with Lead State Contract Administrator and sourcing team to review

usage and discuss any issues that are occurring, if requested. The Contractor shall meet more often if the Lead State Contract Administrator deems necessary. The Contractor shall conduct a customer satisfaction survey and detailed issues encountered during the previous six-month term. The Contractor shall be prepared to discuss overall effectiveness of contract, total sales, potential cost savings opportunities when could be passed through to the Participating Entities. In a renewal year, the annual review will take place prior to contract extensions. The Lead State Contractor Administrator shall schedule the meeting with the Contactor.

3.18 Price

Pricing shall be a discount off of MSRP list price, with the following exceptions:

1. Maintenance shall be priced based on a Time and Material basis (hourly rate), Design (For Production Equipment only),
2. Installation (Production Equipment only), and Software Consulting Services shall be provided on an hourly/daily rate basis.

Contractor shall submit catalog within 15 days of notice of award. Catalog will include MSRP prices, SKU#, and final contract price. Contractor may propose new products within the category on an annual basis; approval will be at the discretion of the Lead State.

Individual Participating Addendum (PA) may use the Master Agreement pricing as a base and may negotiate an adjusted rate. Any negotiated PA rates, exclusive of taxes or any individual state's administrative fee, shall not exceed the Master Agreement rates. As requested by Purchasing Entity, for example on a high volume single order, Contractor may negotiate to reduce cost for the Participating Entity. Firm individual order quotes shall be provided to Purchasing Entity prior to order submittal. All quotes for purchase, rental or lease shall contain enough detail to easily validate pricing contained within the Master Agreement.

- 3.18.1 *Telephone or Email Quote Support.* Contractor/Authorized Dealer shall accept requests for quotes by telephone, fax, and email. Contractor /Authorized Dealer shall provide and maintain a toll-free number for Purchasing Entity to use. Contractor shall provide an email address for receipt of requests for price quotes. The Contractor must provide written quotes by fax, email or online as requested by the Participating Entity.
- 3.18.2 *Timely Quotes.* Contractor/Authorized Dealer agrees to provide quotes in a timely fashion. Expected response should be within 24 hours but no more than three business days after receiving all of the pertinent information.
- 3.18.3 *Guaranteed 90 Day Quote.* Contractor is required to honor all quotes for 90 calendar days.

- 3.18.4 *Sales Promotion.* The Contractor may conduct sales promotions involving specific products for specified time periods. The promotion should include: the product, the promotional price as compared to the original price and the start and end dates of the sales promotion. The contractor shall maintain a record of all sales promotions and make it available upon request.
- 3.18.5 *Extra-contractual Products and Services Prohibited.* Products and services not awarded in this contract are prohibited from being offered.

3.19 Product Categories

Postage Meter Rental (to include Legacy Postage Meters)

- Digital postage meter must have display that provides date, piece-count, postage used, and postage unused.
- Must be refillable by phone and/or electronically that may be placed on a master account or paid by a purchase card.
- Must imprint postage from \$0.01 to \$99.99.
- No administrative fees for postage meter refills.
- Rental renewal available annually.
- No automatic renewals shall be allowed on this contract.
- No penalties for early rental termination.

Mailing Systems, Ultra Low Volume

- Digital or IBI (Information Based Indicia) Operation to conform with all USPS® requirements.
- Manual Feed.
- Must meter, date envelopes.
- Handles mail envelopes from 3½" x 5" to 12" x 15".
- Interfaces with postage scales.
- Must include locking key or security feature.
- Must imprint postage from \$0.01 to \$99.99.
- Must have replaceable ink cartridge.
- Must have wet or dry tape system for oversize packages.

Mailing Equipment, Mailing Systems, Low Volume

- Digital or IBI (Information Based Indicia) Operation to conform with all USPS® requirements.
- Minimum feed speed of 30 pieces/minute.
- Must meter, date, and seal envelopes.
- Handles standard mail envelopes from 3½" x 5" to 12" x 15".
- Interfaces with postage scales.
- Must include locking key or security feature.

- Must imprint postage from \$0.01 to \$99.99.
- Must have replaceable ink cartridge.
- Must have wet or dry tape system for oversize packages.

Mailing Equipment. Mailing Systems. Medium Volume

- Digital or IBI (Information Based Indicia) Operation to conform with USPS® requirements.
- Minimum feed speed of 45 pieces/minute.
- Must meter, date, and seal envelopes.
- Handles letter mail and large envelopes up to 3/8" thick and 7-1/2" wide.
- Interfaces with postage scales up to 100 lbs.
- Includes tape dispenser for parcel.
- Must imprint postage from \$0.01 to \$99.99.
- Must include locking key or security feature.
- Must have replaceable ink cartridge.
- To include water reservoir with water level indicator.
- Must have sealed and non-sealed modes.

Mailing Systems. High Volume

- Digital or IBI (Information Based Indicia) Operation to conform with USPS® requirements.
- Minimum feed speed of 200 pieces/minute.
- Must meter, date, and seal envelopes.
- Handles letter mail and large envelopes from 3"x 5" to 13" x 13".
- Interfaces with postage scales up to 100lbs.
- Includes Tape Dispenser for parcel.
- Must imprint postage from \$0.01 to \$99.99.
- Must include locking key or security feature.
- Must have replaceable ink cartridge.
- To include water reservoir with water level indicator.
- Must have sealed and non-sealed modes.

Mailing System. Production

- Digital or IBI Operation to conform with USPS® requirements.
- Minimum feed speed of 300+ pieces/minute.
- Must meter, date, and seal envelopes.
- Handles letter mail and large envelopes from 3"x 5" to 13" x 13".
- Interfaces with postage scales up to 100 lbs.
- Includes Tape Dispenser for parcel.
- Must imprint postage from \$0.01 to \$99.99.
- Must include locking key or security feature.
- Must have replaceable ink cartridge.
- To include water reservoir with water level indicator.
- Must have sealed and non-sealed modes.

Integrated Postal Scales

- Capable of Interfacing with Postage Meter.
- Includes variety of rates including: Standard, First Class, Priority Mail, Certified Mail, Return Receipt Registered, C.O.D., Insured, Registered, Bulk Rates, etc.
- Includes keyboard graphics, operator prompts and menu selections.
- Special Carrier Rates.
- Capable of weighing to a 32nd of an oz., displaying in increments of 0.5 oz.
- Must electronically set postage meter by the touch of one button.
- Must include postal rate changes at no additional cost throughout the lease or maintenance contract.

Letter Openers. Low Volume

- Includes Feeder and Stacker, Variable Trim Control.
- Processing speed up to 10,000 pieces per hour Minimum.
- Self-Sharpener trim blade adjusts to allow for narrow or wide cut.
- Includes Tray that collects 80 #10 opened envelopes and trimmings

Letter Openers. High Volume

- Includes Feeder and Stacker, Variable Trim Control.
- Processing speed over 20,000 pieces per hour Minimum.
- Self-Sharpener trim blade adjusts to allow for narrow or wide cut.
- Includes Tray that collects 150 opened envelopes and trimmings.

Letter Folders. Low Volume

- Automatic.
- Folds up to 10,000 sheets per hour minimum.
- Completes Standard or Custom folds. •
- Handles at a minimum paper from 3-1/8" x 4" x 9-1/2" x 14".

Letter Folders. High Volume

- Automatic.
- Folds more than 20,000 sheets per hour minimum.
- Completes Standard or Custom folds.
- Handles at a minimum paper from 3-1/8" x 4" x 12" x 18".
- Able to process Multiple Folds.

Inserters. Production

- Processes up to 5,500 sheets per hour minimum.
- Feeds, collates, folds, and, inserts material into envelopes.
- Jobs can be pre-programmed.

Folder/Inserters, Low volume

- Automatic.
- Completes Standard or Custom folds.
- Handles paper from 3-1/8" x 4" x 9-1/2" x 14".
- Processes up to 1,500 sheets per hour minimum.
- Feeds, collates, folds, and, inserts material into envelopes.
- Jobs can be pre-programmed.

Folders/Inserters, Medium Volume

- Automatic.
- Completes Standard or Custom folds.
- Handles paper from 3-1/8" x 4" x 9-1/2" x 14".
- Processes up from 1501 – 4,999 sheets per hour minimum.
- Feeds, collates, folds, and, inserts material into envelopes.
- Jobs can be pre-programmed.

Folders/Inserters, High Volume

- Automatic.
- Completes Standard or Custom folds.
- Handles paper from 3-1/8" x 4" x 9-1/2" x 14".
- Processes up to 5,000 – 9,999 sheets per hour minimum.
- Feeds, collates, folds, and, inserts material into envelopes.
- Jobs can be pre-programmed.

Folders/Inserters, Production

- Automatic.
- Completes Standard or Custom folds.
- Handles paper from 3-1/8" x 4" x 9-1/2" x 14".
- Processes over 10,000 sheets per hour minimum.
- Feeds, collates, folds, and, inserts material into envelopes.
- Jobs can be pre-programmed.

Envelope Mail Labeler, Low Volume

- Label Speed: up to 5,000 # 10 envelopes per hour.
- Applies permanent (peel off) labels ranging in size from 1" to 4" high and maximum backing strip of 6".
- Adjustable label positioning from side-to-side and top-to-bottom of document.
- Motor driven take-up reel for label backing and control for adjusting for different types of labels and backing.
- Includes digital counter.

Envelope Mail Labeler, Medium Volume

- Label Speed: up to 10,000 # 10 envelopes per hour.
- Applies permanent (peel off) labels ranging in size from 1" to 4" high and maximum backing strip of 6".
- Adjustable label positioning from side-to-side and top-to-bottom of document.

- Motor driven take-up reel for label backing and control for adjusting for different types of labels and backing.
- Includes digital counter.

Envelope Mail Labeler, High Volume

- Label Speed: up to 15,000 # 10 envelopes per hour.
- Applies permanent (peel off) labels ranging in size from 1" to 4" high and maximum backing strip of 6".
- Adjustable label positioning from side-to-side and top-to-bottom of document.
- Motor driven take-up reel for label backing and control for adjusting for different types of labels and backing.
- Includes digital counter.

Envelope Mail Labeler, Production

- Label Speed: up to 25,000 # 10 envelopes per hour.
- Applies permanent (peel off) labels ranging in size from 1" to 4" high and maximum backing strip of 6".
- Adjustable label positioning from side-to-side and top-to-bottom of document.
- Motor driven take-up reel for label backing and control for adjusting for different types of labels and backing.
- Includes digital counter.

Envelope Addressing System, Ink Jet, Low Volume

- Label Speed: up to 2,500 # 10 envelopes per hour.
- Applies address information directly to envelopes.
- Adjustable printing positioning from side-to-side and top-to-bottom of document.
- Adjustable print resolution.
- Scalable fonts.
- Interface with Windows based software.
- Includes digital counter.

Envelope Addressing System, Ink Jet, Medium Volume

- Label Speed: up to 5,000 # 10 envelopes per hour.
- Applies address information directly to envelopes.
- Adjustable printing positioning from side-to-side and top-to-bottom of document.
- Adjustable print resolution.
- Interface with Windows based software.
- Includes digital counter.

Envelope Addressing System, Ink Jet, High Volume

- Label Speed: up to 24,999 # 10 envelopes per hour.
- Applies address information directly to envelopes.
- Adjustable printing positioning from side-to-side and top-to-bottom of document.

- Adjustable print resolution.
- Multiple print heads.
- Movable print heads.
- Print USPS Bar Codes.
- Scalable fonts.
- Interface with Windows based software.
- Includes digital counter.

Envelope Addressing System, Ink Jet, Production

- Label Speed: over 25,000 # 10 envelopes per hour.
- Applies address information directly to envelopes.
- Adjustable printing positioning from side-to-side and top-to-bottom of document.
- Adjustable print resolution.
- Multiple print heads.
- Movable print heads.
- Scalable fonts.
- Print USPS Bar Codes.
- Interface with Windows based software.
- Includes digital counter.

Tabbers, Low Volume

- Complies with all USPS® regulations.
- Single-tab speeds up to 15,000/Hr.
- Multiple tabbing options (paper, clear translucent with or without perforation etc.).
- Easy Programming and Set up.
- Automatic size adjusting (accepts various tab sizes).
- Accepts various types and sizes of media.

Tabbers, Medium Volume

- Complies with all USPS® regulations.
- Single-tab speeds from 15,001 - 22,000/Hr.
- Multiple tabbing options (paper, clear translucent with or without perforation etc.).
- Easy Programming and Set up.
- Automatic size adjusting (accepts various tab sizes).
- Accepts various types and sizes of media.

Tabbers, High Volume

- Complies with all USPS® regulations.
- Single-tab speeds greater than 22,001/Hr. – 50,000/Hr.
- Multiple tabbing options (paper, clear translucent with or without perforation etc.).
- Easy Programming and Set up.
- Accepts various types and sizes of media.

Tabbers. Production

- Complies with all USPS® regulations.
- Single-tab speeds greater than 50,000/Hr.
- Multiple tabbing options (paper, clear translucent with or without perforation etc.).
- Easy Programming and Set up.
- Accepts various types and sizes of media.

Check Imprinting/Endorsing

- Minimum monthly volume of 25,000.
- Utilize both cut sheet and continuous style documents.
- Able to provide a variety of options with regards to signatures, date stamps, seals and logos on various locations on the document.
- Counters that can be reset and non-reset for audit purposes.
- Offers both tri-color and ultraviolet ink roll options.

Pressure Sealing. Production

- Creates a single piece mailer from a full range of stock or custom forms.
- Creates a single piece mailer with a continuous seal formed to assure security and confidentiality.
- Must be able to detect when “double documents” are processed.
- Must be able to detect document jams during production.
- Shall have emergency shut off/safety devise.

Bursting Equipment. Production

- Able to burst cut sheet.
- Able to burst at the perforation.
- Stack sequentially and continuous multipart documents.
- Burst at the horizontal perforations.
- Burst various locations of perforations.

Pre-sorting Equipment. Production

- Minimum monthly volume of 100,000.
- Ability to sort various sizes of envelopes, flats and packages.
- Multiple Station.
- Various rates of speed.
- Ability to process the entire range of USPS.

Extractors

- Processes up to 3000 pieces per hour.
- One, Two, or, Three Sided Opening.
- Includes counting and monitoring system that counts pieces processed.
- Capable of processing various sizes of intermixed mail up to and including #11 envelopes, heights to 5-1/4”.

Mailing Furniture (specific to a category)

- Mailroom furniture shall be appropriate for the mailroom category being it is being offered in.
- Mailroom work tables, pedestals, bins etc. must be constructed of wood, steel or plastic bases with steel, laminate or wood tops that can support the daily use and weight of mailroom product and equipment.
- Only furniture specifically related to the category/group of equipment may be purchased under this category.

Mailing Furniture (general)

- Mailroom furniture shall not be specific to a piece of equipment or a category/group.
- Mailroom free standing mail sorter tables, case works, mail carts etc. must be constructed of wood, steel or plastic bases with steel, laminate or wood tops that can support the dialing use and weight of mailroom activity.

Accessories

- Mailroom accessories must be appropriate for a mailroom operation.
- All accessories related to equipment configurations must be identified in the equipment catalogs with the associated percentage % discount(s) off the manufacturer's suggested retail price.

Software, License and Subscription

- Commercial off-the-shelf (COTS) and customized mailroom related software utilized by mailing equipment (e.g. tracking software or accounting software) and purchased/leased on either a monthly or annual basis.
- All software must be specifically utilized only for mailing equipment operations.
- Includes licensing, software maintenance, technical support and updates.
- All installations will be performed by the Contracted Supplier.
- Updates shall be performed by Contracted Supplier or user.

Software Integration

- Consulting services provided by Contractor that includes but not limited to the process of bringing together applications into one system to ensure the applications function together as a whole for mailing room operations functionality.

Training

- *Additional* training services as specified in Section 3.4.1.

Supplies /Consumables

- All Supplies/Consumables needed to operate the mailing device or equipment.
- Regular paper is not included in this category.
- Labels for addressing and other mailroom purposes are included.

Design, Production Only

- Billable only for Production equipment.
- Total hours/days with total fee will be agreed to in writing from both parties before any work will begin.
- All other Design work is included in the cost of the mailing equipment.

Assembly/Installation, Production Only

- Billable only for Production equipment.
- Total hours/days with total fee will be agreed to in writing from both parties before any work will begin.
- All other Installation work is included in the cost of the mailing equipment.

Equipment Leasing

- See section 3.15.

Equipment Rental

- See section 3.16.

Equipment Relocations Services

- Equipment Relocation Services include: dismantling, packing, transporting and re-installing equipment at the Client Agency's request. No additional charges shall be incurred for fuel or tolls. Awarded contractors may charge for device moves. Such charges must be in the format listed below according to the distance from the original placement:

Move Zone	Distance from the Original Device Placement	Allowable Charge Format
Zone 1	100 Yards or less; or within the same Building	No Charge Allowed
Zone 2	Between Zone 1 and 50 miles	Flat Fee
Zone 3	Outside of Zone 2	Per mile fee

Section 4: NASPO ValuePoint Master Agreement Statement of Compliance

4.1. NASPO ValuePoint Master Agreement(s) resulting from this RFP will constitute the final agreement except for negotiated terms and conditions specific to a Participating Entity's Participating Addendum.

The Master Agreement will include, but not be limited to, the NASPO ValuePoint Standard Terms and Conditions in Section 6 and Lead State specific terms and conditions required to execute a master agreement, the statement of work, Section 3 and selected portions of the Offeror's Proposal.

This section highlights particular terms and conditions of NASPO ValuePoint Master Agreement Terms and Conditions, although Offerors will be bound to all the terms and conditions when executing a Master Agreement as shown in section 6. Offerors must include a statement in their Proposal that they have read and understand all of the terms and conditions as shown in the Master Agreement (section 6).

4.1.a Insurance

To be eligible for award, the Offeror agrees to acquire insurance from an insurance carrier or carriers licensed to conduct business in each Participating Entity's state at the prescribed levels set forth in Section 21 of the NASPO ValuePoint Master Agreement Terms and Conditions. Describe your insurance or plans to obtain insurance satisfying the requirements in Section 21.

4.1.b NASPO ValuePoint Administrative Fee and Reporting Requirements

To be eligible for award, the Offeror agrees to pay a NASPO ValuePoint administrative fee as specified in Paragraph 6 of Section 6 of the NASPO ValuePoint Master Agreement Terms and Conditions. Moreover, specific summary and detailed usage reporting requirements are prescribed in paragraph 7 of NASPO ValuePoint Master Agreement Terms and Conditions.

Offerors shall identify the person responsible for providing the mandatory usage reports. This information must be kept current during the contract period. Contractor will be required to provide reporting contact within 15 days of Master Agreement execution.

4.2 Lead State Terms and Conditions.

Refer to Section 7 for the Lead State Special Terms and Conditions that apply to this solicitation and the resulting Master Agreements

Section 5: Price and Cost Proposal

Cost proposal must be submitted to the Lead State as a separate document in Offerors Proposal. **Do not embed cost proposal in the technical proposal response.**

Offeror shall provide detailed costs for all costs associated with the responsibilities and related services, per Attachment 4.

Cost for the NASPO ValuePoint Master Agreements shall be based on the following:

Offeror must submit cost, prices and rates as required by (Pricing and Pricing Scenario Workbooks attached in APP within the Attachments Tab), Cost Sheets. Prices and rates shall include all anticipated charges, including but not limited to, freight and delivery, cost of materials and product, travel expenses, transaction fees, overhead, profits, and other costs or expenses incidental to the Offeror's performance.

The Lead State is exempt from federal excise taxes and no payment will be made for any taxes levied on the Offeror's or any Subcontractor's employee's wages. The Lead State will pay for any applicable Lead State or local sales or use taxes on the products provided or the services rendered. If required by Lead State, Taxes shall be included as a separate line item on an Offeror's invoice. The tax rules with respect to other Participating Entities may vary and are expected to be addressed in the Participating Amendments.



Section 6: NASPO VALUEPOINT MASTER AGREEMENT TERMS AND CONDITIONS

I. Definitions

- 1.1 **Acceptance** means acceptance of goods and services as set forth in Section IX of this Master Agreement.
- 1.2 **Contractor** means a party to this Master Agreement, whether a person or entity, that delivers goods or performs services under the terms set forth in this Master Agreement.
- 1.3 **Embedded Software** means one or more software applications which permanently reside on a computing device.
- 1.4 **Intellectual Property** means any and all patents, copyrights, service marks, trademarks, trade secrets, trade names, patentable inventions, or other similar proprietary rights, in tangible or intangible form, and all rights, title, and interest therein.
- 1.5 **Lead State** means the State centrally administering any resulting Master Agreement(s) who is a party to this Master Agreement.
- 1.6 **Master Agreement** means the underlying agreement executed by and between the Lead State, acting in cooperation with NASPO ValuePoint, and the Contractor, as now or hereafter amended.
- 1.7 **NASPO ValuePoint** is a division of the National Association of State Procurement Officials ("NASPO"), a 501(c)(3) limited liability company. NASPO ValuePoint facilitates administration of the NASPO cooperative group contracting consortium of state chief procurement officials for the benefit of state departments, institutions, agencies, and political subdivisions and other eligible entities (i.e., colleges, school districts, counties, cities, some nonprofit organizations, etc.) for all states, the District of Columbia, and territories of the United States. NASPO ValuePoint is identified in the Master Agreement as the recipient of reports and may perform contract administration functions relating to collecting and receiving reports, as well as other contract administration functions as assigned by the Lead State.
- 1.8 **Order or Purchase Order** means any purchase order, sales order, contract or other document used by a Purchasing Entity to order the Products.
- 1.9 **Participating Addendum** means a bilateral agreement executed by a Contractor and a Participating Entity incorporating this Master Agreement and any additional Participating Entity-specific language or other requirements (e.g., ordering procedures specific to the Participating Entity, entity-specific terms and conditions, etc.).
- 1.10 **Participating Entity** means a state (as well as the District of Columbia and US territories), city, county, district, other political subdivision of a State, or a nonprofit organization under the laws of some states properly authorized to enter into a Participating Addendum, that has executed a Participating Addendum.
- 1.11 **Participating State** means a state that has executed a Participating Addendum or has indicated an intent to execute a Participating Addendum.
- 1.12 **Product or Products and Services** means any equipment, software (including embedded software), documentation, service, or other deliverable supplied or created by the Contractor pursuant to this Master Agreement. The term Product includes goods and services.

- 1.13 Purchasing Entity** means a state (as well as the District of Columbia and US territories), city, county, district, other political subdivision of a State, or a nonprofit organization under the laws of some states if authorized by a Participating Addendum, that issues a Purchase Order against the Master Agreement and becomes financially committed to the purchase.

II. Term of Master Agreement

- 2.1 Initial Term.** The initial term of this Master Agreement is for one (1) year. The term of this Master Agreement may be amended beyond the initial term for four (4) additional years at the Lead State's discretion and by mutual agreement and upon review of requirements of Participating Entities, current market conditions, and Contractor performance.
- 2.2 Amendment Limitations.** The terms of this Master Agreement will not be waived, altered, modified, supplemented, or amended in any manner whatsoever without prior written agreement of the Lead State and Contractor.
- 2.3 Amendment Term.** The term of the Master Agreement may be amended past the initial term and stated renewal periods for a reasonable period if in the judgment of the Lead State a follow-on competitive procurement will be unavoidably delayed (despite good faith efforts) beyond the planned date of execution of the follow-on master agreement. This subsection will not be deemed to limit the authority of a Lead State under its state law to otherwise negotiate contract extensions.

III. Order of Precedence

- 3.1 Order.** Any Order placed under this Master Agreement will consist of the following documents:
- 3.1.1** A Participating Entity's Participating Addendum ("PA");
 - 3.1.2** NASPO ValuePoint Master Agreement, including all attachments thereto;
 - 3.1.3** A Purchase Order or Scope of Work/Specifications issued against the Master Agreement;
 - 3.1.4** The Solicitation or, if separately executed after award, the Lead State's bilateral agreement that integrates applicable provisions;
 - 3.1.5** Contractor's response to the Solicitation, as revised (if permitted) and accepted by the Lead State.
- 3.2 Conflict.** These documents will be read to be consistent and complementary. Any conflict among these documents will be resolved by giving priority to these documents in the order listed above. Contractor terms and conditions that apply to this Master Agreement are only those that are expressly accepted by the Lead State and must be in writing and attached to this Master Agreement as an Exhibit or Attachment.
- 3.3 Participating Addenda.** Participating Addenda will not be construed to diminish, modify, or otherwise derogate any provisions in this Master Agreement between the Lead State and Contractor. Participating Addenda will not include a term of agreement that exceeds the term of the Master Agreement.

IV. Participants and Scope

- 4.1 Requirement for a Participating Addendum.** Contractor may not deliver Products under this Master Agreement until a Participating Addendum acceptable to the Participating Entity and Contractor is executed.
- 4.2 Applicability of Master Agreement.** NASPO ValuePoint Master Agreement Terms and Conditions are applicable to any Order by a Participating Entity (and other Purchasing Entities covered by their Participating Addendum), except to the extent altered, modified, supplemented

or amended by a Participating Addendum, subject to Section III. For the purposes of illustration and not limitation, this authority may apply to unique delivery and invoicing requirements, confidentiality requirements, defaults on Orders, governing law and venue relating to Orders by a Participating Entity, indemnification, and insurance requirements. Statutory or constitutional requirements relating to availability of funds may require specific language in some Participating Addenda in order to comply with applicable law. The expectation is that these alterations, modifications, supplements, or amendments will be addressed in the Participating Addendum or, with the consent of the Purchasing Entity and Contractor, may be included in the ordering document (e.g., purchase order or contract) used by the Purchasing Entity to place the Order.

- 4.3 Authorized Use.** Use of specific NASPO ValuePoint Master Agreements by state agencies, political subdivisions and other Participating Entities is subject to applicable state law and the approval of the respective State Chief Procurement Official. Issues of interpretation and eligibility for participation are solely within the authority of the respective State Chief Procurement Official.
- 4.4 Obligated Entities.** Obligations under this Master Agreement are limited to those Participating Entities who have signed a Participating Addendum and Purchasing Entities within the scope of those Participating Addenda. States or other entities permitted to participate may use an informal competitive process to determine which Master Agreements to participate in through execution of a Participating Addendum. Participating Entities incur no financial obligations on behalf of other Purchasing Entities.
- 4.5 Notice of Participating Addendum.** Contractor shall email a fully executed PDF copy of each Participating Addendum to pa@naspovaluepoint.org to support documentation of participation and posting in appropriate databases.
- 4.6 Eligibility for a Participating Addendum.** Eligible entities who are not states may under some circumstances sign their own Participating Addendum, subject to the consent of the Chief Procurement Official of the state where the entity is located. Coordinate requests for such participation through NASPO ValuePoint. Any permission to participate through execution of a Participating Addendum is not a determination that procurement authority exists; the entity must ensure that they have the requisite procurement authority to execute a Participating Addendum.
- 4.7 Prohibition on Resale.** Subject to any specific conditions included in the solicitation or Contractor's proposal as accepted by the Lead State, or as explicitly permitted in a Participating Addendum, Purchasing Entities may not resell Products purchased under this Master Agreement. Absent any such condition or explicit permission, this limitation does not prohibit: payments by employees of a Purchasing Entity for Products; sales of Products to the general public as surplus property; and fees associated with inventory transactions with other governmental or nonprofit entities and consistent with a Purchasing Entity's laws and regulations. Any sale or transfer permitted by this subsection must be consistent with license rights granted for use of intellectual property.
- 4.8 Individual Customers.** Except as may otherwise be agreed to by the Purchasing Entity and Contractor, each Purchasing Entity shall follow the terms and conditions of the Master Agreement and applicable Participating Addendum and will have the same rights and responsibilities for their purchases as the Lead State has in the Master Agreement and as the Participating Entity has in the Participating Addendum, including but not limited to any indemnity or right to recover any costs as such right is defined in the Master Agreement and applicable Participating Addendum for their purchases. Each Purchasing Entity will be responsible for its own charges, fees, and liabilities. The Contractor will apply the charges and invoice each Purchasing Entity individually.
- 4.9 Release of Information.** Throughout the duration of this Master Agreement, Contractor must secure from the Lead State prior approval for the release of information that pertains to the

potential work or activities covered by the Master Agreement. This limitation does not preclude publication about the award of the Master Agreement or marketing activities consistent with any proposed and accepted marketing plan.

- 4.10 No Representations.** The Contractor shall not make any representations of NASPO ValuePoint, the Lead State, any Participating Entity, or any Purchasing Entity's opinion or position as to the quality or effectiveness of the services that are the subject of this Master Agreement without prior written consent.

V. NASPO ValuePoint Provisions

- 5.1 Applicability.** NASPO ValuePoint is not a party to the Master Agreement. The terms set forth in Section V are for the benefit of NASPO ValuePoint as a third-party beneficiary of this Master Agreement.

5.2 Administrative Fees

5.2.1 NASPO ValuePoint Fee. Contractor shall pay to NASPO ValuePoint, or its assignee, a NASPO ValuePoint Administrative Fee of one-quarter of one percent (0.25% or 0.0025) no later than sixty (60) days following the end of each calendar quarter. The NASPO ValuePoint Administrative Fee must be submitted quarterly and is based on all sales of products and services under the Master Agreement (less any charges for taxes or shipping). The NASPO ValuePoint Administrative Fee is not negotiable. This fee is to be included as part of the pricing submitted with a vendor's response to the Lead State's solicitation.

5.2.2 State Imposed Fees. Some states may require an additional fee be paid directly to the state on purchases made by Purchasing Entities within that state. For all such requests, the fee rate or amount, payment method and schedule for such reports and payments will be incorporated into the applicable Participating Addendum. Unless agreed to in writing by the state, Contractor may not adjust the Master Agreement pricing to include the state fee for purchases made by Purchasing Entities within the jurisdiction of the state. No such agreement will affect the NASPO ValuePoint Administrative Fee percentage or the prices paid by Purchasing Entities outside the jurisdiction of the state requesting the additional fee.

5.3 NASPO ValuePoint Summary and Detailed Usage Reports

5.3.1 Summary Sales Data. The Contractor shall submit quarterly sales reports directly to NASPO ValuePoint using the NASPO ValuePoint Quarterly Sales/Administrative Fee Reporting Tool found at <http://calculator.naspovaluepoint.org>. All sales made under this Master Agreement must be reported as cumulative totals by state. Contractor must submit a report for each quarter, including quarters during which a Contractor has no sales, in which case this will be indicated in the Reporting Tool. Reports must be submitted no later than thirty (30) days following the end of the calendar quarter (as specified in the reporting tool).

5.3.2 Detailed Sales Data. Contractor shall also report detailed sales data by: (1) state; (2) entity/customer type, e.g. local government, higher education, K12, non-profit; (3) Purchasing Entity name; (4) Purchasing Entity bill-to and ship-to locations; (4) Purchasing Entity and Contractor Purchase Order identifier/number(s); (5) Purchase Order Type (e.g. sales order, credit, return, upgrade, determined by industry practices); (6) Purchase Order date; (7) Ship Date; (8) and line item description, including product number if used. The report must be submitted in any form required by the solicitation. Reports are due on a quarterly basis and must be received by the Lead State and NASPO ValuePoint Cooperative Development Team no later than thirty (30) days after the end of the reporting period. Reports must be delivered to the Lead State and to the NASPO ValuePoint Cooperative Development Team electronically through a designated

portal or other method as determined by the Lead State and NASPO ValuePoint. Detailed sales data reports must include sales information for all sales under Participating Addenda executed under this Master Agreement.

5.3.3 Reporting on Personal Use. Reportable sales for the summary sales data report and detailed sales data report includes sales to employees for personal use where authorized by the solicitation and the Participating Addendum. Report data for employees should be limited to ONLY the state and entity ((state and agency, city, county, school district, etc.) under whose authority the employee is purchasing Product for personal use and the amount of sales. No personal identification numbers (*e.g.*, names, addresses, **social security numbers or any other numerical identifier**) may be submitted with any report.

5.3.4 Executive Summary. Contractor shall provide the NASPO ValuePoint Cooperative Development Coordinator with an executive summary each quarter that includes, at a minimum, a list of states with an active Participating Addendum, states that Contractor is in negotiations with and any Participating Addendum roll out or implementation activities and issues. NASPO ValuePoint Cooperative Development Coordinator and Contractor will determine the format and content of the executive summary. The executive summary is due thirty (30) days after the conclusion of each calendar quarter.

5.3.5 Use of Data. Timely submission of these reports is a material requirement of the Master Agreement. The recipient of the reports will have exclusive ownership of the media containing the reports. The Lead State and NASPO ValuePoint shall have a perpetual, irrevocable, non-exclusive, royalty free, transferable right to display, modify, copy, and otherwise use reports, data and information provided under this section.

5.4 NASPO ValuePoint Cooperative Program Marketing, Training, and Performance Review

5.4.1 Staff Education. Contractor shall work cooperatively with NASPO ValuePoint personnel. Contractor shall present plans to NASPO ValuePoint for the education of Contractor's contract administrator(s) and sales/marketing workforce regarding the Master Agreement contract, including the competitive nature of NASPO ValuePoint procurements, the master agreement and participating addendum process, and the manner in which eligible entities can participate in the Master Agreement.

5.4.2 Onboarding Plan. Upon request by NASPO ValuePoint, Contractor shall, as Participating Addendums are executed, provide plans to launch the program for the Participating Entity. Plans will include time frames to launch the agreement and confirmation that the Contractor's website has been updated to properly reflect the scope and terms of the Master Agreement as available to the Participating Entity and eligible Purchasing Entities.

5.4.3 Annual Contract Performance Review. Contractor shall participate in an annual contract performance review with the Lead State and NASPO ValuePoint, which may at the discretion of the Lead State be held in person and which may include a discussion of marketing action plans, target strategies, marketing materials, Contractor reporting, and timeliness of payment of administration fees.

5.4.4 Use of NASPO ValuePoint Logo. The NASPO ValuePoint logos may not be used by Contractor in sales and marketing until a separate logo use agreement is executed with NASPO ValuePoint.

5.4.5 Most Favored Customer. Contractor shall, within thirty (30) days of their effective date, to notify the Lead State and NASPO ValuePoint of any contractual most-favored-customer provisions in third-party contracts or agreements that may affect the promotion of this Master Agreements or whose terms provide for adjustments to future rates or pricing based on rates, pricing in, or Orders from this Master Agreement. Upon request

of the Lead State or NASPO ValuePoint, Contractor shall provide a copy of any such provisions.

- 5.5 Cancellation.** In consultation with NASPO ValuePoint, the Lead State may, in its discretion, cancel the Master Agreement or not exercise an option to renew, when utilization of Contractor's Master Agreement does not warrant further administration of the Master Agreement. The Lead State may also exercise its right to not renew the Master Agreement if vendor fails to record or report revenue for three consecutive quarters, upon 60-calendar day written notice to the Contractor. Cancellation based on nonuse or under-utilization will not occur sooner than [two years] after execution of the Master Agreement. This subsection does not limit the discretionary right of either the Lead State or Contractor to cancel the Master Agreement or terminate for default subject to the terms herein. This subsection also does not limit any right of the Lead State to cancel the Master Agreement under applicable laws.
- 5.6 Canadian Participation.** Subject to the approval of Contractor, any Canadian provincial government or provincially funded entity in Alberta, British Columbia, Manitoba, New Brunswick, Newfoundland and Labrador, Nova Scotia, Ontario, Prince Edward Island, Quebec, or Saskatchewan, and territorial government or territorial government funded entity in the Northwest Territories, Nunavut, or Yukon, including municipalities, universities, community colleges, school boards, health authorities, housing authorities, agencies, boards, commissions, and crown corporations, may be eligible to use Contractor's Master Agreement.
- 5.7 Additional Agreement with NASPO.** Upon request by NASPO ValuePoint, awarded Contractor shall enter into a direct contractual relationship with NASPO ValuePoint related to Contractor's obligations to NASPO ValuePoint under the terms of the Master Agreement, the terms of which shall be the same or similar (and not less favorable) than the terms set forth in the Master Agreement.

VI. Pricing, Payment & Leasing

- 6.1 Pricing.** The prices contained in this Master Agreement or offered under this Master Agreement represent the not-to-exceed price to any Purchasing Entity.
- 6.1.1** All prices and rates must be guaranteed for the initial term of the Master Agreement.
- 6.1.2** Following the initial term of the Master Agreement, any request for a price or rate adjustment must be for an equal guarantee period and must be made at least 90 days prior to the effective date.
- 6.1.3** Requests for a price or rate adjustment must include sufficient documentation supporting the request. Any adjustment or amendment to the Master Agreement will not be effective unless approved in writing by the Lead State.
- 6.1.4** No retroactive adjustments to prices or rates will be allowed.
- 6.2 Payment.** Unless otherwise agreed upon in a Participating Addendum or Order, Payment after Acceptance will be made within thirty (30) days following the date the entire order is delivered or the date a correct invoice is received, whichever is later. After 45 days the Contractor may assess overdue account charges up to a maximum rate of one percent per month on the outstanding balance, unless a different late payment amount is specified in a Participating Addendum or Order, or otherwise prescribed by applicable law. Payments will be remitted in the manner specified in the Participating Addendum or Order. Payments may be made via a purchasing card with no additional charge.
- 6.3 Leasing or Alternative Financing Methods.** The procurement and other applicable laws of some Purchasing Entities may permit the use of leasing or alternative financing methods for the acquisition of Products under this Master Agreement. Where the terms and conditions are not otherwise prescribed in an applicable Participating Addendum, the terms and conditions for

leasing or alternative financing methods are subject to negotiation between the Contractor and Purchasing Entity.

VII. Ordering

- 7.1 Order Numbers.** Master Agreement order and purchase order numbers must be clearly shown on all acknowledgments, packing slips, invoices, and on all correspondence.
- 7.2 Quotes.** Purchasing Entities may define entity-specific or project-specific requirements and informally compete the requirement among companies having a Master Agreement on an "as needed" basis. This procedure may also be used when requirements are aggregated or other firm commitments may be made to achieve reductions in pricing. This procedure may be modified in Participating Addenda and adapted to the Purchasing Entity's rules and policies. The Purchasing Entity may in its sole discretion determine which Master Agreement Contractors should be solicited for a quote. The Purchasing Entity may select the quote that it considers most advantageous, cost, and other factors considered.
- 7.3 Applicable Rules.** Each Purchasing Entity will identify and utilize its own appropriate purchasing procedure and documentation. Contractor is expected to become familiar with the Purchasing Entities' rules, policies, and procedures regarding the ordering of supplies and/or services contemplated by this Master Agreement.
- 7.4 Required Documentation.** Contractor shall not begin work without a valid Purchase Order or other appropriate commitment document under the law of the Purchasing Entity.
- 7.5 Term of Purchase.** Orders may be placed consistent with the terms of this Master Agreement and applicable Participating Addendum during the term of the Master Agreement and Participating Addendum.
- 7.5.1** Orders must be placed pursuant to this Master Agreement prior to the termination date thereof, but may have a delivery date or performance period up to 120 days past the then-current termination date of this Master Agreement.
- 7.5.2** Notwithstanding the previous, Orders must also comply with the terms of the applicable Participating Addendum, which may further restrict the period during which Orders may be placed or delivered.
- 7.5.3** Financial obligations of Purchasing Entities payable after the current applicable fiscal year are contingent upon agency funds for that purpose being appropriated, budgeted, and otherwise made available.
- 7.5.4** Notwithstanding the expiration, cancellation or termination of this Master Agreement, Contractor shall perform in accordance with the terms of any Orders then outstanding at the time of such expiration or termination. Contractor shall not honor any Orders placed after the expiration, cancellation, or termination of this Master Agreement, or in any manner inconsistent with this Master Agreement's terms.
- 7.5.5** Orders for any separate indefinite quantity, task order, or other form of indefinite delivery order arrangement priced against this Master Agreement may not be placed after the expiration or termination of this Master Agreement, notwithstanding the term of any such indefinite delivery order agreement.
- 7.6 Order Form Requirements.** All Orders pursuant to this Master Agreement, at a minimum, must include:
- 7.6.1** The services or supplies being delivered;
- 7.6.2** A shipping address and other delivery requirements, if any;
- 7.6.3** A billing address;

- 7.6.4 Purchasing Entity contact information;
 - 7.6.5 Pricing consistent with this Master Agreement and applicable Participating Addendum and as may be adjusted by agreement of the Purchasing Entity and Contractor;
 - 7.6.6 A not-to-exceed total for the products or services being ordered; and
 - 7.6.7 The Master Agreement number or the applicable Participating Addendum number, provided the Participating Addendum references the Master Agreement number.
- 7.7 **Communication.** All communications concerning administration of Orders placed must be furnished solely to the authorized purchasing agent within the Purchasing Entity's purchasing office, or to such other individual identified in writing in the Order.
- 7.8 **Contract Provisions for Orders Utilizing Federal Funds.** Pursuant to Appendix II to 2 Code of Federal Regulations (CFR) Part 200, Contract Provisions for Non-Federal Entity Contracts Under Federal Awards, Orders funded with federal funds may have additional contractual requirements or certifications that must be satisfied at the time the Order is placed or upon delivery. These federal requirements may be proposed by Participating Entities in Participating Addenda and Purchasing Entities for incorporation in Orders placed under this Master Agreement.

VIII. Shipping and Delivery

- 8.1 **Shipping Terms.** All deliveries will be F.O.B. destination, freight pre-paid, with all transportation and handling charges paid by the Contractor.
- 8.1.1 Notwithstanding the above, responsibility and liability for loss or damage will remain the Contractor's until final inspection and acceptance when responsibility will pass to the Purchasing Entity except as to latent defects, fraud, and Contractor's warranty obligations.
- 8.2 **Minimum Shipping.** The minimum shipment amount, if any, must be contained in the Master Agreement. Any order for less than the specified amount is to be shipped with the freight prepaid and added as a separate item on the invoice. Any portion of an Order to be shipped without transportation charges that is back ordered will be shipped without charge.
- 8.3 **Inside Deliveries.** To the extent applicable, all deliveries will be "Inside Deliveries" as designated by a representative of the Purchasing Entity placing the Order. Inside Delivery refers to a delivery to a location other than a loading dock, front lobby, or reception area. Specific delivery instructions will be noted on the order form or Purchase Order. Costs to repair any damage to the building interior (e.g., scratched walls, damage to the freight elevator, etc.) caused by Contractor or Contractor's carrier will be the responsibility of the Contractor. Immediately upon becoming aware of such damage, Contractor shall notify the Purchasing Entity placing the Order.
- 8.4 **Packaging.** All products must be delivered in the manufacturer's standard package. Costs must include all packing and/or crating charges. Cases must be of durable construction, in good condition, properly labeled and suitable in every respect for storage and handling of contents. Each shipping carton must be marked with the commodity, brand, quantity, item code number and the Purchasing Entity's Purchase Order number.

IX. Inspection and Acceptance

- 9.1 **Laws and Regulations.** Any and all Products offered and furnished must comply fully with all applicable Federal, State, and local laws and regulations.

9.2 Applicability. Unless otherwise specified in the Master Agreement, Participating Addendum, or ordering document, the terms of this Section IX will apply. This section is not intended to limit rights and remedies under the applicable commercial code.

9.3 Inspection. All Products are subject to inspection at reasonable times and places before Acceptance. Contractor shall provide right of access to the Lead State, or to any other authorized agent or official of the Lead State or other Participating or Purchasing Entity, at reasonable times, to monitor and evaluate performance, compliance, and/or quality assurance requirements under this Master Agreement.

9.3.1 Products that do not meet specifications may be rejected. Failure to reject upon receipt, however, does not relieve the contractor of liability for material (nonconformity that substantially impairs value) latent or hidden defects subsequently revealed when goods are put to use.

9.3.2 Acceptance of such goods may be revoked in accordance with the provisions of the applicable commercial code, and the Contractor is liable for any resulting expense incurred by the Purchasing Entity related to the preparation and shipping of Product rejected and returned, or for which Acceptance is revoked.

9.4 Failure to Conform. If any services do not conform to contract requirements, the Purchasing Entity may require the Contractor to perform the services again in conformity with contract requirements, at no increase in Order amount. When defects cannot be corrected by re-performance, the Purchasing Entity may require the Contractor to take necessary action to ensure that future performance conforms to contract requirements and reduce the contract price to reflect the reduced value of services performed.

9.5 Acceptance Testing. Purchasing Entity may establish a process, in keeping with industry standards, to ascertaining whether the Product meets the standard of performance or specifications prior to Acceptance by the Purchasing Entity.

9.5.1 The Acceptance Testing period will be thirty (30) calendar days, unless otherwise specified, starting from the day after the Product is delivered or, if installed by Contractor, the day after the Product is installed and Contractor certifies that the Product is ready for Acceptance Testing.

9.5.2 If the Product does not meet the standard of performance or specifications during the initial period of Acceptance Testing, Purchasing Entity may, at its discretion, continue Acceptance Testing on a day-to-day basis until the standard of performance is met.

9.5.3 Upon rejection, the Contractor will have fifteen (15) calendar days to cure. If after the cure period, the Product still has not met the standard of performance or specifications, the Purchasing Entity may, at its option: (a) declare Contractor to be in breach and terminate the Order; (b) demand replacement Product from Contractor at no additional cost to Purchasing Entity; or, (c) continue the cure period for an additional time period agreed upon by the Purchasing Entity and the Contractor.

9.5.4 Contractor shall pay all costs related to the preparation and shipping of Product returned pursuant to the section.

9.5.5 No Product will be deemed Accepted and no charges will be paid until the standard of performance or specification is met.

X. Warranty

10.1 Applicability. Unless otherwise specified in the Master Agreement, Participating Addendum, or ordering document, the terms of this Section X will apply.

10.2 Warranty. The Contractor warrants for a period of one year from the date of Acceptance that:
(a) the Product performs according to all specific claims that the Contractor made in its response

to the solicitation, (b) the Product is suitable for the ordinary purposes for which such Product is used, (c) the Product is suitable for any special purposes identified in the solicitation or for which the Purchasing Entity has relied on the Contractor's skill or judgment, (d) the Product is designed and manufactured in a commercially reasonable manner, and (e) the Product is free of defects.

- 10.3 Breach of Warranty.** Upon breach of the warranty set forth above, the Contractor will repair or replace (at no charge to the Purchasing Entity) the Product whose nonconformance is discovered and made known to the Contractor. If the repaired and/or replaced Product proves to be inadequate, or fails of its essential purpose, the Contractor will refund the full amount of any payments that have been made.
- 10.4 Rights Reserved.** The rights and remedies of the parties under this warranty are in addition to any other rights and remedies of the parties provided by law or equity, including, without limitation, actual damages, and, as applicable and awarded under the law, to a prevailing party, reasonable attorneys' fees and costs.
- 10.5 Warranty Period Start Date.** The warranty period will begin upon Acceptance, as set forth in Section IX.

XI. Product Title

- 11.1 Conveyance of Title.** Upon Acceptance by the Purchasing Entity, Contractor shall convey to Purchasing Entity title to the Product free and clear of all liens, encumbrances, or other security interests.
- 11.2 Embedded Software.** Transfer of title to the Product must include an irrevocable and perpetual license to use any Embedded Software in the Product. If Purchasing Entity subsequently transfers title of the Product to another entity, Purchasing Entity shall have the right to transfer the license to use the Embedded Software with the transfer of Product title. A subsequent transfer of this software license will be at no additional cost or charge to either Purchasing Entity or Purchasing Entity's transferee.
- 11.3 License of Pre-Existing Intellectual Property.** Contractor grants to the Purchasing Entity a nonexclusive, perpetual, royalty-free, irrevocable, license to use, publish, translate, reproduce, transfer with any sale of tangible media or Product, perform, display, and dispose of the Intellectual Property, and its derivatives, used or delivered under this Master Agreement, but not created under it ("Pre-existing Intellectual Property"). The Contractor shall be responsible for ensuring that this license is consistent with any third-party rights in the Pre-existing Intellectual Property.

XII. Indemnification

- 12.1 General Indemnification.** The Contractor shall defend, indemnify and hold harmless NASPO, NASPO ValuePoint, the Lead State, Participating Entities, and Purchasing Entities, along with their officers and employees, from and against third-party claims, damages or causes of action including reasonable attorneys' fees and related costs for any death, injury, or damage to tangible property arising from any act, error, or omission of the Contractor, its employees or subcontractors or volunteers, at any tier, relating to performance under this Master Agreement.
- 12.2 Intellectual Property Indemnification.** The Contractor shall defend, indemnify and hold harmless NASPO, NASPO ValuePoint, the Lead State, Participating Entities, Purchasing Entities, along with their officers and employees ("Indemnified Party"), from and against claims, damages or causes of action including reasonable attorneys' fees and related costs arising out of the claim that the Product or its use infringes Intellectual Property rights of another person or entity ("Intellectual Property Claim").

- 12.2.1 The Contractor's obligations under this section will not extend to any combination of the Product with any other product, system or method, unless the Product, system or method is:
 - 12.2.1.1 provided by the Contractor or the Contractor's subsidiaries or affiliates;
 - 12.2.1.2 specified by the Contractor to work with the Product;
 - 12.2.1.3 reasonably required to use the Product in its intended manner, and the infringement could not have been avoided by substituting another reasonably available product, system or method capable of performing the same function; or
 - 12.2.1.4 reasonably expected to be used in combination with the Product.
- 12.2.2 The Indemnified Party shall notify the Contractor within a reasonable time after receiving notice of an Intellectual Property Claim. Even if the Indemnified Party fails to provide reasonable notice, the Contractor shall not be relieved from its obligations unless the Contractor can demonstrate that it was prejudiced in defending the Intellectual Property Claim resulting in increased expenses or loss to the Contractor. If the Contractor promptly and reasonably investigates and defends any Intellectual Property Claim, it shall have control over the defense and settlement of the Intellectual Property Claim. However, the Indemnified Party must consent in writing for any money damages or obligations for which it may be responsible.
- 12.2.3 The Indemnified Party shall furnish, at the Contractor's reasonable request and expense, information and assistance necessary for such defense. If the Contractor fails to vigorously pursue the defense or settlement of the Intellectual Property Claim, the Indemnified Party may assume the defense or settlement of the Intellectual Property Claim and the Contractor shall be liable for all costs and expenses, including reasonable attorneys' fees and related costs, incurred by the Indemnified Party in the pursuit of the Intellectual Property Claim.
- 12.2.4 Unless otherwise set forth herein, Section 12.2 is not subject to any limitations of liability in this Master Agreement or in any other document executed in conjunction with this Master Agreement.

XIII. Insurance

- 13.1 **Term.** Contractor shall, during the term of this Master Agreement, maintain in full force and effect, the insurance described in this section. A Participating Entity may negotiate alternative Insurance requirements in their Participating Addendum.
- 13.2 **Class.** Contractor shall acquire such insurance from an insurance carrier or carriers licensed to conduct business in each Participating Entity's state and having a rating of A-, Class VII or better, in the most recently published edition of A.M. Best's Insurance Reports. Failure to buy and maintain the required insurance may result in this Master Agreement's termination or, at a Participating Entity's option, result in termination of its Participating Addendum.
- 13.3 **Coverage.** Coverage must be written on an occurrence basis. The minimum acceptable limits will be as indicated below:
 - 13.3.1 Contractor shall maintain Commercial General Liability insurance covering premises operations, independent contractors, products and completed operations, blanket contractual liability, personal injury (including death), advertising liability, and property damage, with a limit of not less than \$1 million per occurrence and \$2 million general aggregate;
 - 13.3.2 Contractor must comply with any applicable State Workers Compensation or Employers Liability Insurance requirements.

- 13.4 Notice of Cancellation.** Contractor shall pay premiums on all insurance policies. Contractor shall provide notice to a Participating Entity who is a state within five (5) business days after Contractor is first aware of expiration, cancellation or nonrenewal of such policy or is first aware that cancellation is threatened or expiration, nonrenewal or expiration otherwise may occur.
- 13.5 Notice of Endorsement.** Prior to commencement of performance, Contractor shall provide to the Lead State a written endorsement to the Contractor's general liability insurance policy or other documentary evidence acceptable to the Lead State that (1) provides that written notice of cancellation will be delivered in accordance with the policy provisions, and (2) provides that the Contractor's liability insurance policy will be primary, with any liability insurance of any Participating State as secondary and noncontributory.
- 13.6 Participating Entities.** Contractor shall provide to Participating States and Participating Entities the same insurance obligations and documentation as those specified in Section XIII, except the endorsement is provided to the applicable Participating State or Participating Entity.
- 13.7 Furnishing of Certificates.** Contractor shall furnish to the Lead State copies of certificates of all required insurance in a form sufficient to show required coverage within thirty (30) calendar days of the execution of this Master Agreement and prior to performing any work. Copies of renewal certificates of all required insurance will be furnished within thirty (30) days after any renewal date to the applicable state Participating Entity. Failure to provide evidence of coverage may, at the sole option of the Lead State, or any Participating Entity, result in this Master Agreement's termination or the termination of any Participating Addendum.
- 13.8 Disclaimer.** Insurance coverage and limits will not limit Contractor's liability and obligations under this Master Agreement, any Participating Addendum, or any Purchase Order.

XIV. General Provisions

14.1 Records Administration and Audit

- 14.1.1** The Contractor shall maintain books, records, documents, and other evidence pertaining to this Master Agreement and Orders placed by Purchasing Entities under it to the extent and in such detail as will adequately reflect performance and administration of payments and fees. Contractor shall permit the Lead State, a Participating Entity, a Purchasing Entity, the federal government (including its grant awarding entities and the U.S. Comptroller General), and any other duly authorized agent of a governmental agency, to audit, inspect, examine, copy and/or transcribe Contractor's books, documents, papers and records directly pertinent to this Master Agreement or orders placed by a Purchasing Entity under it for the purpose of making audits, examinations, excerpts, and transcriptions. This right will survive for a period of six (6) years following termination of this Agreement or final payment for any order placed by a Purchasing Entity against this Master Agreement, whichever is later, or such longer period as is required by the Purchasing Entity's state statutes, to assure compliance with the terms hereof or to evaluate performance hereunder.
- 14.1.2** Without limiting any other remedy available to any governmental entity, the Contractor shall reimburse the applicable Lead State, Participating Entity, or Purchasing Entity for any overpayments inconsistent with the terms of the Master Agreement or Orders or underpayment of fees found as a result of the examination of the Contractor's records.
- 14.1.3** The rights and obligations herein exist in addition to any quality assurance obligation in the Master Agreement that requires the Contractor to self-audit contract obligations and that permits the Lead State to review compliance with those obligations.

14.2 Confidentiality, Non-Disclosure, and Injunctive Relief

- 14.2.1 Confidentiality.** Contractor acknowledges that it and its employees or agents may, in the course of providing a Product under this Master Agreement, be exposed to or acquire information that is confidential to Purchasing Entity or Purchasing Entity's clients.
- 14.2.1.1** Any and all information of any form that is marked as confidential or would by its nature be deemed confidential obtained by Contractor or its employees or agents in the performance of this Master Agreement, including but not necessarily limited to (1) any Purchasing Entity's records, (2) personnel records, and (3) information concerning individuals, is confidential information of Purchasing Entity ("Confidential Information").
 - 14.2.1.2** Any reports or other documents or items (including software) that result from the use of the Confidential Information by Contractor shall be treated in the same manner as the Confidential Information.
 - 14.2.1.3** Confidential Information does not include information that (1) is or becomes (other than by disclosure by Contractor) publicly known; (2) is furnished by Purchasing Entity to others without restrictions similar to those imposed by this Master Agreement; (3) is rightfully in Contractor's possession without the obligation of nondisclosure prior to the time of its disclosure under this Master Agreement; (4) is obtained from a source other than Purchasing Entity without the obligation of confidentiality, (5) is disclosed with the written consent of Purchasing Entity; or (6) is independently developed by employees, agents or subcontractors of Contractor who can be shown to have had no access to the Confidential Information.
- 14.2.2 Non-Disclosure.** Contractor shall hold Confidential Information in confidence, using at least the industry standard of confidentiality, and shall not copy, reproduce, sell, assign, license, market, transfer or otherwise dispose of, give, or disclose Confidential Information to third parties or use Confidential Information for any purposes whatsoever other than what is necessary to the performance of Orders placed under this Master Agreement.
- 14.2.2.1** Contractor shall advise each of its employees and agents of their obligations to keep Confidential Information confidential. Contractor shall use commercially reasonable efforts to assist Purchasing Entity in identifying and preventing any unauthorized use or disclosure of any Confidential Information.
 - 14.2.2.2** Without limiting the generality of the foregoing, Contractor shall advise Purchasing Entity, applicable Participating Entity, and the Lead State immediately if Contractor learns or has reason to believe that any person who has had access to Confidential Information has violated or intends to violate the terms of this Master Agreement, and Contractor shall at its expense cooperate with Purchasing Entity in seeking injunctive or other equitable relief in the name of Purchasing Entity or Contractor against any such person.
 - 14.2.2.3** Except as directed by Purchasing Entity, Contractor will not at any time during or after the term of this Master Agreement disclose, directly or indirectly, any Confidential Information to any person, except in accordance with this Master Agreement, and that upon termination of this Master Agreement or at Purchasing Entity's request, Contractor shall turn

over to Purchasing Entity all documents, papers, and other matter in Contractor's possession that embody Confidential Information.

14.2.2.4 Notwithstanding the foregoing, Contractor may keep one copy of such Confidential Information necessary for quality assurance, audits, and evidence of the performance of this Master Agreement.

14.2.3 Injunctive Relief. Contractor acknowledges that Contractor's breach of Section 14.2 would cause irreparable injury to the Purchasing Entity that cannot be inadequately compensated in monetary damages. Accordingly, Purchasing Entity may seek and obtain injunctive relief against the breach or threatened breach of the foregoing undertakings, in addition to any other legal remedies that may be available. Contractor acknowledges and agrees that the covenants contained herein are necessary for the protection of the legitimate business interests of Purchasing Entity and are reasonable in scope and content.

14.2.4 Purchasing Entity Law. These provisions will be applicable only to extent they are not in conflict with the applicable public disclosure laws of any Purchasing Entity.

14.2.5 NASPO ValuePoint. The rights granted to Purchasing Entities and Contractor's obligations under this section will also extend to NASPO ValuePoint's Confidential Information, including but not limited to Participating Addenda, Orders or transaction data relating to Orders under this Master Agreement that identify the entity/customer, Order dates, line-item descriptions and volumes, and prices/rates. This provision does not apply to disclosure to the Lead State, a Participating State, or any governmental entity exercising an audit, inspection, or examination pursuant to this Master Agreement. To the extent permitted by law, Contractor shall notify the Lead State of the identify of any entity seeking access to the Confidential Information described in this subsection.

14.2.6 Public Information. This Master Agreement and all related documents are subject to disclosure pursuant to the Lead State's public information laws.

14.3 Assignment/Subcontracts

14.3.1 Contractor shall not assign, sell, transfer, subcontract or sublet rights, or delegate responsibilities under this Master Agreement, in whole or in part, without the prior written approval of the Lead State.

14.3.2 The Lead State reserves the right to assign any rights or duties, including written assignment of contract administration duties, to NASPO ValuePoint and other third parties.

14.4 Changes in Contractor Representation. The Contractor must, within ten (10) calendar days, notify the Lead State in writing of any changes in the Contractor's key administrative personnel managing the Master Agreement. The Lead State reserves the right to approve or reject changes in key personnel, as identified in the Contractor's proposal. The Contractor shall propose replacement key personnel having substantially equal or better education, training, and experience as was possessed by the key person proposed and evaluated in the Contractor's proposal.

14.5 Independent Contractor. Contractor is an independent contractor. Contractor has no authorization, express or implied, to bind the Lead State, Participating States, other Participating Entities, or Purchasing Entities to any agreements, settlements, liability or understanding whatsoever, and shall not to hold itself out as agent except as expressly set forth herein or as expressly set forth in an applicable Participating Addendum or Order.

14.6 Cancellation. Unless otherwise set forth herein, this Master Agreement may be canceled by either party upon sixty (60) days' written notice prior to the effective date of the cancellation.

Further, any Participating Entity may cancel its participation upon thirty (30) days' written notice, unless otherwise limited or stated in the Participating Addendum. Cancellation may be in whole or in part. Any cancellation under this provision will not affect the rights and obligations attending Orders outstanding at the time of cancellation, including any right of a Purchasing Entity to indemnification by the Contractor, rights of payment for Products delivered and accepted, rights attending any warranty or default in performance in association with any Order, and requirements for records administration and audit. Cancellation of the Master Agreement due to Contractor default may be immediate.

14.7 Force Majeure. Neither party to this Master Agreement shall be held responsible for delay or default caused by fire, riot, unusually severe weather, other acts of God, or acts of war which are beyond that party's reasonable control. The Lead State may terminate this Master Agreement upon determining such delay or default will reasonably prevent successful performance of the Master Agreement.

14.8 Defaults and Remedies

14.8.1 The occurrence of any of the following events will be an event of default under this Master Agreement:

14.8.1.1 Nonperformance of contractual requirements;

14.8.1.2 A material breach of any term or condition of this Master Agreement;

14.8.1.3 Any certification, representation or warranty by Contractor in response to the solicitation or in this Master Agreement that proves to be untrue or materially misleading;

14.8.1.4 Institution of proceedings under any bankruptcy, insolvency, reorganization or similar law, by or against Contractor, or the appointment of a receiver or similar officer for Contractor or any of its property, which is not vacated or fully stayed within thirty (30) calendar days after the institution or occurrence thereof; or

14.8.1.5 Any default specified in another section of this Master Agreement.

14.8.2 Upon the occurrence of an event of default, the Lead State shall issue a written notice of default, identifying the nature of the default, and providing a period of fifteen (15) calendar days in which Contractor shall have an opportunity to cure the default. The Lead State shall not be required to provide advance written notice or a cure period and may immediately terminate this Master Agreement in whole or in part if the Lead State, in its sole discretion, determines that it is reasonably necessary to preserve public safety or prevent immediate public crisis. Time allowed for cure will not diminish or eliminate Contractor's liability for damages, including liquidated damages to the extent provided for under this Master Agreement.

14.8.3 If Contractor is afforded an opportunity to cure and fails to cure the default within the period specified in the written notice of default, Contractor shall be in breach of its obligations under this Master Agreement and the Lead State shall have the right to exercise any or all of the following remedies:

14.8.3.1 Any remedy provided by law;

14.8.3.2 Termination of this Master Agreement and any related Contracts or portions thereof;

14.8.3.3 Assessment of liquidated damages as provided in this Master Agreement;

14.8.3.4 Suspension of Contractor from being able to respond to future bid solicitations;

14.8.3.5 Suspension of Contractor's performance; and

14.8.3.6 Withholding of payment until the default is remedied.

14.8.4 Unless otherwise specified in the Participating Addendum, in the event of a default under a Participating Addendum, a Participating Entity shall provide a written notice of default as described in this section and shall have all of the rights and remedies under this paragraph regarding its participation in the Master Agreement, in addition to those set forth in its Participating Addendum. Unless otherwise specified in an Order, a Purchasing Entity shall provide written notice of default as described in this section and have all of the rights and remedies under this paragraph and any applicable Participating Addendum with respect to an Order placed by the Purchasing Entity. Nothing in these Master Agreement Terms and Conditions will be construed to limit the rights and remedies available to a Purchasing Entity under the applicable commercial code.

14.9 Waiver of Breach. Failure of the Lead State, Participating Entity, or Purchasing Entity to declare a default or enforce any rights and remedies will not operate as a waiver under this Master Agreement, any Participating Addendum, or any Purchase Order. Any waiver by the Lead State, Participating Entity, or Purchasing Entity must be in writing. Waiver by the Lead State or Participating Entity of any default, right or remedy under this Master Agreement or Participating Addendum, or by Purchasing Entity with respect to any Purchase Order, or breach of any terms or requirements of this Master Agreement, a Participating Addendum, or Purchase Order will not be construed or operate as a waiver of any subsequent default or breach of such term or requirement, or of any other term or requirement under this Master Agreement, any Participating Addendum, or any Purchase Order.

14.10 Debarment. The Contractor certifies that neither it nor its principals are presently debarred, suspended, proposed for debarment, declared ineligible, or voluntarily excluded from participation in public procurement or contracting by any governmental department or agency. This certification represents a recurring certification made at the time any Order is placed under this Master Agreement. If the Contractor cannot certify this statement, attach a written explanation for review by the Lead State.

14.11 No Waiver of Sovereign Immunity

14.11.1 In no event will this Master Agreement, any Participating Addendum or any contract or any Purchase Order issued thereunder, or any act of the Lead State, a Participating Entity, or a Purchasing Entity be a waiver of any form of defense or immunity, whether sovereign immunity, governmental immunity, immunity based on the Eleventh Amendment to the Constitution of the United States or otherwise, from any claim or from the jurisdiction of any court.

14.11.2 This section applies to a claim brought against the Participating Entities who are states only to the extent Congress has appropriately abrogated the state's sovereign immunity and is not consent by the state to be sued in federal court. This section is also not a waiver by the state of any form of immunity, including but not limited to sovereign immunity and immunity based on the Eleventh Amendment to the Constitution of the United States.

14.12 Governing Law and Venue

14.12.1 The procurement, evaluation, and award of the Master Agreement will be governed by and construed in accordance with the laws of the Lead State sponsoring and administering the procurement. The construction and effect of the Master Agreement after award will be governed by the law of the state serving as Lead State. The construction and effect of any Participating Addendum or Order against the Master

Agreement will be governed by and construed in accordance with the laws of the Participating Entity's or Purchasing Entity's state.

14.12.2 Unless otherwise specified in the RFP, the venue for any protest, claim, dispute or action relating to the procurement, evaluation, and award is in the state serving as Lead State. Venue for any claim, dispute or action concerning the terms of the Master Agreement will be in the state serving as Lead State. Venue for any claim, dispute, or action concerning any Order placed against the Master Agreement or the effect of a Participating Addendum will be in the Purchasing Entity's state.

14.12.3 If a claim is brought in a federal forum, then it must be brought and adjudicated solely and exclusively within the United States District Court for (in decreasing order of priority): the Lead State for claims relating to the procurement, evaluation, award, or contract performance or administration if the Lead State is a party; a Participating State if a named party; the state where the Participating Entity or Purchasing Entity is located if either is a named party.

14.13 Assignment of Antitrust Rights. Contractor irrevocably assigns to a Participating Entity who is a state any claim for relief or cause of action which the Contractor now has or which may accrue to the Contractor in the future by reason of any violation of state or federal antitrust laws (15 U.S.C. § 1-15 or a Participating Entity's state antitrust provisions), as now in effect and as may be amended from time to time, in connection with any goods or services provided in that state for the purpose of carrying out the Contractor's obligations under this Master Agreement or Participating Addendum, including, at the Participating Entity's option, the right to control any such litigation on such claim for relief or cause of action.

Section 7: Lead State (State of Arizona) Terms and Conditions

7.1 State of Arizona Special terms and Conditions

A. Purpose

Pursuant to provisions of the Arizona Procurement Code, A.R.S. §§ 41-2501 *et seq.*, the State of Arizona intends to establish a Contract (Participating Addendum, PA) for the materials or services as listed herein on service to the State.

B. Licenses

Contractor shall maintain in current status all Federal, State and Local licenses and permits required for the operation of a business conducted by the contractor.

C. Volume of Work

The State does not guarantee a specific amount of work either for the life of the Contract or on an annual basis.

D. Key Personnel

It is essential that the contractor provide an adequate staff of experienced personnel, capable of and devoted to the successful accomplishment of work to be performed under this contract. The contractor must assign specific individuals to the key positions.

1. The Contractor agrees that, once assigned to work under this Contract, key personnel shall not be removed or replaced without written notice to the State.
2. Key personnel who are not available for work under this Contract for a continuous period exceeding thirty (30) calendar days, or are expected to devote substantially less effort to the work than initially anticipated, the contractor shall immediately notify the State and shall subject to the concurrence of the State, replace such personnel of substantially equal ability and qualifications.

E. Price or Rate Adjustment

Any price or rate adjustment shall be within the confines of the awarded contract, or as negotiated in service to this Contract. Any price or rate adjustment requested must not exceed the Producers Price Index (PPI) by Industry: Other Commercial and Service Industry Machinery Manufacturing: Mailing, Letter Handling, and Addressing Machines, Except Parts and Attachments, Series ID: PCU3333183333183A at time of requested adjustment. Any negotiated price adjustments for this Contract shall be documented via a bilateral Contract Amendment.

F. Information Disclosure

The Contractor shall establish and maintain procedures and controls that are acceptable to the State for the purpose of assuring that no information contained in its records or obtained from the state or from others in carrying out its functions under the contract shall be used or disclosed by it, its agents, officers, or employees, except as required to efficiently perform duties under the Contract. Persons requesting such information should be referred to the State. The Contractor also agrees that any information pertaining to individual persons shall not be divulged other than to employees or officers of the Contractor as needed for the performance of duties under the Contract, unless otherwise agreed to in writing by the State.

G. Employees of the Contractor

All employees of the Contractor employed in the performance of work under the Contract shall be considered employees of the Contractor at all times, and not employees of the State. The Contractor shall comply with the Social Security Act, Workman's Compensation laws and Unemployment laws of the State of Arizona and all State, local and Federal legislation relevant to the Contractor's business.

H. Warranty

All services supplied under this Contract shall be fully guaranteed by the Contractor for a minimum period of ninety (90) days from the date of acceptance by the State. Any defects of design, workmanship, or delivered materials that would result in non-compliance shall be fully corrected by the Contractor without cost to the State.

I. Non-Exclusive Contract

Any Contract resulting from this solicitation shall be awarded with the understanding and agreement that it is for the sole convenience of the State of Arizona. The State reserves the right to obtain like goods or services from another source when necessary, or when determined to be in the best interest of the State.

1. Method of Assessment:

At the completion of each quarter, the contractor reviews all sales under their contract in preparation for submission of their Usage Report. The contractor identifies all sales receipts transacted by members of the State Purchasing Cooperative and assesses one percent (1.0%) of this amount in their Usage Report. An updated list of State Purchasing Cooperative members may be found at: <https://spo.az.gov/state-purchasing-cooperative>. At its option, the State may expand or narrow the applicability of this fee. The State shall provide thirty (30) written notice prior to exercising or changing this option. The contractor shall summarize all sales, along with all assessed Administrative Fee amounts within their Usage Report, including total amounts for the following:

- Total sales receipts from State agencies, boards and commissions;
- Total sales receipts from members of the State Purchasing Cooperative; and
- Total Administrative Fee amount based on one percent (1.0%) of the sales receipts from members of the State Purchasing Cooperative.

2. Submission of Reports and Fees:

Within thirty (30) days following the end of the quarter, the contractor submits their Usage Report and if applicable, a check in the amount of one percent (1%) of their sales receipts from members of the State Purchasing Cooperative, to the Department of Administration, State Procurement Office. Contractors are required to use the State's current report templates unless you have authorization from your contract officer to use a different format. You need to complete Form 799, which is a cover letter that gives the totals of your transactions; and Form 801, which is an Excel spreadsheet that details your transactions. Sales to state agencies and the cooperative members are to be totaled separately. The most current forms can be downloaded at <https://spo.az.gov/statewide-contracts-administrative-fee>.

4.1 The submission schedule for Administrative Fees and Usage reports shall be as follows:

FY Q1, July through September Due October 31

FY Q2, October through December Due January 31

FY Q3, January through March Due by April 30

FY Q4, April through June Due by July 31

2.2 Usage Reports and any questions are to be submitted by email to the state's designated usage report email address: usage@azdoa.gov

3. Administrative Fee

The Administrative Fee shall be a part of the Contractor's unit prices and is not to be charged directly to the customer in the form of a separate line item. Statewide contracts shall not have separate prices for State Agency customers and State Purchasing Cooperative customers.

4. Contractor's failure to remit administrative fees

Contractor's failure to remit administrative fees in a timely manner consistent with the contract's requirements may result in the State exercising any recourse available under the contract or as provided for by law.

J. Compensation

Should the Contractor fail to provide all required services or deliver work products, as agreed upon by State and the Contractor, the State shall be entitled to invoke applicable remedies, including but not limited to, withholding payment to the Contractor and declaring the Contractor in material breach of the Contract. If the Contractor is in any manner in default of any obligation or the Contractor's work or performance is determined by the State to be defective, sub-standard, or if audit exceptions are identified, the State may, in addition to other available remedies, either adjust the amount of payment or withhold payment until satisfactory resolution of the default, defect, exception or sub-standard performance. The Contractor shall reimburse the State on demand, or the State may deduct from future payments, any amounts paid for work products or performance which are determined to be an audit exception, defective or sub-standard performance. The Contractor shall correct its mistakes or errors without additional cost to the State. The State shall be the sole determiner as to defective or sub-standard performance.

The Contractor shall fulfill their contractual requirements including the Deliverables identified in the Statement of Work and fulfill the roles and responsibilities described in the Statement of Work for a firm fixed price, inclusive of travel and travel-related expenses. The fixed amount shall be inclusive of any fees for the use of any third party products or services required for use in the performance of this Contract.

K. Offshore Performance of Work Prohibited

Due to security and identity protection concerns, direct services under this contract shall be performed within the borders of the United States. Any services that are described in the specifications or scope of work that directly serve the State of Arizona or its clients and may involve access to secure or sensitive data or personal client data or development or modification of software for the State shall be performed within the borders of the United States. Unless specifically stated otherwise in the specifications, this definition does not apply to indirect or "overhead" services, redundant back-up services or services that are incidental to the performance of the contract. This provision applies to work performed by subcontractors at all tiers.

L. Indemnification and Insurance

1.1 To the fullest extent permitted by law, Contractor shall defend, indemnify, and hold harmless the State of Arizona, and its departments, agencies, boards, commissions, universities, and any jurisdiction or agency issuing permits for any work included in the project, and their respective directors, officers, officials, agents and employees (hereinafter referred to as "Indemnitee") from and against any and all claims, actions, liabilities, costs, losses, or expenses, (including reasonable attorney's fees), (hereinafter collectively referred to as "Claims") arising out of actual or alleged bodily injury or personal injury of any person (including death) or

loss or damage to tangible or intangible property caused, or alleged to be caused, in whole or in part, by the negligent or willful acts or omissions of Contractor or any of Contractor's directors, officers, agents, employees, volunteers or subcontractors. This indemnity includes any claim or amount arising or recovered under the Workers' Compensation Law or arising out of the failure of Contractor to conform to any federal, state or local law, statute, ordinance, rule, regulation or court decree. It is the specific intention of the parties that the Indemnitee shall, in all instances, except for Claims arising solely from the negligent or willful acts or omissions of the Indemnitee, be indemnified by Contractor from and against any and all Claims. It is agreed that Contractor will be responsible for primary loss investigation, defense and judgment costs where this indemnification is applicable. This indemnification will survive the termination of the above listed contract with the Contractor.

This indemnity shall not apply if the contractor or sub-contractor(s) is/are an agency, board, commission or university of the State of Arizona.

1.2 Insurance Requirements

1.2.1 Contractor and subcontractors shall procure and maintain, until all of their obligations have been discharged, including any warranty periods under this Contract, insurance against claims for injury to persons or damage to property arising from, or in connection with, the performance of the work hereunder by the Contractor, its agents, representatives, employees or subcontractors.

1.2.2 The Insurance Requirements herein are minimum requirements for this Contract and in no way limit the indemnity covenants contained in this Contract. The State of Arizona in no way warrants that the minimum limits contained herein are sufficient to protect the Contractor from liabilities that arise out of the performance of the work under this Contract by the Contractor, its agents, representatives, employees or subcontractors, and the Contractor is free to purchase additional insurance.

1.3 Minimum Scope and Limits of Insurance

Contractor shall provide coverage with limits of liability not less than those stated below.

1.3.1 Commercial General Liability (CGL) – Occurrence Form Policy shall include bodily injury, property damage, and broad form contractual liability coverage.

General Aggregate	\$2,000,000
Products – Completed Operations Aggregate	\$1,000,000
Personal and Advertising Injury	\$1,000,000
Damage to Rented Premises	\$50,000
Each Occurrence	\$1,000,000

- a. The policy shall be endorsed, as required by this written agreement, to include the State of Arizona, and its departments, agencies, boards, commissions, universities, officers, officials, agents, and employees as additional insureds with respect to liability arising out of the activities performed by or on behalf of the Contractor
- b. Policy shall contain a waiver of subrogation endorsement, as required by this written agreement, in favor of the State of Arizona, and its departments, agencies, boards, commissions, universities, officers, officials, agents, and employees for losses arising from work performed by or on behalf of the Contractor.

1.3.2 Business Automobile Liability

Bodily Injury and Property Damage for any owned, hired, and/or non-owned automobiles used in the performance of this Contract.

- Combined Single Limit (CSL) \$1,000,000

Policy shall be endorsed, as required by this written agreement, to include the State of Arizona, and its departments, agencies, boards, commissions, universities, officers, officials, agents, and employees as additional insureds with respect to liability arising out of the activities performed by, or on behalf of, the Contractor involving automobiles owned, hired and/or non-owned by the Contractor.

- c. Policy shall contain a waiver of subrogation endorsement as required by this written agreement in favor of the State of Arizona, and its departments, agencies, boards, commissions, universities, officers, officials, agents, and employees for losses arising from work performed by or on behalf of the Contractor.

1.3.3 Workers' Compensation and Employers' Liability

- Workers' Compensation Statutory
- Employers' Liability
- Each Accident \$1,000,000
- Disease – Each Employee \$1,000,000
- Disease – Policy Limit \$1,000,000

- d Policy shall contain a waiver of subrogation endorsement, as required by this written agreement, in favor of the State of Arizona, and its departments, agencies, boards, commissions, universities, officers, officials, agents, and employees for losses arising from work performed by or on behalf of the Contractor.
- e This requirement shall not apply to each Contractor or subcontractor that is exempt under A.R.S. § 23-901, and when such Contractor or subcontractor executes the appropriate waiver form (Sole Proprietor or Independent Contractor).

1.3.4 Technology Errors & Omissions Insurance

- Each Claim \$2,000,000
- Annual Aggregate \$2,000,000

- f Such insurance shall cover any, and all errors, omissions, or negligent acts in the delivery of products, services, and/or licensed programs under this contract.
- g Coverage shall include or shall not exclude settlement and/or defense of claims involving intellectual property, including but not limited to patent or copyright infringement.
- h In the event that the Tech E&O insurance required by this Contract is written on a claims-made basis, Contractor warrants that any retroactive date under the policy shall precede the effective date of this Contract and, either continuous coverage will be maintained or an extended discovery period will be exercised for a period of two (2) years, beginning at the time work under this Contract is completed.

1.3.5 Media Liability Coverage

- Each Claim \$2,000,000
- Annual Aggregate \$2,000,000

- i Such insurance shall cover any and all errors and omissions or negligent acts in the production of content, including but not limited to plagiarism, defamation, libel, slander, false advertising, invasion of privacy, and infringement of copyright, title, slogan, trademark, service mark and trade dress.
- j In the event that the Media Liability insurance required by this Contract is written on a claims-made basis, Contractor warrants that any retroactive date under the policy shall precede the effective date of this Contract and, either continuous coverage will be maintained, or an extended discovery period will be

exercised for a period of two (2) years beginning at the time work under this Contract is completed.

1.4 Additional Insurance Requirements

The policies shall include, or be endorsed to include, as required by this written agreement, the following provisions:

1.4.1 The Contractor's policies, as applicable, shall stipulate that the insurance afforded the Contractor shall be primary and that any insurance carried by the Department, its agents, officials, employees or the State of Arizona shall be excess and not contributory insurance, as provided by A.R.S. § 41-621 (E).

1.4.2 Insurance provided by the Contractor shall not limit the Contractor's liability assumed under the indemnification provisions of this Contract

1.5 Notice of Cancellation

Applicable to all insurance policies required within the Insurance Requirements of this Contract, Contractor's insurance shall not be permitted to expire, be suspended, be canceled, or be materially changed for any reason without thirty (30) days prior written notice to the State of Arizona. Within two (2) business days of receipt, Contractor must provide notice to the State of Arizona if they receive notice of a policy that has been or will be suspended, canceled, materially changed for any reason, has expired, or will be expiring. Such notice shall be sent directly to the Department and shall be mailed, emailed, hand delivered or sent by facsimile transmission to (State Representative's Name, Address & Fax Number).

1.6 Acceptability of Insurers

Contractor's insurance shall be placed with companies licensed in the State of Arizona or hold approved non-admitted status on the Arizona Department of Insurance List of Qualified Unauthorized Insurers. Insurers shall have an "A.M. Best" rating of not less than A- VII. The State of Arizona in no way warrants that the above-required minimum insurer rating is sufficient to protect the Contractor from potential insurer insolvency.

1.7 Verification of Coverage

Contractor shall furnish the State of Arizona with certificates of insurance (valid ACORD form or equivalent approved by the State of Arizona) as required by this Contract. An authorized representative of the insurer shall sign the certificates.

1.7.1 All certificates and endorsements, as required by this written agreement, are to be received and approved by the State of Arizona before work commences. Each insurance policy required by this Contract must be in effect at, or prior to, commencement of work under this Contract. Failure to maintain the insurance policies as required by this Contract, or to provide evidence of renewal, is a material breach of contract.

1.7.2 All certificates required by this Contract shall be sent directly to the Department. The State of Arizona project/contract number and project description shall be noted on the certificate of insurance. The State of Arizona reserves the right to require complete copies of all insurance policies required by this Contract at any time.

1.8 Subcontractors

Contractor's certificate(s) shall include all subcontractors as insureds under its policies or Contractor shall be responsible for ensuring and/or verifying that all subcontractors have valid and collectable insurance as evidenced by the certificates of insurance and endorsements for each subcontractor. All coverages for subcontractors shall be subject to the minimum Insurance Requirements identified above. The Department reserves the right to require, at any time throughout the life of this contract, proof from the Contractor that its subcontractors have the required coverage.

1.9 Approval and Modifications

The Contracting Agency, in consultation with State Risk, reserves the right to review or make modifications to the insurance limits, required coverages, or endorsements throughout the life of this contract, as deemed necessary. Such action will not require a formal Contract amendment but may be made by administrative action.

1.10 Exceptions

In the event the Contractor or subcontractor(s) is/are a public entity, then the Insurance Requirements shall not apply. Such public entity shall provide a certificate of self-insurance. If the Contractor or subcontractor(s) is/are a State of Arizona agency, board, commission, or university, none of the above shall apply.

P. Data Privacy/Security Incident Management

Contractor and its agents shall cooperate and collaborate with appropriate State personnel to identify and respond to an information security or data privacy incident, including a security breach.

1. Threat of Security Breach

Contractor(s) agrees to notify the State Chief Information Officer (CIO), the State Chief Information Security Officer (CISO) and other key personnel as identified by the State of any perceived threats placing the supported infrastructure and/or applications in danger of breach of security. The speed of notice shall be at least commensurate with the level of threat, as perceived by the Contractor(s). The State agrees to provide contact information for the State CIO, CISO and key personnel to the Contractor(s).

2. Discovery of Security Breach

Contractor agrees to immediately notify the State CIO, the CISO and key personnel as identified by the State of a discovered breach of security. The State agrees to provide contact information for the State CIO, the CISO and key personnel.

Q. Access Constraints and Requirements

Contractor access to State facilities and resources shall be properly authorized by State personnel, based on business need and will be restricted to least possible privilege. Upon approval of access privileges, the Contractor shall maintain strict adherence to all policies, standards, and procedures. Policies / Standards, ADOA/ASET Policies / Procedures, and Arizona Revised Statutes (A.R.S.) §28-447, §28-449, §38-421, §13-2408, §13-2316, §41-770.

Failure of the Contractor, its agents or subcontractors to comply with policies, standards, and procedures including any person who commits an unlawful breach or harmful access (physical or virtual) will be subject to prosecution under all applicable state and / or federal laws.

Any and all recovery or reconstruction costs or other liabilities associated with an unlawful breach or harmful access shall be paid by the Contractor.

R. Compliance Requirements for A.R.S. § 41-4401, Government Procurement: E-Verify Requirement

1. The Contractor warrants compliance with all Federal immigration laws and regulations relating to employees and warrants its compliance with Section A.R.S. § 23-214, Subsection A. (That subsection reads: "After December 31, 2007, every employer, after hiring an employee, shall verify the employment eligibility of the employee through the E-Verify program.)

2. A breach of a warranty regarding compliance with immigration laws and regulations shall be deemed a material breach of the Contract and the

Contractor may be subject to penalties up to and including termination of the Contract.

3. Failure to comply with a State audit process to randomly verify the employment records of Contractors and subcontractors shall be deemed a material breach of the Contract and the Contractor may be subject to penalties up to and including termination of the Contract.
4. The State Agency retains the legal right to inspect the papers of any employee who works on the Contract to ensure that the Contractor or subcontractor is complying with the warranty under paragraph One (1).

7.2 State of Arizona Uniform Terms and Conditions

1. Definition of Terms

As used in this Solicitation and any resulting Contract, the terms listed below are defined as follows:

- 1.1. *"Attachment"* means any item the Solicitation requires the Offeror to submit as part of the Offer.
- 1.2. *"Contract"* means the combination of the Solicitation, including the Uniform and Special Instructions to Offerors, the Uniform and Special Terms and Conditions, and the Specifications and Statement or Scope of Work; the Offer and any Best and Final Offers; and any Solicitation Amendments or Contract Amendments.
- 1.3. *"Contract Amendment"* means a written document signed by the Procurement Officer that is issued for the purpose of making changes in the Contract.
- 1.4. *"Contractor"* means any person who has a Contract with the State.
- 1.5. *"Days"* means calendar days unless otherwise specified.
- 1.6. *"Exhibit"* means any item labeled as an Exhibit in the Solicitation or placed in the Exhibits section of the Solicitation.
- 1.7. *"Gratuity"* means a payment, loan, subscription, advance, deposit of money, services, or anything of more than nominal value, present or promised, unless consideration of substantially equal or greater value is received.
- 1.8. *"Materials"* means all property, including equipment, supplies, printing, insurance and leases of property but does not include land, a permanent interest in land or real property or leasing space.

- 1.9. *"Procurement Officer"* means the person, or his or her designee, duly authorized by the State to enter into and administer Contracts and make written determinations with respect to the Contract.
- 1.10. *"Services"* means the furnishing of labor, time or effort by a contractor or subcontractor which does not involve the delivery of a specific end product other than required reports and performance, but does not include employment agreements or collective bargaining agreements.
- 1.11. *"Subcontract"* means any Contract, express or implied, between the Contractor and another party or between a subcontractor and another party delegating or assigning, in whole or in part, the making or furnishing of any material or any service required for the performance of the Contract.
- 1.12. *"State"* means the State of Arizona and Department or Agency of the State that executes the Contract.
- 1.13. *"State Fiscal Year"* means the period beginning with July 1 and ending June 30.

2. Contract Interpretation

- 2.1. **Arizona Law.** The Arizona law applies to this Contract including, where applicable, the Uniform Commercial Code as adopted by the State of Arizona and the Arizona Procurement Code, Arizona Revised Statutes (A.R.S.) Title 41, Chapter 23, and its implementing rules, Arizona Administrative Code (A.A.C.) Title 2, Chapter 7.
- 2.2. **Implied Contract Terms.** Each provision of law and any terms required by law to be in this Contract are a part of this Contract as if fully stated in it.
- 2.3. **Contract Order of Precedence.** In the event of a conflict in the provisions of the Contract, as accepted by the State and as they may be amended, the following shall prevail in the order set forth below:
 - 2.3.1. Special Terms and Conditions;
 - 2.3.2. Uniform Terms and Conditions;
 - 2.3.3. Statement or Scope of Work;
 - 2.3.4. Specifications;
 - 2.3.5. Attachments;
 - 2.3.6. Exhibits;
 - 2.3.7. Documents referenced or included in the Solicitation.
- 2.4. **Relationship of Parties.** The Contractor under this Contract is an independent Contractor. Neither party to this Contract shall be deemed to be the employee or agent of the other party to the Contract.

- 2.5. Severability. The provisions of this Contract are severable. Any term or condition deemed illegal or invalid shall not affect any other term or condition of the Contract.
- 2.6. No Parole Evidence. This Contract is intended by the parties as a final and complete expression of their agreement. No course of prior dealings between the parties and no usage of the trade shall supplement or explain any terms used in this document and no other understanding either oral or in writing shall be binding.
- 2.7. No Waiver. Either party's failure to insist on strict performance of any term or condition of the Contract shall not be deemed a waiver of that term or condition even if the party accepting or acquiescing in the nonconforming performance knows of the nature of the performance and fails to object to it.

3. Contract Administration and Operation

- 3.1. Records. Under A.R.S. § 35-214 and § 35-215, the Contractor shall retain and shall contractually require each subcontractor to retain all data and other "records" relating to the acquisition and performance of the Contract for a period of five years after the completion of the Contract. All records shall be subject to inspection and audit by the State at reasonable times. Upon request, the Contractor shall produce a legible copy of any or all such records.
- 3.2. Non-Discrimination. The Contractor shall comply with State Executive Order No. 2009-09 and all other applicable Federal and State laws, rules and regulations, including the Americans with Disabilities Act.
- 3.3. Audit. Pursuant to ARS § 35-214, at any time during the term of this Contract and five (5) years thereafter, the Contractor's or any subcontractor's books and records shall be subject to audit by the State and, where applicable, the Federal Government, to the extent that the books and records relate to the performance of the Contract or Subcontract.
- 3.4. Facilities Inspection and Materials Testing. The Contractor agrees to permit access to its facilities, subcontractor facilities and the Contractor's processes or services, at reasonable times for inspection of the facilities or materials covered under this Contract. The State shall also have the right to test, at its own cost, the materials to be supplied under this Contract. Neither inspection of the Contractor's facilities nor materials testing shall constitute final acceptance of the materials or services. If the State determines non-compliance of the materials, the Contractor shall be responsible for the payment of all costs incurred by the State for testing and inspection.

- 3.5. Notices. Notices to the Contractor required by this Contract shall be made by the State to the person indicated on the Offer and Acceptance form submitted by the Contractor unless otherwise stated in the Contract. Notices to the State required by the Contract shall be made by the Contractor to the Solicitation Contact Person indicated on the Solicitation cover sheet, unless otherwise stated in the Contract. An authorized Procurement Officer and an authorized

Contractor representative may change their respective person to whom notice shall be given by written notice to the other and an amendment to the Contract shall not be necessary.

- 3.6. Advertising, Publishing and Promotion of Contract. The Contractor shall not use, advertise or promote information for commercial benefit concerning this Contract without the prior written approval of the Procurement Officer.
- 3.7. Property of the State. Any materials, including reports, computer programs and other deliverables, created under this Contract are the sole property of the State. The Contractor is not entitled to a patent or copyright on those materials and may not transfer the patent or copyright to anyone else. The Contractor shall not use or release these materials without the prior written consent of the State.
- 3.8. Ownership of Intellectual Property. Any and all intellectual property, including but not limited to copyright, invention, trademark, trade name, service mark, and/or trade secrets created or conceived pursuant to or as a result of this contract and any related subcontract ("Intellectual Property"), shall be work made for hire and the State shall be considered the creator of such Intellectual Property. The agency, department, division, board or commission of the State of Arizona requesting the issuance of this contract shall own (for and on behalf of the State) the entire right, title and interest to the Intellectual Property throughout the world. Contractor shall notify the State, within thirty (30) days, of the creation of any Intellectual Property by it or its subcontractor(s). Contractor, on behalf of itself and any subcontractor(s), agrees to execute any and all document(s) necessary to assure ownership of the Intellectual Property vests in the State and shall take no affirmative actions that might have the effect of vesting all or part of the Intellectual Property in any entity other than the State. The Intellectual Property shall not be disclosed by contractor or its subcontractor(s) to any entity not the State without the express written authorization of the agency, department, division, board or commission of the State of Arizona requesting the issuance of this contract.
- 3.9. Federal Immigration and Nationality Act. The contractor shall comply with all federal, state and local immigration laws and regulations relating

to the immigration status of their employees during the term of the contract. Further, the contractor shall flow down this requirement to all subcontractors utilized during the term of the contract. The State shall retain the right to perform random audits of contractor and subcontractor records or to inspect papers of any employee thereof to ensure compliance. Should the State determine that the contractor and/or any subcontractors be found noncompliant, the State may pursue all remedies allowed by law, including, but not limited to; suspension of work, termination of the contract for default and suspension and/or debarment of the contractor.

3.10 E-Verify Requirements. In accordance with A.R.S. § 41-4401, Contractor warrants compliance with all Federal immigration laws and regulations relating to employees and warrants its compliance with Section A.R.S. § 23-214, Subsection A.

3.11 Offshore Performance of Work Prohibited.

Any services that are described in the specifications or scope of work that directly serve the State of Arizona or its clients and involve access to secure or sensitive data or personal client data shall be performed within the defined territories of the United States. Unless specifically stated otherwise in the specifications, this paragraph does not apply to indirect or 'overhead' services, redundant back-up services or services that are incidental to the performance of the contract. This provision applies to work performed by subcontractors at all tiers.

4. Costs and Payments

4.1. Payments. Payments shall comply with the requirements of A.R.S. Titles 35 and 41, Net 30 days. Upon receipt and acceptance of goods or services, the Contractor shall submit a complete and accurate invoice for payment from the State within thirty (30) days.

4.2. Delivery. Unless stated otherwise in the Contract, all prices shall be F.O.B. Destination and shall include all freight delivery and unloading at the destination.

4.3. Applicable Taxes.

4.3.1. Payment of Taxes. The Contractor shall be responsible for paying all applicable taxes.

4.3.2. State and Local Transaction Privilege Taxes. The State of Arizona is subject to all applicable state and local transaction privilege taxes. Transaction privilege taxes apply to the sale and are the responsibility of the seller to remit. Failure to collect such taxes from the buyer does not relieve the seller from its obligation to remit taxes.

4.3.3. Tax Indemnification. Contractor and all subcontractors shall pay all Federal, state and local taxes applicable to its operation and any persons employed by the Contractor. Contractor shall, and require all subcontractors to hold the State harmless from any responsibility for taxes, damages and interest, if applicable, contributions required under Federal, and/or state and local laws and regulations and any other costs including transaction privilege taxes, unemployment compensation insurance, Social Security and Worker's Compensation.

4.3.4. IRS W9 Form. In order to receive payment, the Contractor shall have a current I.R.S. W9 Form on file with the State of Arizona, unless not required by law.

4.4. Availability of Funds for the Next State fiscal year. Funds may not presently be available for performance under this Contract beyond the current state fiscal year. No legal liability on the part of the State for any payment may arise under this Contract beyond the current state fiscal year until funds are made available for performance of this Contract.

4.5. Availability of Funds for the current State fiscal year. Should the State Legislature enter back into session and reduce the appropriations or for any reason and these goods or services are not funded, the State may take any of the following actions:

4.5.1. Accept a decrease in price offered by the contractor;

4.5.2. Cancel the Contract; or

4.5.3. Cancel the contract and re-solicit the requirements.

5. Contract Changes

5.1. Amendments. This Contract is issued under the authority of the Procurement Officer who signed this Contract. The Contract may be modified only through a Contract Amendment within the scope of the Contract. Changes to the Contract, including the addition of work or materials, the revision of payment terms, or the substitution of work or materials, directed by a person who is not specifically authorized by the procurement officer in writing or made unilaterally by the Contractor are violations of the Contract and of applicable law. Such changes, including unauthorized written Contract Amendments shall be void and without effect, and the Contractor shall not be entitled to any claim under this Contract based on those changes.

5.2. Subcontracts. The Contractor shall not enter into any Subcontract under this Contract for the performance of this contract without the advance written approval of the Procurement Officer. The Contractor shall clearly list any proposed subcontractors and the subcontractor's

proposed responsibilities. The Subcontract shall incorporate by reference the terms and conditions of this Contract.

- 5.3. Assignment and Delegation. The Contractor shall not assign any right nor delegate any duty under this Contract without the prior written approval of the Procurement Officer. The State shall not unreasonably withhold approval.

6. Risk and Liability

- 6.1. Risk of Loss: The Contractor shall bear all loss of conforming material covered under this Contract until received by authorized personnel at the location designated in the purchase order or Contract. Mere receipt does not constitute final acceptance. The risk of loss for nonconforming materials shall remain with the Contractor regardless of receipt.

6.2. Indemnification

6.2.1. Contractor/Vendor Indemnification (Not Public Agency) The parties to this contract agree that the State of Arizona, its departments, agencies, boards and commissions shall be indemnified and held harmless by the contractor for the vicarious liability of the State as a result of entering into this contract. However, the parties further agree that the State of Arizona, its departments, agencies, boards and commissions shall be responsible for its own negligence. Each party to this contract is responsible for its own negligence.

6.2.2. Public Agency Language Only Each party (as 'indemnitor') agrees to indemnify, defend, and hold harmless the other party (as 'indemnitee') from and against any and all claims, losses, liability, costs, or expenses (including reasonable attorney's fees) (hereinafter collectively referred to as 'claims') arising out of bodily injury of any person (including death) or property damage but only to the extent that such claims which result in vicarious/derivative liability to the indemnitee, are caused by the act, omission, negligence, misconduct, or other fault of the indemnitor, its officers, officials, agents, employees, or volunteers."

- 6.3. Indemnification - Patent and Copyright. The Contractor shall indemnify and hold harmless the State against any liability, including costs and expenses, for infringement of any patent, trademark or copyright arising out of Contract performance or use by the State of materials furnished or work performed under this Contract. The State shall reasonably notify the Contractor of any claim for which it may be liable under this paragraph. If the contractor is insured pursuant to A.R.S. § 41-621 and § 35-154, this section shall not apply.

6.4. Force Majeure.

6.4.1 Except for payment of sums due, neither party shall be liable to the other nor deemed in default under this Contract if and to the extent that such party's performance of this Contract is prevented by reason of force majeure. The term "*force majeure*" means an occurrence that is beyond the control of the party affected and occurs without its fault or negligence. Without limiting the foregoing, force majeure includes acts of God; acts of the public enemy; war; riots; strikes; mobilization; labor disputes; civil disorders; fire; flood; lockouts; injunctions-intervention-acts; or failures or refusals to act by government authority; and other similar occurrences beyond the control of the party declaring force majeure which such party is unable to prevent by exercising reasonable diligence.

6.4.2. Force Majeure shall not include the following occurrences:

6.4.2.1. Late delivery of equipment or materials caused by congestion at a manufacturer's plant or elsewhere, or an oversold condition of the market;

6.4.2.2. Late performance by a subcontractor unless the delay arises out of a force majeure occurrence in accordance with this force majeure term and condition; or

6.4.2.3. Inability of either the Contractor or any subcontractor to acquire or maintain any required insurance, bonds, licenses or permits.

6.4.3. If either party is delayed at any time in the progress of the work by force majeure, the delayed party shall notify the other party in writing of such delay, as soon as is practicable and no later than the following working day, of the commencement thereof and shall specify the causes of such delay in such notice. Such notice shall be delivered or mailed certified-return receipt and shall make a specific reference to this article, thereby invoking its provisions. The delayed party shall cause such delay to cease as soon as practicable and shall notify the other party in writing when it has done so. The time of completion shall be extended by Contract Amendment for a period of time equal to the time that results or effects of such delay prevent the delayed party from performing in accordance with this Contract.

6.4.4. Any delay or failure in performance by either party hereto shall not constitute default hereunder or give rise to any claim for damages or loss of anticipated profits if, and to the extent that such delay or failure is caused by force majeure.

- 6.5. Third Party Antitrust Violations. The Contractor assigns to the State any claim for overcharges resulting from antitrust violations to the extent that those violations concern materials or services supplied by third parties to the Contractor, toward fulfillment of this Contract.

7. Warranties

- 7.1. Liens. The Contractor warrants that the materials supplied under this Contract are free of liens and shall remain free of liens.
- 7.2. Quality. Unless otherwise modified elsewhere in these terms and conditions, the Contractor warrants that, for one year after acceptance by the State of the materials, they shall be:
 - 7.2.1. Of a quality to pass without objection in the trade under the Contract description;
 - 7.2.2. Fit for the intended purposes for which the materials are used;
 - 7.2.3. Within the variations permitted by the Contract and are of even kind, quantity, and quality within each unit and among all units;
 - 7.2.4. Adequately contained, packaged and marked as the Contract may require; and
 - 7.2.5. Conform to the written promises or affirmations of fact made by the Contractor.
- 7.3. Fitness. The Contractor warrants that any material supplied to the State shall fully conform to all requirements of the Contract and all representations of the Contractor, and shall be fit for all purposes and uses required by the Contract.
- 7.4. Inspection/Testing. The warranties set forth in subparagraphs 7.1 through 7.3 of this paragraph are not affected by inspection or testing of or payment for the materials by the State.
- 7.5. Compliance with Applicable Laws. The materials and services supplied under this Contract shall comply with all applicable Federal, state and local laws, and the Contractor shall maintain all applicable license and permit requirements.
- 7.6. Survival of Rights and Obligations after Contract Expiration or Termination.
 - 7.6.1. Contractor's Representations and Warranties. All representations and warranties made by the Contractor under this Contract shall survive the expiration or termination hereof. In addition, the parties hereto acknowledge that pursuant to A.R.S. § 12-510, except as provided in A.R.S. § 12-529, the State is not subject to or barred by any limitations of actions prescribed in A.R.S., Title 12, Chapter 5.

7.6.2. Purchase Orders. The Contractor shall, in accordance with all terms and conditions of the Contract, fully perform and shall be obligated to comply with all purchase orders received by the Contractor prior to the expiration or termination hereof, unless otherwise directed in writing by the Procurement Officer, including, without limitation, all purchase orders received prior to but not fully performed and satisfied at the expiration or termination of this Contract.

8. State's Contractual Remedies

- 8.1. Right to Assurance. If the State in good faith has reason to believe that the Contractor does not intend to, or is unable to perform or continue performing under this Contract, the Procurement Officer may demand in writing that the Contractor give a written assurance of intent to perform. Failure by the Contractor to provide written assurance within the number of Days specified in the demand may, at the State's option, be the basis for terminating the Contract under the Uniform Terms and Conditions or other rights and remedies available by law or provided by the contract.
- 8.2. Stop Work Order.
 - 8.2.1. The State may, at any time, by written order to the Contractor, require the Contractor to stop all or any part, of the work called for by this Contract for period(s) of days indicated by the State after the order is delivered to the Contractor. The order shall be specifically identified as a stop work order issued under this clause. Upon receipt of the order, the Contractor shall immediately comply with its terms and take all reasonable steps to minimize the incurrence of costs allocable to the work covered by the order during the period of work stoppage.
 - 8.2.2. If a stop work order issued under this clause is canceled or the period of the order or any extension expires, the Contractor shall resume work. The Procurement Officer shall make an equitable adjustment in the delivery schedule or Contract price, or both, and the Contract shall be amended in writing accordingly.
- 8.3. Non-exclusive Remedies. The rights and the remedies of the State under this Contract are not exclusive.
- 8.4. Nonconforming Tender. Materials or services supplied under this Contract shall fully comply with the Contract. The delivery of materials or services or a portion of the materials or services that do not fully comply constitutes a breach of contract. On delivery of nonconforming materials or services, the State may terminate the Contract for default under applicable termination clauses in the Contract, exercise any of its

rights and remedies under the Uniform Commercial Code, or pursue any other right or remedy available to it.

- 8.5. Right of Offset. The State shall be entitled to offset against any sums due the Contractor, any expenses or costs incurred by the State, or damages assessed by the State concerning the Contractor's non-conforming performance or failure to perform the Contract, including expenses, costs and damages described in the Uniform Terms and Conditions.

9. Contract Termination

- 9.1. Cancellation for Conflict of Interest. Pursuant to A.R.S. § 38-511, the State may cancel this Contract within three (3) years after Contract execution without penalty or further obligation if any person significantly involved in initiating, negotiating, securing, drafting or creating the Contract on behalf of the State is or becomes at any time while the Contract or an extension of the Contract is in effect an employee of or a consultant to any other party to this Contract with respect to the subject matter of the Contract. The cancellation shall be effective when the Contractor receives written notice of the cancellation unless the notice specifies a later time. If the Contractor is a political subdivision of the State, it may also cancel this Contract as provided in A.R.S. § 38-511.
- 9.2. Gratuities. The State may, by written notice, terminate this Contract, in whole or in part, if the State determines that employment or a Gratuity was offered or made by the Contractor or a representative of the Contractor to any officer or employee of the State for the purpose of influencing the outcome of the procurement or securing the Contract, an amendment to the Contract, or favorable treatment concerning the Contract, including the making of any determination or decision about contract performance. The State, in addition to any other rights or remedies, shall be entitled to recover exemplary damages in the amount of three times the value of the Gratuity offered by the Contractor.
- 9.3. Suspension or Debarment. The State may, by written notice to the Contractor, immediately terminate this Contract if the State determines that the Contractor has been debarred, suspended or otherwise lawfully prohibited from participating in any public procurement activity, including but not limited to, being disapproved as a subcontractor of any public procurement unit or other governmental body. Submittal of an offer or execution of a contract shall attest that the contractor is not currently suspended or debarred. If the contractor becomes suspended or debarred, the contractor shall immediately notify the State.

- 9.4. Termination for Convenience. The State reserves the right to terminate the Contract, in whole or in part at any time when in the best interest of the State, without penalty or recourse. Upon receipt of the written notice, the Contractor shall stop all work, as directed in the notice, notify all subcontractors of the effective date of the termination and minimize all further costs to the State.

In the event of termination under this paragraph, all documents, data and reports prepared by the Contractor under the Contract shall become the property of and be delivered to the State upon demand. The Contractor shall be entitled to receive just and equitable compensation for work in progress, work completed and materials accepted before the effective date of the termination. The cost principles and procedures provided in A.A.C. R2-7-701 shall apply.

- 9.5. Termination for Default.

9.5.1. In addition to the rights reserved in the contract, the State may terminate the Contract in whole or in part due to the failure of the Contractor to comply with any term or condition of the Contract, to acquire and maintain all required insurance policies, bonds, licenses and permits, or to make satisfactory progress in performing the Contract. The Procurement Officer shall provide written notice of the termination and the reasons for it to the Contractor.

9.5.2. Upon termination under this paragraph, all goods, materials, documents, data and reports prepared by the Contractor under the Contract shall become the property of and be delivered to the State on demand.

9.5.3. The State may, upon termination of this Contract, procure, on terms and in the manner that it deems appropriate, materials or services to replace those under this Contract. The Contractor shall be liable to the State for any excess costs incurred by the State in procuring materials or services in substitution for those due from the Contractor.

- 9.6. Continuation of Performance through Termination. The Contractor shall continue to perform, in accordance with the requirements of the Contract, up to the date of termination, as directed in the termination notice.

10. Contract Claims

All contract claims or controversies under this Contract shall be resolved according to A.R.S. Title 41, Chapter 23, Article 9, and rules adopted thereunder.

11. Arbitration

The parties to this Contract agree to resolve all disputes arising out of or relating to this contract through arbitration, after exhausting applicable administrative review, to the extent required by A.R.S. §12-1518, except as may be required by other applicable statutes (Title 41).

12. Comments Welcome

The State Procurement Office periodically reviews the Uniform Terms and Conditions and welcomes any comments you may have. Please submit your comments to: State Procurement Administrator, State Procurement Office, 100 North 15th Avenue, Suite 201, Phoenix, Arizona, 85007.

STATE OF CALIFORNIA - ADDITIONAL TERMS

Terms and conditions listed below will be incorporated and made a part of California Participating Addenda. The State of California reserves the right to add additional terms and conditions to individual Participating Addenda.

A. Terms

- 1) General Provisions – Information Technology (GSPD-401IT) effective 9/5/2014. This document can be viewed on the DGS Procurement Division website (<https://www.dgs.ca.gov/PD/Resources/Page-Content/Procurement-Division-Resources-List-Folder/Model-Contract-Language>).

B. Administrative Fee

Contractor shall submit a check, payable to the State of California, remitted to the Cooperative Agreement Unit for the calculated amount equal to 1.25% of the sales for the quarterly period.

Contractor must include the Participating Addendum Number on the check. Those checks submitted to the State without the Participating Addendum Number will be returned to Contractor for additional identifying information.

Administrative fee checks shall be submitted to:

State of California
Department of General Services, Procurement Division
Attention: Cooperative Agreement Payment Processing
707 3rd Street, 2nd Floor, MS 2-202
West Sacramento, CA 95605

The administrative fee shall not be included as an adjustment to Contractor's NASPO ValuePoint Master Agreement pricing.

The administrative fee shall not be invoiced or charged to the ordering agency.

Payment of the administrative fee is due irrespective of payment status on orders or service contracts from a purchasing entity.

Administrative fee checks are due for each quarter as follows:

Reporting Period	Due Date
January 1 to March 31	April 30
April 1 to June 30	July 31
July 1 to September 30	October 31
October 1 to December 31	January 31

Failure to meet administrative fee requirements and submit fees on a timely basis shall constitute grounds for suspension of the Participating Addendum.



INSERT PORTFOLIO TITLE HERE
Led by the State of Insert State

Master Agreement #: enter number (*hereinafter "Master Agreement"*)

Contractor: enter **NAME (Contractor)** (*hereinafter "Contractor"*)

Participating State: **STATE OF HAWAII** (*hereinafter "Participating State"*)

State of Hawaii, State Procurement Office (SPO) Price List Contract No. insert VL/PL No.

This Addendum will add the State of Hawaii as a Participating State to purchase from the NASPO ValuePoint Master Agreement Number insert contract number with insert contractor name.

1. Scope: This addendum covers the [**contract title**] led by the State of [xxxxxx] for use by state agencies and other entities located in the Participating State of Hawaii authorized by that State's statutes to utilize State contracts.
2. Participation: All jurisdictions located within the State of Hawaii, which have obtained prior written approval by its Chief Procurement Officer, will be allowed to purchase from the Master Agreement. Private nonprofit health or human services organizations with current purchase of service contracts governed by Hawaii Revised Statutes (HRS) chapter 103F are eligible to participate in the SPO price/vendor list contracts upon mutual agreement between the Contractor and the non-profit. (Each such participating jurisdiction and participating nonprofit is hereinafter referred to as a "Participating Entity"). Issues of interpretation and eligibility for participation are solely within the authority of the Administrator, State Procurement Office.
3. Primary Contacts: The primary contact individuals for this Participating Addendum are as follows (or their named successors):

Contractor

Name:	Name
Address:	Address
Telephone:	Phone
Fax:	Fax
Email:	email



INSERT PORTFOLIO TITLE HERE
Led by the State of **insert State**

Participating State

Name:	Name of Purchasing Specialist
Address:	State Procurement Office 1151 Punchbowl Street, Room 416 Honolulu, HI 98613
Telephone:	Phone Number
Fax:	(808) 586-0540
Email:	Purchasing Specialist E-mail Address

4. Participating State Modifications or Additions to the Master Agreement: These modifications or additions apply only to actions and relationships within the Participating State and its Entities.

The following changes are modifying or supplementing the Master Agreement terms and conditions.

Changes:

- A. Usage Reports. Contractor shall submit a quarterly gross sales report (including zero-dollar sales) in EXCEL to the contact person listed in the Participating Addendum, Paragraph 3 (or as amended) in accordance with the following schedule (or as requested):

<u>Quarter Ending</u>	<u>Report Due</u>
March 31	April 30
June 30	July 31
September 30	October 31
December 31	January 31

The report shall identify each transaction and include the following information:

Department/Agency Name
Date of Purchase
Product/Service Description
Quantity
Unit of Measure
Item No. Part Number (if applicable)
MSRP List Price
NASPO ValuePoint Contract Price

INSERT PORTFOLIO TITLE HERE
Led by the State of insert State

The quarterly report shall also include any adjustment from prior periods (i.e. exchanges and/or return).

- B. The validity of this Addendum, any of its terms or provisions, as well as the right and duties of the parties in this Addendum, shall be governed by the laws of the State of Hawaii. A copy of the Attorney General's General Conditions, which is made a part of this Addendum, can be found at <https://spo.hawaii.gov/wp-content/uploads/2017/12/AG-008-103D-1.pdf>. Any action at law or in equity to enforce or interpret the provisions of this Addendum shall be brought in a court of competent jurisdiction in Honolulu, Hawaii.
- C. Inspection of Facilities. Pursuant to HRS § 103D-316, the Participating State, at reasonable times, may inspect the part of the plant or place of business of the Contractor or any subcontractor that is related to the performance of a Master Agreement and this Addendum.
- D. Campaign Contributions. The Contractor is notified of the applicability of HRS § 11-355, which prohibits campaign contributions from Contractor during the term of the Addendum if the contractor is paid with funds appropriated by the Hawaii State Legislature.
- E. Purchases by State of Hawaii government entities under this Master Agreement is not mandatory. This Addendum is secondary and non-exclusive.
- F. The State of Hawaii's purchasing card (pCard) is required to be used by the State's executive departments/agencies (excluding the Department of Education, the Hawaii Health System Corporation, the Office of Hawaiian Affairs, and the University of Hawaii) for all orders totaling less than \$2,500. For purchases of \$2,500 or more, agencies may use the pCard, subject to its credit limit or issue a purchase order.
- G. Pursuant to HRS §103D-310(c), if Contractor is doing business in the Participating State, Contractor is required to comply with all laws governing entities doing business in the Participating State, including the following HRS chapters.
 - 1. Chapter 237, General Excise Tax Law;
 - 2. Chapter 383, Hawaii Employment Security Law;
 - 3. Chapter 386, Workers' Compensation;
 - 4. Chapter 392, Temporary Disability Insurance;
 - 5. Chapter 393, Prepaid Health Care Act; and

A Certificate of Good Standing is required for entities doing business in the State.

The Hawaii Compliance Express (HCE) is utilized for verification of compliance. The SPO will conduct periodic checks to confirm Contractor's compliance on HCE throughout the term of the Addendum.



INSERT PORTFOLIO TITLE HERE

Led by the State of **insert State**

Alternatively, Contractors not utilizing HCE to demonstrate compliance shall provide paper certificates to the SPO as instructed below. All certificates must be valid on the date it is received by the SPO. All applications for applicable clearances are the responsibility of the Contractor.

HRS Chapter 237 tax clearance requirement. Pursuant to Section 103D-328, HRS, Contractor shall be required to submit a tax clearance certificate issued by the Hawaii State Department of Taxation (DOTAX) and the Internal Revenue Service (IRS). The certificate shall have an original green certified copy stamp and shall be valid for six (6) months from the most recent approval stamp date on the certificate.

The Tax Clearance Application, Form A-6, and its completion and filing instructions, are available on the DOTAX website: <http://tax.hawaii.gov/forms/>.

HRS Chapters 383 (Unemployment Insurance), 386 (Workers' Compensation), 392 (Temporary Disability Insurance), and 393 (Prepaid Health Care) requirements. Pursuant to Section 103D-310(c) Contractor shall be required to submit a certificate of compliance issued by the Hawaii State Department of Labor and Industrial Relations (DLIR). The certificate is valid for six (6) months from the date of issue. A photocopy of the certificate is acceptable to the SPO.

The DLIR Form LIR#27 Application for Certificate of Compliance with Section 3-122-112, HAR, and its filing instructions are available on the DLIR website: <http://labor.hawaii.gov/forms/>.

Compliance with Section 103D-310(c), HRS, for an entity doing business in the State. Contractor shall be required to submit a Certificate of Good Standing (COGS) issued by the State of Hawaii Department of Commerce and Consumer Affairs (DCCA) – Business Registration Division (BREG). The Certificate is valid for six (6) months from date of issue. A photocopy of the certificate is acceptable to the SPO.

To obtain the Certificate, the Contractor must be registered with the BREG. A sole proprietorship is not required to register with the BREG and is therefore not required to submit the certificate.

For more information regarding online business registration and the COGS is available at <http://cca.hawaii.gov/breg/>.

- H. Effective Date and Contract Period. This Addendum is effective upon the date of execution by the Participating State and shall continue for the term set forth in the Master Agreement.



INSERT PORTFOLIO TITLE HERE
Led by the State of **insert State**

I. Licensing

Contractors must be properly licensed and capable of performing the Work as described in the Master Agreement, in accordance with the Professional and Vocational licensing laws of the state. Contractors under Participating Addendums must maintain any and all required licenses through the duration of the contract and Participating Addendum.

J. Insurance

The Contractor shall maintain in full force and effect during the life of this contract, liability and property damage insurance to protect the Contractor and his Subcontractors, if any, from claims for damages for personal injury, accidental death and property damage which may arise from operations under this contract, whether such operations be by the Contractor or by Subcontractor or anyone directly or indirectly employed by either of them. If any Subcontractor is involved, the insurance policy or policies shall name the Subcontractor as additional insured.

As an alternative to the Contractor providing insurance to cover operations performed by a Subcontractor and naming the Subcontractor as additional insured, the Contractor may require the Subcontractor to provide its own insurance, which meets the requirements herein. It is understood that a Subcontractor's insurance policy or policies are in addition to the Contractor's own policy or policies.

The following minimum insurance coverage(s) and limit(s) shall be provided by the Contractor, including its Subcontractor(s) where appropriate.

<u>Coverage</u>	<u>Limits</u>
Commercial General Liability (occurrence form)	\$1,000,000 per occurrence \$2,000,000 aggregate
Automobile Liability	\$1,000,000 per accident
Professional Liability	\$1,000,000 per claim \$2,000,000 aggregate

Professional Liability shall be required from Contractors providing professional services requiring a license to conduct its business such as an engineer, architect, accountant, lawyer, information technology services etc. Use as applicable.

Cyber Liability covering claims and losses with respect to network, internet (Cloud) or other data disclosure risks (such as data breaches, releases of Confidential

INSERT PORTFOLIO TITLE HERE
Led by the State of **insert State**

Information, unauthorize access/use of information, and identity theft) within limits of not less than \$1,000,000 per claim and \$2,000,000 aggregate. – use as applicable

Each insurance policy required by this contract (with the exception of the Professional Liability policy-use as applicable), including a Subcontractor's policy, shall contain the following clauses:

- A. "The State of Hawaii is added as an additional insured as respects to operations performed for the State of Hawaii."
- B. "It is agreed that any insurance maintained by the State of Hawaii will apply in excess of, and not contribute with, insurance provided by this policy."

A Waiver of Subrogation shall apply to the General Liability, Automobile Liability and Worker's Compensation insurance policies and shall be in favor of the State of Hawaii.

The Contractor agrees to deposit with the State of Hawaii certificate(s) of insurance necessary to satisfy the State that the insurance provisions of this Addendum and have been complied with and to keep such insurance in effect and the certificate(s) therefore on deposit with the State during the entire term of the price/vendor list and price/vendor list extensions, if any, including those of its Subcontractor(s), where appropriate. Upon request by the State, Contractor shall be responsible for furnishing a copy of the policy or policies.

Failure of the Contractor to provide and keep in force such insurance shall be regarded as material default, entitling the State to exercise any or all of the remedies provided in the contract and this RFP for a default by the Contractor.

The procuring of such required insurance shall not be construed to limit the Contractor's liability hereunder nor to fulfill the indemnification provisions and requirements of this RFP. Notwithstanding said policy or policies of insurance, the Contractor shall be obliged for the full and total amount of any damage, injury, or loss caused by negligence or neglect connected with this price list.

- 5. Lease Agreements: Leasing is not authorized by this Addendum. Adjust as applicable.
- 6. Subcontractors: All contactors, dealers, and resellers authorized in the State of *[insert Lead State]*, as shown on the dedicated Contractor (cooperative contract) website, are approved to provide sales and service support to participants in the NASPO ValuePoint Master Agreement. The contractor's dealer participation will be in accordance with the terms and conditions set forth in the aforementioned Master Agreement. Subcontractors are (or are not) allowed under this Addendum.



INSERT PORTFOLIO TITLE HERE

Led by the State of **insert State**

7. Orders: Any order placed by a Participating Entity or Purchasing Entity for a product and/or service available from this Master Agreement shall be deemed to be a sale under (and governed by the prices and other terms and conditions) of the Master Agreement unless the parties to the order agree in writing that another contract or agreement applies to such order.

8. Freight Charges (unless otherwise stated in the master contract):

Prices proposed will be the delivered price to any state agency or political subdivision. All deliveries will be F.O.B. destination with all transportation and handling charges paid by the Contractor. Responsibility and liability for loss or damage will remain with Contractor until final inspection and acceptance when responsibility will pass to the Buyer except as to latent defects, fraud, and Contractor's warranty obligations. Any portion of a full order originally shipped without transportation charges (that failed to ship with the original order, thereby becoming back-ordered) will also be shipped without transportation charges.

9. Purchase Order and Payment Instructions:

All purchase orders issued by Participating Entities under this Addendum shall include the Participating State contract number: SPO Price List Contract No. add number and the NASPO ValuePoint Master Agreement Number add number.

Purchase Orders and Payments shall be made to add contractor name or authorized subcontractors, if any.

Invoices and Payment Instructions:

Contractor(s) shall forward original invoice(s), directly to the ordering agency. The GET or use tax and county surcharge may be added to the invoice as a separate line item and shall not exceed the current max pass-on tax rate(s) for each island.

County surcharges on state general excise (GE) tax or Use tax may be visibly passed on but is not required. For more information on county surcharges and the max pass-on tax rate, please visit the Department of Taxation's website at <http://tax.hawaii.gov/geninfo/countysurcharge>.

Pursuant to HRS § 103-10, Participating State and any agency of the Participating State or any county, shall have thirty (30) calendar days after receipt of invoice or satisfactory delivery of goods to make payment. Any interest for delinquent payment shall be as allowed by HRS § 103-10.

10. Participating Entity as Individual Customer:

Each Participating Entity shall be treated as an individual customer. Except to the extent modified by this Addendum, each Participating Entity will be responsible to follow the



INSERT PORTFOLIO TITLE HERE
 Led by the State of **insert State**

terms and conditions of the Master Agreement; and will have the same rights and responsibilities for their purchases as the Lead State has in the Master Agreement. Each Participating Entity will be responsible for its own charges, fees, and liabilities. Each Participating Entity will have the same rights to any indemnity or to recover any costs allowed in the Master Agreement for their purchases. The Contractor will apply the charges to each Participating Entity individually.

11. Entire Contract:

This Addendum, the Master Agreement, and the Attorney General's General Conditions, set forth the entire agreement, and all the conditions, understandings, promises, warranties and representations among the parties with respect to this Addendum and the Master Agreement, and supersedes any prior communications, representations or agreements whether, oral or written, with respect to the subject matter hereof.

Terms and conditions inconsistent with, contrary or in addition to the terms and conditions of this Addendum, the Master Agreement, and the Attorney General's General Conditions that are included in any purchase order or other document shall be void. The terms and conditions of this Addendum, the Master Agreement, and the Attorney General's General Conditions, shall govern in the case of any such inconsistent, contrary, or additional terms.

IN WITNESS WHEREOF, the parties have executed this Addendum as of the date of execution by both parties below.

Participating State: STATE OF HAWAII	Contractor:
Signature:	Signature:
Name: Bonnie Kahakui	Name:
Title: Acting Administrator, SPO	Title:
Date:	Date:



INSERT PORTFOLIO TITLE HERE
Led by the State of insert State

APPROVED AS TO FORM:

Deputy Attorney General

For questions on executing a participating addendum, please contact:

NASPO ValuePoint

Cooperative Development Coordinator:	Name
Telephone:	Phone
Email:	email

***[Please email fully executed PDF copy of this document to
PA@naspovaluepoint.org
to support documentation of participation and posting in appropriate data bases.]***

Cooperative Participation State of Illinois Specific Terms and Conditions

1. This participating agreement executed by the State of Illinois may be designated as available to all or certain governmental units and/or qualifying not for profit agencies. "Governmental unit" means State of Illinois, any State agency as defined in Section 1-15.100 of the Illinois Procurement Code (30 ILCS 500/), officers of the State of Illinois, any public authority which has the power to tax, or any other public entity created by statute. 30ILCS 525/.
2. In no event will the total term of any participating agreement, including the initial term and any extensions or amendments, exceed ten (10) years.
3. This participating agreement and all related public records maintained by, provided to, or required to be provided to the State, are subject to the Illinois Freedom of Information Act notwithstanding any provision to the contrary that may be found in this contract. 5 ILCS 140.
4. Any participating agreement executed by the State of Illinois is contingent upon and subject to the availability of funds. The State of Illinois, at its sole option, may terminate or suspend any participating agreement, in whole or in part, without penalty or further payment being required, if (1) the Illinois General Assembly or the Federal funding source fails to make an appropriation sufficient to pay such obligation, or if funds needed are insufficient for any reason (30 ILCS 500/20-60), (2) the Governor of Illinois decreases the Agency's funding by reserving some or all of the Agency's appropriation(s) pursuant to power delegated to the Governor by the Illinois General Assembly, that a reduction is necessary or advisable based upon actual or projected budgetary considerations. Vendor will be notified in writing of the failure of appropriation or of a reduction or decrease.
5. Any claim against any State of Illinois, any State of Illinois agency as defined in Section 1-15.100 of the Illinois Procurement Code (30 ILCS 500/), or officers of the State of Illinois arising out of any participating agreement must be filed exclusively with the Illinois Court of Claims. 705 ILCS 505/1. Payments, including late payment charges, will be paid in accordance with the State Prompt Payment Act and rules when applicable. 30 ILCS 540; 74 Ill. Adm. Code 900. This shall be Vendor's sole remedy for late payments by the State of Illinois. Payment terms contained in Vendor's invoices shall have no force or effect. The State of Illinois shall not enter into binding arbitration to resolve any dispute arising out of any participating agreement. The State of Illinois does not waive sovereign immunity.
6. Illinois may further evaluate the lead entity's awarded contracts to make best value determinations.
7. Registration in the Illinois Procurement Gateway is required before a participating agreement with the State of Illinois may be executed. For information on registration, please visit www.ipg.vendorreg.com.
8. Registration in BidBuy is required before a contract with the State of Illinois can be executed. For information on registration, please see the BidBuy [Vendor Registration Manual](#).
9. Any vendor with a participating agreement may be required to meet a Illinois Business Enterprise Program goal (30 ILCS 575/).

Title 21
STATE PROCUREMENT REGULATIONS

Subtitle 07 CONTRACT TERMS AND CONDITIONS

Chapter 01 Mandatory Contract Provisions — All Contracts (except as provided under COMAR 21.05.07, 21.07.02, and 21.07.03)

Authority: Election Law Article, §§14-101—14-108; General Provisions Article, §§5-101 and 5-503;
State Finance and Procurement Article, §§12-101, 13-211, 13-217—13-219, 13-221—13-223, 13-317, 16-202, 17-401, 17-402, and 19-114;
Annotated Code of Maryland; Chs. 588, 589, and 630, Acts of 2017

.01 Parties to the Contract.

Mandatory provision for all contracts.

.02 Scope of Contract.

Mandatory provision for all contracts. This provision shall reflect the unilateral right of the State to order in writing changes in the work within the scope of the contract.

.03 Compensation and Method of Payment.

Mandatory provision for all contracts. The contractor's taxpayer identification number consisting of the Social Security number for individuals and sole proprietors and the federal employer identification number for all other types of organizations shall be indicated in this clause.

.04 Contract Modifications.

Mandatory provision for all contracts.

.05 Non-Hiring of Officials and Employees.

Mandatory provision for all contracts: "No official or employee of the State of Maryland, as defined under General Provisions Article, §5-101, Annotated Code of Maryland, whose duties as such official or employee include matters relating to or affecting the subject matter of this contract, shall during the pendency and term of this contract and while serving as an official or employee of the State become or be an employee of the contractor or any entity that is a subcontractor on this contract."

.06 Disputes.

Mandatory provision for all contracts. One of the following clauses is preferred:

A. Alternate Disputes Clause (short form). "This contract shall be subject to the provisions of State Finance and Procurement Article, Title 15, Subtitle 2, Annotated Code of Maryland, and COMAR 21.10 (Administrative and Civil Remedies). Pending resolution of a claim, the Contractor shall proceed diligently with the performance of the contract in accordance with the procurement officer's decision."

B. Alternate Disputes Clause (long form).

"(1) This contract is subject to the provisions of State Finance and Procurement Article, Title 15, Subtitle 2, Annotated Code of Maryland and COMAR 21.10 (Administrative and Civil Remedies).

(2) Except as otherwise may be provided by law, all disputes arising under or as a result of a breach of this contract that are not disposed of by mutual agreement shall be resolved in accordance with this clause.

(3) As used herein, "claim" means a written demand or assertion by one of the parties seeking, as a legal right, the payment of money, adjustment or interpretation of contract terms, or other relief, arising under or relating to this contract. A voucher, invoice, or request for payment that is not in dispute when submitted is not a claim under this clause. However, if the submission subsequently is not acted upon in a reasonable time, or is disputed as to liability or amount, it may be converted to a claim for the purpose of this clause.

(4) A claim shall be made in writing and submitted to the procurement officer for decision in consultation with the Office of the Attorney General.

(5) When a claim cannot be resolved by mutual agreement, the contractor shall submit a written request for final decision to the procurement officer. The written request shall set forth all the facts surrounding the controversy.

(6) The contractor, at the discretion of the procurement officer, may be afforded an opportunity to be heard and to offer evidence in support of his claim.

STATE PROCUREMENT REGULATIONS

21.07.01.07

(7) The procurement officer shall render a written decision on all claims within 180 days of receipt of the contractor's written claim, unless the procurement officer determines that a longer period is necessary to resolve the claim. If a decision is not issued within 180 days, the procurement officer shall notify the contractor of the time within which a decision shall be rendered and the reasons for such time extension. The decision shall be furnished to the contractor, by certified mail, return receipt requested, or by any other method that provides evidence of receipt. The procurement officer's decision shall be deemed the final action of the State.

(8) The procurement officer's decision shall be final and conclusive unless the contractor mails or otherwise files a written appeal with the Maryland State Board of Contract Appeals within 30 days of receipt of the decision.

(9) Pending resolution of a claim, the contractor shall proceed diligently with the performance of the contract in accordance with the procurement officer's decision."

.07 Maryland Law Prevails.

Mandatory provision for all contracts unless otherwise authorized by the Board of Public Works.

.08 Nondiscrimination in Employment.

Mandatory provision for all contracts. The following clause is preferred:

"The Contractor agrees:(a) not to discriminate in any manner against an employee or applicant for employment because of race, color, religion, creed, age, sex, sexual orientation, gender identification, marital status, national origin, ancestry genetic information or any otherwise unlawful use of characteristics, or disability of a qualified individual with a disability unrelated in nature and extent so as to reasonably preclude the performance of the employment, or the individual's refusal to submit to a genetic test or make available the results of a genetic test; (b) to include a provision similar to that contained in subsection(a), above, in any underlying subcontract except a subcontract for standard commercial supplies or raw materials; and (c) to post and to cause subcontractors to post in conspicuous places available to employees and applicants for employment, notices setting forth the substance of this clause."

.09 Contingent Fee Prohibition.

Mandatory provision for all contracts:

"The contractor, architect, or engineer (as applicable) warrants that it has not employed or retained any person, partnership, corporation, or other entity, other than a bona fide employee or agent working for the contractor, architect, or engineer, to solicit or secure this agreement, and that it has not paid or agreed to pay any person, partnership, corporation, or other entity, other than a bona fide employee or agent, any fee or any other consideration contingent on the making of this agreement."

.10 Multi-Year Contracts Contingent Upon Appropriations.

Mandatory provision for all contracts and contract modifications to be effective in more than one fiscal year:

"If the General Assembly fails to appropriate funds or if funds are not otherwise made available for continued performance for any fiscal period of this Contract succeeding the first fiscal period, this Contract shall be cancelled automatically as of the beginning of the fiscal year for which funds were not appropriated or otherwise made available; provided, however, that this will not affect either the State's rights or the Contractor's rights under any termination clause in this Contract. The effect of termination of the Contract hereunder will be to discharge both the Contractor and the State from future performance of the Contract, but not from their rights and obligations existing at the time of termination. The Contractor shall be reimbursed for the reasonable value of any non-recurring costs incurred but not amortized in the price of the Contract. The State shall notify the Contractor as soon as it has knowledge that funds may not be available for the continuation of this Contract for each succeeding fiscal period beyond the first."

.11 Termination for Default.

Mandatory provision for all contracts. One of the following clauses is preferred:

A. Alternate Clause — Termination for Default (short form).

"If the Contractor fails to fulfill its obligation under this contract properly and on time, or otherwise violates any provision of the contract, the State may terminate the contract by written notice to the Contractor. The notice shall specify the acts or omissions relied upon as cause for termination. All finished or unfinished work provided by the Contractor shall, at the State's option, become the State's property. The State shall pay the Contractor fair and equitable compensation for satisfactory

CONTRACT TERMS AND CONDITIONS

21.07.01.11

performance prior to receipt of notice of termination, less the amount of damages caused by Contractor's breach. If the damages are more than the compensation payable to the Contractor, the Contractor will remain liable after termination and the State can affirmatively collect damages. Termination hereunder, including the determination of the rights and obligations of the parties, shall be governed by the provisions of COMAR 21.07.01.11B."

B. Alternate Clause — Termination for Default (long form).

"(1) The State may, subject to the provisions of paragraph (3) of this regulation, by written notice of default to the Contractor, terminate the whole or any part of this contract in any one of the following circumstances:(a) If the Contractor fails to perform within the time specified herein or any extension thereof; or (b) If the Contractor fails to perform any of the other provisions of this contract, or so fails to make progress as to endanger performance of this contract in accordance with its terms, and in either of these two circumstances does not cure such failure within a period of 10 days (or such longer period as the procurement officer may authorize in writing) after receipt of notice from the procurement officer specifying such failure.

"(2) In the event the State terminates this contract in whole or in part as provided in paragraph(1) of this clause, the State may procure substitute performance upon terms and in whatever manner the procurement officer may deem appropriate, and the Contractor shall be liable to the State for any excess costs for substitute performance; provided, that the Contractor shall continue the performance of this contract to the extent not terminated under the provisions of this clause.

"(3) Except with respect to defaults of subcontractors, the Contractor shall not be liable for any excess costs if the failure to perform the contract arises out of causes beyond the control and without the fault or negligence of the Contractor. Such causes may include, but are not restricted to, acts of God or of the public enemy, acts of the State in either its sovereign or contractual capacity, fires, floods, epidemics, quarantine restrictions, strikes, freight embargoes, and unusually severe weather; but in every case the failure to perform shall be beyond the control and without the fault or negligence of the Contractor. If the failure to perform is caused by the default of a subcontractor, and if the default arises out of causes beyond the control of both the Contractor and subcontractor, and without the fault or negligence of either of them, the Contractor shall not be liable for any excess costs for failure to perform unless substitute performance for the subcontractor was obtainable from another source in sufficient time to permit the Contractor to meet the performance schedule.

"(4) If, after notice of termination of this contract under the provisions of this clause, it is determined for any reason that the Contractor was not in default under the provisions of this clause, or that the default was excusable under the provisions of this clause, the rights and obligations of the parties shall, if the contract contains a clause providing for termination for convenience of the State, be the same as if the notice of termination had been issued pursuant to such clause. If, after notice of termination of this contract under the provisions of this clause, it is determined for any reason that the Contractor was not in default under the provisions of this clause, and if this contract does not contain a clause providing for termination for convenience of the State, the contract shall be equitably adjusted to compensate for such termination and the contract modified accordingly; failure to agree to any such adjustment shall be a dispute concerning a question of fact within the meaning of the clause of this contract entitled "Disputes."

"(5) If this contract is terminated as provided in paragraph(1) of this clause, the State, in addition to any other rights provided in this clause, may require the Contractor to transfer title and deliver to the State, in the manner, at the times, and to the extent, if any, directed by the procurement officer,(a) the fabricated or unfabricated parts, work in progress, completed work, supplies, and other material produced as a part of, or acquired in connection with the performance of, the work terminated by the Notice of Termination, and (b) the completed or partially completed plans, drawings, information, and other property which, if the contract had been completed, would have been required to be furnished to the State; and the Contractor shall, upon direction of the procurement officer, protect and preserve property in the possession of the Contractor in which the State has an interest. Payment for completed supplies delivered to and accepted by the State shall be at the contract price. Payment for manufacturing materials delivered to and accepted by the State and for the protection and preservation of property shall be in an amount agreed upon by the Contractor and procurement officer; failure to agree to such amount shall be a dispute concerning a question of fact within the meaning of the clause of this contract entitled "Disputes." The State may withhold from amounts otherwise due the Contractor hereunder such sum as the procurement officer determines to be necessary to protect the State against loss because of outstanding liens or claims of former lien holders.

"(6) The rights and remedies of the State provided in this clause shall not be exclusive and are in addition to any other rights and remedies provided by law or under this contract.

STATE PROCUREMENT REGULATIONS

21.07.01.12

"(7) As used in paragraph (3) of this clause, the terms, "subcontractor" and "subcontractors" mean subcontractor(s) at any tier."

.12 Termination for Convenience.

A. Except as provided in §B of this regulation, mandatory provision for all contracts. One of the following clauses is preferred:

(1) Alternate Clause — Termination for Convenience (short form).

"The performance of work under this contract may be terminated by the State in accordance with this clause in whole, or from time to time in part, whenever the State shall determine that such termination is in the best interest of the State. The State will pay all reasonable costs associated with this contract that the Contractor has incurred up to the date of termination and all reasonable costs associated with termination of the Contract. However, the Contractor shall not be reimbursed for any anticipatory profits that have not been earned up to the date of termination. Termination hereunder, including the determination of the rights and obligations of the parties, shall be governed by the provisions of COMAR 21.07.01.12A(2)."

(2) Alternate Clause — Termination for Convenience (long form).

"(1) The performance of work under this contract may be terminated by the State in accordance with this clause in whole, or from time to time in part, whenever the State shall determine that such termination is in the best interest of the State. Any such termination shall be effected by delivery to the Contractor of a Notice of Termination specifying the extent to which performance of work is terminated and the time when such termination becomes effective.

"(2) After receipt of a Notice of Termination, and except as otherwise directed by the procurement officer, the Contractor shall:

(a) stop work as specified in the Notice of Termination;

(b) place no further orders or subcontracts for materials, services or facilities, except as may be necessary for completion of the portion of the work under the contract as is not terminated;

(c) terminate all orders and subcontracts to the extent that they relate to the performance of work terminated by the Notice of Termination;

(d) assign to the State, in the manner, at times, and to the extent directed by the procurement officer, all of the right, title, and interest of the Contractor under the orders and subcontracts so terminated, in which case the State shall have the right, in its discretion, to settle or pay any or all claims arising out of the termination of such orders and subcontracts;

(e) settle all outstanding liabilities and all claims arising out of such termination of orders and subcontracts, with the approval or ratification of the procurement officer, to the extent he may require, which approval or ratification shall be final for all the purposes of this clause;

(f) transfer title and deliver to the State, in the manner, at the times, and to the extent, if any, directed by the procurement officer, (i) the fabricated or unfabricated parts, work in process, completed work, supplies, and other material produced as a part of, or acquired in connection with the performance of, the work terminated by the Notice of Termination, and (ii) the completed or partially completed plans, drawings, information, and other property which, if the contract had been completed, would have been required to be furnished to the State;

(g) use its best efforts to sell, in the manner, at the times, to the extent, and at the price or prices directed or authorized by the procurement officer, any property of the types referred to in (f) above; provided, however, that the Contractor (i) may not be required to extend credit to any purchaser, and (ii) may acquire any such property under the conditions prescribed by and at a price or prices approved by the procurement officer; and provided further that the proceeds of any such transfer or disposition shall be applied in reduction of any payments to be made by the State to the Contractor under this contract or shall otherwise be credited to the price or cost of the work covered by this contract or paid in such other manner as the procurement officer may direct;

(h) complete performance of such part of the work as shall not have been terminated by the Notice of Termination; and

(i) take any action that may be necessary, or as the procurement officer may direct, for the protection and preservation of the property related to this contract which is in the possession of the Contractor and in which the State has or may acquire an interest.

CONTRACT TERMS AND CONDITIONS

21.07.01.12

The Contractor shall submit to the procurement officer a list, certified as to quantity and quality, of any or all items of termination inventory not previously disposed of, exclusive of items the disposition of which has been directed or authorized by the procurement officer, and may request the State to remove them or enter into a storage agreement covering them. Not later than fifteen (15) days thereafter, the State shall accept title to these items and remove them or enter into a storage agreement covering the same; provided, that the list submitted shall be subject to verification by the procurement officer upon removal of the items, or if the items are stored, within forty-five (45) days from the date of submission of the list, and any necessary adjustment to correct the list as submitted shall be made before final settlement.

"(3) After receipt of a Notice of Termination, the Contractor shall submit to the procurement officer his termination claim, in the form and with certification prescribed by the procurement officer. This claim shall be submitted promptly but in no event later than one(1) year from the effective date of termination, unless one or more extensions in writing are granted by the procurement officer, upon request of the Contractor made in writing within the one-year period or authorized extension thereof. However, if the procurement officer determines that the facts justify such action, he may receive and act upon any such termination claim at any time after the one-year period or any extension thereof. Upon failure of the Contractor to submit his termination claim within the time allowed, the procurement officer may determine the claim at any time after the one-year period or any extension thereof. Upon failure of the Contractor to submit his termination claim within the time allowed, the procurement officer may determine, on the basis of information available to him, the amount, if any, due to the Contractor by reason of the termination and shall thereupon pay to the Contractor the amount so determined.

"(4) Subject to the provisions of paragraph (3), the Contractor and the procurement officer may agree upon the whole or any part of the amount or amounts to be paid to the Contractor by reason of the total or partial termination of work pursuant to this clause, which amount or amounts may include a reasonable allowance for profit on work done; provided, that such agreed amount or amounts, exclusive of settlement costs, shall not exceed the total contract price as reduced by the amount of payments otherwise made and as further reduced by the contract price of work not terminated. The contract shall be amended accordingly, and the Contractor shall be paid the agreed amount. Nothing in paragraph (5) of this clause, prescribing the amount to be paid to the Contractor in the event of failure of the Contractor and the procurement officer to agree upon the whole amount to be paid to the Contractor by reason of the termination of work pursuant to this clause, shall be deemed to limit, restrict, or otherwise determine or affect the amount or amounts that may be agreed upon to be paid to the Contractor pursuant to this paragraph.

"(5) In the event of the failure of the Contractor and the procurement officer to agree as provided in paragraph (4) upon the whole amount to be paid to the Contractor by reason of the termination of work pursuant to this clause, the procurement officer shall pay to the Contractor the amounts determined by the procurement officer as follows, but without duplication of any amounts agreed upon in accordance with paragraph (4):

(a) for completed supplies or services accepted by the State (or sold or acquired as provided in paragraph (2)(g) above) and for which payment has not theretofore been made, a sum equivalent to the aggregate price for the supplies or services computed in accordance with the price or prices specified in the contract, appropriately adjusted for any saving of freight or other charges;

(b) the total of:

(i) the costs incurred in the performance of the work terminated, including initial costs and preparatory expense allocable thereto, but exclusive of any costs attributable to supplies or services paid or to be paid for under paragraph (5)(a) hereof;

(ii) the cost of settling and paying claims arising out of the termination of work under subcontracts or orders, as provided in paragraph (2)(e) above, which are properly chargeable to the terminated portion of the contract (exclusive of amounts paid or payable on account of supplies or materials delivered or services furnished by subcontractors or vendors before the effective date of the Notice of Termination, which amounts shall be included in the costs payable under(i) above); and

(iii) a sum, as profit on(i) above, determined by the procurement officer to be fair and reasonable; provided, however, that if it appears that the contractor would have sustained a loss on the entire contract had it been completed, no profit shall be included or allowed under this subdivision (iii) and an appropriate adjustment shall be made reducing the amount of the settlement to reflect the indicated rate of loss; and

(c) the reasonable cost of settlement accounting, legal, clerical, and other expenses reasonably necessary for the preparation of settlement claims and supporting data with respect to the terminated portion of the contract and for the termination

STATE PROCUREMENT REGULATIONS

21.07.01.12

and settlement of subcontracts thereunder, together with reasonable storage, transportation, and other costs incurred in connection with the protection or disposition of property allocable to this contract.

The total sum to be paid to the Contractor under(a) and (b) of this paragraph shall not exceed the total contract price as reduced by the amount of payments otherwise made and as further reduced by the contract price of work not terminated. Except for normal spoilage, and except to the extent that the State shall have otherwise expressly assumed the risk of loss, there shall be excluded from the amounts payable to the Contractor as provided in (5)(a) and (b)(i) above, the fair value, as determined by the procurement officer, of property that is destroyed, lost, stolen, or damaged so as to become undeliverable to the State or to a buyer pursuant to paragraph (2)(g).

"(6) Costs claimed, agreed to, or determined pursuant to (3), (4), (5) and (11) hereof shall be in accordance with COMAR 21.09 (Contract Cost Principles and Procedures) as in effect on the date of this contract.

"(7) The Contractor shall have the right of appeal, under the clause of this contract entitled "Disputes," from any determination made by the procurement officer under paragraph (3), (5), or (9) hereof, except that if the Contractor has failed to submit his claim within the time provided in paragraph (3) or (9) hereof, and has failed to request extension of the time, he shall have no right of appeal. In any case where the procurement officer has made a determination of the amount due under paragraph (3), (5), or (9) hereof, the State shall pay to the Contractor the following:(a) if there is no right of appeal hereunder or if no timely appeal has been taken, the amount so determined by the procurement officer, or (b) if an appeal has been taken, the amount finally determined on such appeal.

"(8) In arriving at the amount due the Contractor under this clause there shall be deducted(a) all unliquidated advance or other payments on account theretofore made to the Contractor, applicable to the terminated portion of this contract, (b) any claim which the State may have against the Contractor in connection with this contract, and (c) the agreed price for, or the proceeds of sale of, any materials, supplies, or other things acquired by the Contractor or sold, pursuant to the provisions of this clause, and not otherwise recovered by or credited to the State.

"(9) If the termination hereunder be partial, the Contractor may file with the procurement officer a claim for an equitable adjustment of the price or prices specified in the contract relating to the continued portion of the contract (the portion not terminated by the Notice of Termination), and such equitable adjustment as may be agreed upon shall be made in such price or prices. Any claim by the Contractor for an equitable adjustment under this clause shall be asserted within ninety (90) days from the effective date of the termination notice, unless an extension is granted in writing by the procurement officer.

"(10) The State may from time to time, under such terms and conditions as it may prescribe, make partial payments and payments on account against costs incurred by the Contractor in connection with the terminated portion of this contract whenever in the opinion of the procurement officer the aggregate of such payments shall be within the amount to which the Contractor shall be entitled hereunder. If the total of such payments is in excess of the amount finally agreed or determined to be due under this clause, such excess shall be payable by the Contractor to the State upon demand, together with interest computed at the prime rate established by the State Treasurer for the period from the date such excess payment is received by the Contractor to the date on which such excess is repaid to the State; provided, however, that no interest shall be charged with respect to any such excess payment attributable to a reduction in the Contractor's claim by reason of retention or other disposition of termination inventory until ten days after the date of such retention or disposition, or a later date as determined by the procurement officer by reason of the circumstances.

"(11) Unless otherwise provided for in this contract, or by applicable statute, the Contractor shall—from the effective date of termination until the expiration of three years after final settlement under this contract—preserve and make available to the State at all reasonable times at the office of the Contractor but without direct charge to the State, all his books, records, documents and other evidence bearing on the costs and expenses of the Contractor under this contract and relating to the work terminated hereunder, or, to the extent approved by the procurement officer, reproductions thereof."

B. Leases of Real Property.

(1) Inclusion of a termination for convenience clause in a real property lease is discretionary with the Board of Public Works, upon recommendation of the Secretary of General Services.

(2) In recommending the exclusion of a termination for convenience clause in a real property lease, the Secretary shall consider such factors as:

CONTRACT TERMS AND CONDITIONS

21.07.01.18

(a) The practicality of including the termination for convenience clause in a lease of real property located in another state or overseas when the demand for property of a particular type or in some particular geographic location is extremely intense, or when the contents of a lease are established by a foreign government and are effectively non-negotiable, or both;

(b) The perception of some landlords that the termination for convenience clause permits the State to unilaterally convert a fixed term lease to a day-to-day lease; or

(c) The prospects that some lending institutions may reject loan requests from landlords owning property that the State might wish to lease but that must be first upgraded at the owner's expense to meet State User Agency Requirements.

.13 Delays and Extensions of Time.

Mandatory provision for all contracts. It shall be in substantially the same form as follows:

"Delays and Extensions of Time"

"The Contractor agrees to prosecute the work continuously and diligently and no charges or claims for damages shall be made by it for any delays or hindrances from any cause whatsoever during the progress of any portion of the work specified in this Contract.

"Time extensions will be granted only for excusable delays that arise from unforeseeable causes beyond the control and without the fault or negligence of the Contractor, including but not restricted to, acts of God, acts of the public enemy, acts of the State in either its sovereign or contractual capacity, acts of another Contractor in the performance of a contract with the State, fires, floods, epidemics, quarantine restrictions, strikes, freight embargoes, or delays of subcontractors or suppliers arising from unforeseeable causes beyond the control and without the fault or negligence of either the Contractor or the subcontractors or suppliers."

.14 Liquidated Damages.

Mandatory provision for:

A. All contracts with certified MBE participation goals in accordance with COMAR 21.11.03.10E; and

B. Any other contracts deemed appropriate by the procurement officer in consultation with the Office of the Attorney General.

.15 Variations in Estimated Quantities.

Mandatory provision for all contracts that contain estimated quantity items.

.16 Suspension of Work.

Mandatory provision for all contracts. It shall be in substantially the same form as follows:

"The procurement officer unilaterally may order the Contractor in writing to suspend, delay, or interrupt all or any part of the work for such period of time as he may determine to be appropriate for the convenience of the State."

.17 Pre-existing Regulations.

Mandatory provision for all contracts. It shall be in substantially the same form as follows:

"In accordance with the provisions of §11-206 of the State Finance and Procurement Article, Annotated Code of Maryland, the regulations set forth in Title 21 of the Code of Maryland Regulations (COMAR Title 21) in effect on the date of execution of this Contract are applicable to this Contract."

.18 Payment of State Obligations.

Mandatory provision for all contracts. The following clause is preferred:

"Unless a payment is unauthorized, deferred, delayed, or set-off under COMAR 21.02.07, Payments to the Contractor pursuant to this Contract shall be made no later than 30 days after the State's receipt of a proper invoice from the Contractor.

The Contractor may be eligible to receive late payment interest at the rate of 9% per annum if:

(1) The Contractor submits an invoice for the late payment interest within thirty days after the date of the State's payment of the amount on which the interest accrued; and

(2) A contract claim has not been filed under State Finance and Procurement Article, Title 15, Subtitle 2, Annotated Code of Maryland.

STATE PROCUREMENT REGULATIONS

21.07.01.19

The State is not liable for interest:

- (1) Accruing more than one year after the 31st day after the agency receives the proper invoice; or
- (2) On any amount representing unpaid interest. Charges for late payment of invoices are authorized only as prescribed by Title 15, Subtitle 1, of the State Finance and Procurement Article, Annotated Code of Maryland, or by the Public Service Commission of Maryland with respect to regulated public utilities, as applicable."

.19 Financial Disclosure.

Mandatory provision for all contracts:

"The Contractor shall comply with the provisions of State Finance and Procurement Article §13-221, Annotated Code of Maryland. That section requires a business to file with the Secretary of State of Maryland certain specified information, including disclosure of beneficial ownership of the business, within 30 days of the date the aggregate value of any contracts, leases, or other agreements that the business enters into with the State of Maryland or its agencies during a calendar year reaches \$200,000."

.20 Political Contribution Disclosure.

Mandatory provision for all contracts:

"The Contractor shall comply with Election Law Article, Title 14, Annotated Code of Maryland, which requires that every person that enters into a procurement contract with the State, a county, or a municipal corporation, or other political subdivision of the State, during a calendar year in which the person receives a contract with a governmental entity in the amount of \$200,000 or more, shall file with the State Board of Elections statements disclosing:(a) any contributions made during the reporting period to a candidate for elective office in any primary or general election; and (b) the name of each candidate to whom one or more contribution in a cumulative amount of \$500 or more were made during the reporting period. The statement shall be filed with the State Board of Elections:(a) before execution of a contract by the State, a county, a municipal corporation, or other political subdivision of the State, and shall cover the 24 months prior to when a contract was awarded; and (b) if the contribution is made after the execution of a contract, then twice a year, throughout the contract term, on or before:(i) May 31, to cover the six (6) month period ending April 30; and (ii) November 30, to cover the six (6) month period ending October 31. Additional information is available on the State Board of Election website: http://www.elections.state.md.us/campaign_finance/index.html."

.21 Retention of Records.

Mandatory provision for all contracts. The following clause is preferred:

"The Contractor shall retain and maintain all records and documents relating to this Contract for three years after final payment by the State hereunder or any applicable statute of limitations, whichever is longer, and shall make them available for inspection and audit by authorized representatives of the State, including the procurement officer or designee, at all reasonable times."

.22 Compliance with Laws.

Mandatory provision for all contracts. The following clause is preferred:

"The Contractor hereby represents and warrants that:

"A. It is qualified to do business in the State of Maryland and that it will take such action as, from time to time hereafter, may be necessary to remain so qualified;

"B. It is not in arrears with respect to the payment of any monies due and owing the State of Maryland, or any department or unit thereof, including but not limited to the payment of taxes and employee benefits, and that it shall not become so in arrears during the term of this Contract;

"C. It shall comply with all federal, State, and local laws, regulations, and ordinances applicable to its activities and obligations under this Contract; and

"D. It shall obtain, at its expense, all licenses, permits, insurance, and governmental approvals, if any, necessary to the performance of its obligations under this Contract."

.23 Cost and Price Certification.

Mandatory provision for all contracts and contract modifications (excluding real property leases and architectural services or engineering services contracts (see Regulation .24)) if the contract or modification exceeds \$100,000 or a smaller amount

CONTRACT TERMS AND CONDITIONS

21.07.01.25

determined by the procurement officer under State Finance and Procurement Article, §13-220. The language shall be in substantially the same form as follows:

"Cost and Price Certification"

"A. The Contractor by submitting cost or price information certifies that, to the best of its knowledge, the information submitted is accurate, complete, and current as of a mutually determined specified date prior to the conclusion of any price discussions or negotiations for:

"(1) A negotiated contract, if the total contract price is expected to exceed \$100,000, or a smaller amount set by the procurement officer; or

"(2) A change order or contract modification, expected to exceed \$100,000, or a smaller amount set by the procurement officer.

"B. The price under this Contract and any change order or modification hereunder, including profit or fee, shall be adjusted to exclude any significant price increases occurring because the Contractor furnished cost or price information which, as of the date agreed upon between the parties, was inaccurate, incomplete, or not current."

.24 Truth-In-Negotiation Certification.

Mandatory provision for architectural services or engineering services contracts exceeding \$100,000. It shall be in substantially the same form as follows:

"Truth-In-Negotiation Certification"

"The Contractor by submitting cost or price information, including wage rates or other factual unit costs, certifies to the best of its knowledge, information and belief, that:

"A. The wage rates and other factual unit costs supporting the firm's compensation, as set forth in the proposal, are accurate, complete and current as of the contract date;

"B. If any of the items of compensation were increased due to the furnishing of inaccurate, incomplete or noncurrent wage rates or other units of costs, the State is entitled to an adjustment in all appropriate items of compensation, including profit or fee, to exclude any significant sum by which the price was increased because of the defective data. The State's right to adjustment includes the right to a price adjustment for defects in costs or pricing data submitted by a prospective or actual subcontractor; and

"C. If additions are made to the original price of the contract, such additions may be adjusted to exclude any significant sums where it is determined the price has been increased due to inaccurate, incomplete or noncurrent wage rates and other factual costs."

.25 Contract Affidavit.

Mandatory contract addendum. The contract addendum shall be in substantially the same form as follows and submitted upon initial award and each renewal thereafter:

A. AUTHORITY

I HEREBY AFFIRM THAT:

I, (print name) _____ possess the legal authority to make this Affidavit.

B. CERTIFICATION OF REGISTRATION OR QUALIFICATION WITH THE STATE DEPARTMENT OF ASSESSMENTS AND TAXATION

I FURTHER AFFIRM THAT:

The business named above is a (check applicable items):

- (1) Corporation — domestic or foreign;
- (2) Limited Liability Company — domestic or foreign;
- (3) Partnership — domestic or foreign;
- (4) Statutory Trust — domestic or foreign;
- (5) Sole Proprietorship

STATE PROCUREMENT REGULATIONS

21.07.01.25

and is registered or qualified as required under Maryland Law.

I further affirm that the above business is in good standing both in Maryland and (IF APPLICABLE) in the jurisdiction where it is presently organized, and has filed all of its annual reports, together with filing fees, with the Maryland State Department of Assessments and Taxation. The name and address of its resident agent (IF APPLICABLE) filed with the State Department of Assessments and Taxation is:

Name and Department ID

Number: _____ Address: _____

and that if it does business under a trade name, it has filed a certificate with the State Department of Assessments and Taxation that correctly identifies that true name and address of the principal or owner as:

Name and Department ID Number: _____

Address: _____

C. FINANCIAL DISCLOSURE AFFIRMATION

I FURTHER AFFIRM THAT:

I am aware of, and the above business will comply with, the provisions of State Finance and Procurement Article, §13-221, Annotated Code of Maryland, which require the business to file with the Secretary of State of Maryland certain specified information, including disclosure of beneficial ownership of the business, within 30 days of the date the aggregate value of any contracts, leases, or other agreements that the business enters into with the State of Maryland or its agencies during a calendar year reaches \$200,000.

D. POLITICAL CONTRIBUTION DISCLOSURE AFFIRMATION

I FURTHER AFFIRM THAT:

I am aware of, and the above business will comply with, Election Law Article, Title 14, Annotated Code of Maryland, which requires that every person that enters into a procurement contract with the State, a county, a municipal corporation, or other political subdivision of the State, during a calendar year in which the person receives a contract with a governmental entity in the amount of \$200,000 or more shall file with the State Board of Elections statements disclosing: (a) any contributions made during the reporting period to a candidate for elective office in any primary or general election; and (b) the name of each candidate to whom one or more contributions in a cumulative amount of \$500 or more were made during the reporting period. The statement shall be filed with the State Board of Elections: (a) before execution of a contract by the State, a county, a municipal corporation, or other political subdivision of the State, and shall cover the 24 months prior to when a contract was awarded; and (b) if the contribution is made after the execution of a contract, then twice a year, throughout the contract term, on: (i) May 31, to cover the six (6) month period ending April 30; and (ii) November 30, to cover the six (6) month period ending October 31.

E. DRUG AND ALCOHOL FREE WORKPLACE

(Applicable to all contracts unless the contract is for a law enforcement agency and the agency head or the agency head's designee has determined that application of COMAR 21.11.08 and this certification would be inappropriate in connection with the law enforcement agency's undercover operations.)

I CERTIFY THAT:

- (1) Terms defined in COMAR 21.11.08 shall have the same meanings when used in this certification.
- (2) By submission of its bid or offer, the business, if other than an individual, certifies and agrees that, with respect to its employees to be employed under a contract resulting from this solicitation, the business shall:
 - (a) Maintain a workplace free of drug and alcohol abuse during the term of the contract;
 - (b) Publish a statement notifying its employees that the unlawful manufacture, distribution, dispensing, possession, or use of drugs, and the abuse of drugs or alcohol is prohibited in the business' workplace and specifying the actions that will be taken against employees for violation of these prohibitions;
 - (c) Prohibit its employees from working under the influence of drugs or alcohol;

CONTRACT TERMS AND CONDITIONS

21.07.01.25

(d) Not hire or assign to work on the contract anyone who the business knows, or in the exercise of due diligence should know, currently abuses drugs or alcohol and is not actively engaged in a bona fide drug or alcohol abuse assistance or rehabilitation program;

(e) Promptly inform the appropriate law enforcement agency of every drug-related crime that occurs in its workplace if the business has observed the violation or otherwise has reliable information that a violation has occurred;

(f) Establish drug and alcohol abuse awareness programs to inform its employees about:

(i) The dangers of drug and alcohol abuse in the workplace;

(ii) The business's policy of maintaining a drug and alcohol free workplace;

(iii) Any available drug and alcohol counseling, rehabilitation, and employee assistance programs; and

(iv) The penalties that may be imposed upon employees who abuse drugs and alcohol in the workplace;

(g) Provide all employees engaged in the performance of the contract with a copy of the statement required by §E(2)(b), of this regulation;

(h) Notify its employees in the statement required by §E(2)(b), of this regulation, that as a condition of continued employment on the contract, the employee shall:

(i) Abide by the terms of the statement; and

(ii) Notify the employer of any criminal drug or alcohol abuse conviction for an offense occurring in the workplace not later than 5 days after a conviction;

(i) Notify the procurement officer within 10 days after receiving notice under §E(2)(h)(ii), of this regulation, or otherwise receiving actual notice of a conviction;

(j) Within 30 days after receiving notice under §E(2)(h)(ii), of this regulation, or otherwise receiving actual notice of a conviction, impose either of the following sanctions or remedial measures on any employee who is convicted of a drug or alcohol abuse offense occurring in the workplace:

(i) Take appropriate personnel action against an employee, up to and including termination; or

(ii) Require an employee to satisfactorily participate in a bona fide drug or alcohol abuse assistance or rehabilitation program;

and

(k) Make a good faith effort to maintain a drug and alcohol free workplace through implementation of §E(2)(a)—(j), of this regulation.

(3) If the business is an individual, the individual shall certify and agree as set forth in §E(4), of this regulation, that the individual shall not engage in the unlawful manufacture, distribution, dispensing, possession, or use of drugs or the abuse of drugs or alcohol in the performance of the contract.

(4) I acknowledge and agree that:

(a) The award of the contract is conditional upon compliance with COMAR 21.11.08 and this certification;

(b) The violation of the provisions of COMAR 21.11.08 or this certification shall be cause to suspend payments under, or terminate the contract for default under COMAR 21.07.01.11 or 21.07.03.15, as applicable; and

(c) The violation of the provisions of COMAR 21.11.08 or this certification in connection with the contract may, in the exercise of the discretion of the Board of Public Works, result in suspension and debarment of the business under COMAR 21.08.03.

STATE PROCUREMENT REGULATIONS

21.07.01.26

F. CERTAIN AFFIRMATIONS VALID

I FURTHER AFFIRM THAT:

To the best of my knowledge, information, and belief, each of the affirmations, certifications, or acknowledgements contained in that certain Bid/Proposal Affidavit dated _____, 20____, and executed by me for the purpose of obtaining the contract to which this Exhibit is attached remains true and correct in all respects as if made as of the date of this Contract Affidavit and as if fully set forth herein.

I DO SOLEMNLY DECLARE AND AFFIRM UNDER THE PENALTIES OF PERJURY THAT THE CONTENTS OF THIS AFFIDAVIT ARE TRUE AND CORRECT TO THE BEST OF MY KNOWLEDGE, INFORMATION, AND BELIEF.

Date: _____

By: _____ (printed name of Authorized Representative and affiant)

_____ (signature of Authorized Representative and affiant)

.26 Commercial Nondiscrimination Clause.

A. The following provision is mandatory for all State contracts and subcontracts: "As a condition of entering into this Agreement, Contractor represents and warrants that it will comply with the State's Commercial Nondiscrimination Policy, as described under Title 19 of the State Finance and Procurement Article of the Annotated Code of Maryland. As part of such compliance, Contractor may not discriminate on the basis of race, color, religion, ancestry, national origin, sex, age, marital status, sexual orientation, sexual identity, genetic information or an individual's refusal to submit to a genetic test or make available the results of a genetic test or on the basis of disability, or other unlawful forms of discrimination in the solicitation, selection, hiring, or commercial treatment of subcontractors, vendors, suppliers, or commercial customers, nor shall Contractor retaliate against any person for reporting instances of such discrimination. Contractor shall provide equal opportunity for subcontractors, vendors, and suppliers to participate in all of its public sector and private sector subcontracting and supply opportunities, provided that this clause does not prohibit or limit lawful efforts to remedy the effects of marketplace discrimination that have occurred or are occurring in the marketplace. Contractor understands that a material violation of this clause shall be considered a material breach of this Agreement and may result in termination of this Agreement, disqualification of Contractor from participating in State contracts, or other sanctions. This clause is not enforceable by or for the benefit of, and creates no obligation to, any third party.

B. The following provision is mandatory for all State contracts: "As a condition of entering into this Agreement, upon the request of the Commission on Civil Rights, and only after the filing of a complaint against Contractor under Title 19 of the State Finance and Procurement Article of the Annotated Code of Maryland, as amended from time to time, Contractor agrees to provide within 60 days after the request a complete list of the names of all subcontractors, vendors, and suppliers that Contractor has used in the past 4 years on any of its contracts that were undertaken within the State of Maryland, including the total dollar amount paid by Contractor on each subcontract or supply contract. Contractor further agrees to cooperate in any investigation conducted by the State pursuant to the State's Commercial Nondiscrimination Policy as set forth under Title 19 of the State Finance and Procurement Article of the Annotated Code of Maryland, and to provide any documents relevant to any investigation that are requested by the State. Contractor understands that violation of this clause is a material breach of this Agreement and may result in contract termination, disqualification by the State from participating in State contracts, and other sanctions."

.27 Performance and Payment Bonds.

This regulation is added as a separate pdf form within this chapter.

.27 Performance and Payment Bonds.

Mandatory provision for contracts exceeding \$100,000 with surety bond requirements:

A. Performance Bond. The required performance bond shall be in the form specified as follows:

PERFORMANCE BOND

Principal	Business Address of Principal
Surety	Obligee
a corporation of the State of _____	STATE OF MARYLAND
and authorized to do business in the State of Maryland	
Penal Sum of Bond (express in words and figures)	Date of Contract
_____	_____, 20____
Description of Contract	Date Bond Executed
_____	_____, 20____
Contract Number: _____	

KNOW ALL BY THESE PRESENTS, That we, the Principal named above and Surety named above, are held and firmly bound unto the Obligee named above in the Penal Sum of this Performance Bond stated above, for the payment of which Penal Sum we bind ourselves, our heirs, executors, administrators, personal representatives, successors, and assigns, jointly and severally, firmly by these presents. However, where Surety is composed of corporations acting as co-sureties, we the co-sureties, bind ourselves, our successors and assigns, in such Penal Sum jointly and severally as well as severally only for the purpose of allowing a joint action or actions against any or all of us, and for all other purposes each co-surety binds itself, jointly and severally with the Principal, for the payment of such sum as appears above its name below, but if no limit of liability is indicated, the limit of such liability shall be the full amount of the Penal Sum.

WHEREAS, Principal has entered into or will enter into a contract with the State of Maryland, by and through the Administration named above acting for the State of Maryland, which contract is described and dated as shown above, and incorporated herein by reference. The contract and all items incorporated into the contract, together with any and all changes, extensions of time, alterations, modifications, or additions to the contract or to the work to be performed thereunder or to the Plans, Specifications, and Special Provisions, or any of them, or to any other items incorporated into the contract shall hereinafter be referred as "the Contract."

WHEREAS, it is one of the conditions precedent to the final award of the Contract that these presents be executed.

NOW, THEREFORE, during the original term of said Contract, during any extensions thereto that may be granted by the Administration, and during the guarantee and warranty period, if any, required under the Contract, unless otherwise stated therein, this Performance Bond shall remain in full force and effect unless and until the following terms and conditions are met:

1. Principal shall well and truly perform the Contract; and
2. Principal and Surety shall comply with the terms and conditions in this Performance Bond.

Whenever Principal shall be declared by the Administration to be in default under the Contract, the Surety may, within 15 days after notice of default from the Administration, notify the Administration of its election to either promptly proceed to remedy the default or promptly proceed to complete the contract in accordance with and subject to its terms and conditions. In the event the Surety does not elect to exercise either of the above stated options, then the Administration thereupon shall have the remaining contract work completed, Surety to remain liable hereunder for all expenses of completion up to but not exceeding the penal sum stated above.

The Surety hereby stipulates and agrees that no change, extension of time, alteration or addition to the terms of the Contract or to the work to be performed thereunder or the Specifications accompanying the same shall in any way affect its obligation on this Performance Bond, and it does hereby waive notice of any such change, extension of time, alteration or addition to the terms of the Contract or to the work or to the Specifications.

This Performance Bond shall be governed by and construed in accordance with the laws of the State of Maryland and any reference herein to Principal or Surety in the singular shall include all entities in the plural who or which are signatories under the Principal or Surety heading below.

IN WITNESS WHEREOF, Principal and Surety have set their hands and seals to this Performance Bond. If any individual is a signatory under the Principal heading below, then each such individual has signed below on his or her own behalf, has set forth below the name of the firm, if any, in whose name he or she is doing business, and has set forth below his or her title as a sole proprietor. If any partnership or joint venture is a signatory under the Principal heading below, then all members of each such partnership or joint venture have signed below, each member has set forth below the name of the partnership or joint venture, and each member has set forth below his or her title as a general partner, limited partner, or member of joint venture, whichever is applicable. If any corporation is a signatory under the Principal or Surety heading below, then each such corporation has caused the following: the corporation's name to be set forth below, a duly authorized representative of the corporation to affix below the

corporation's seal and to attach hereto a notarized corporate resolution of power of attorney authorizing such action, and each such duly authorized representative to sign below and set forth below his or her title as a representative of the corporation. If any individual acts as a witness to any signature below, then each such individual has signed below and has set forth below his or her title as a witness. All of the above has been done as of the Date of Bond shown above.

In Presence of: Individual Principal
 Witness: _____ as to _____ (SEAL)

In Presence of: Co-Partnership Principal
 Witness: _____ (SEAL)
 _____ (Name of Co-Partnership)
 By: _____ (SEAL)
 _____ as to _____ (SEAL)
 _____ as to _____ (SEAL)
 _____ as to _____ (SEAL)

Corporate Principal

 (Name of Corporation)
 AFFIX
 Attest: _____ as to _____ CORPORATE
 Corporate Secretary President SEAL

Attest: _____ (SEAL) By: _____ (SEAL)
 Signature Title _____
 Bonding Agent's Name: _____
 Agent's Address _____ (Business Address of Surety)

Approved as to legal form and sufficiency this
 _____ day of _____ 20 _____

 Asst. Attorney General

B. Payment Bond. The required payment bond shall be in the form specified as follows:

PAYMENT BOND

Principal	Business Address of Principal
Surety	Obligee
a corporation of the State of _____	STATE OF MARYLAND
and authorized to do business in the State of Maryland	
Penal Sum of Bond (express in words and figures)	Date of Contract
_____	_____, 20 _____
Description of Contract	Date Bond Executed
Contract Number: _____	_____, 20 _____

KNOW ALL BY THESE PRESENTS, That we, the Principal named above and Surety named above, being authorized to do business in Maryland, and having business address as shown above, are held and firmly bound unto the Obligee named above, for the use and benefit of claimants as hereinafter defined, in the Penal Sum of this Payment Bond stated above, for the payment of which Penal Sum we bind ourselves, our heirs, executors, administrators, personal representatives, successors, and assigns, jointly and severally, firmly by these co-sureties, bind ourselves, our successors and assigns, in such Penal Sum jointly and severally as well as severally only for the purpose of allowing a joint action or actions against any or all of us, and for all other

purposes each co-surety binds itself, jointly and severally with the Principal, for the payment of such sum as appears above its name below, but if no limit of liability is indicated, the limit of such liability shall be the full amount of the Penal Sum.

WHEREAS, Principal has entered into or will enter into a contract with the State, by and through the Administration named above acting for the State of Maryland, which contract is described and dated as shown above, and incorporated herein by reference. The contract and all items incorporated into the contract, together with any and all changes, extensions of time, alterations, modifications, or additions to the contract or to the work to be performed thereunder or to the Plans, Specifications, and Special Provisions, or any of them, or to any other items incorporated into the contract shall hereinafter be referred to as the "Contract".

WHEREAS, it is one of the conditions precedent to the final award of the Contract that these presents be executed.

NOW THEREFORE, the condition of this obligation is such that if the Principal shall promptly make payment to all claimants as hereinafter defined, for all labor and materials furnished, supplied and reasonably required for use in the performance of the Contract, then this obligation shall be null and void; otherwise it shall remain in full force and effect, subject to the following conditions:

1. A claimant is defined to be any and all of those persons supplying services or materials (including lessors of equipment to the extent of the fair market value thereof) to the Principal or its subcontractors and subcontractors in the prosecution of the work provided for in the Contract.

2. The above named Principal and Surety hereby jointly and severally agree with the Obligees that every claimant as herein defined, may sue on this Bond for the use of such claimant and prosecute the suit to final judgment for such sum or sums as may be justly due claimant and have execution thereon. The Obligees shall not be liable for the payment of any costs or expenses of any such suit.

The Surety hereby stipulates and agrees that no change, extension of time, alteration or addition to the terms of the Contract or to the work to be performed thereunder or the Specifications accompanying the same shall in any way affect its obligation on this Payment Bond, and it does hereby waive notice of any such change, extension of time, alteration or addition to the terms of the Contract or to the work or to the Specifications.

This Payment Bond shall be governed by and construed in accordance with the laws of the State of Maryland and any reference herein to Principal or Surety in the singular shall include all entities in the plural who or which are signatories under the Principal or Surety heading below.

IN WITNESS WHEREOF, Principal and Surety have set their hands and seals to this Payment Bond. If any individual is a signatory under the Principal heading below, then each such individual has signed below on his or her own behalf, has set forth below the name of the firm, if any, in whose name he or she is doing business, and has set forth below his or her title as a sole proprietor. If any partnership or joint venture is a signatory under the Principal heading below, then all members of each such partnership or joint venture have signed below, each member has set forth below the name of the partnership or joint venture, and each member has set forth below his or her title as a general partner, limited partner, or member of joint venture, whichever is applicable. If any corporation is a signatory under the Principal or Surety heading below, then each such corporation has caused the following: the corporation's name to be set forth below, a duly authorized representative of the corporation to affix below the corporation's seal and to attach hereto a notarized corporate resolution of power of attorney authorizing such action, and each such duly authorized representative to sign below and set forth below his or her title as a representative of the corporation. If any individual acts as a witness to any signature below, then each such individual has signed below and has set forth below his or her title as a witness. All of the above has been done as of the Date of Bond shown above.

In Presence of:

Witness: _____ as to

Individual Principal

_____(SEAL)

In Presence of:

Witness: _____ as to
_____ as to
_____ as to

Co-Partnership Principal

_____(SEAL)

(Name of Co-Partnership)

By: _____(SEAL)

_____(SEAL)

_____(SEAL)

Attest:

Corporate Secretary

Attest:

(SEAL)

Signature

Bonding Agent's Name: _____

Agent's Address _____

Corporate Principal

(Name of Corporation)

AFFIX

By: _____ CORPORATE
President SEAL

(Corporate Surety)

By: _____ (SEAL)

Title _____

(Business Address of Surety)

Approved as to legal form and sufficiency this
_____ day of _____ 20 _____

Asst. Attorney General

.28 Performance and Payment Bonds — Multiyear Annual and Renewable.

This regulation is added as a separate pdf form within this chapter.

.28 Performance and Payment Bonds—Multiyear Annual and Renewable.

Optional forms for multiyear contracts exceeding \$100,000 with annual and renewable surety bonds:

A. Performance Bond. The required performance bond shall be in the form specified as follows:

ANNUAL PERFORMANCE BOND – RENEWABLE FOR MULTIYEAR AWARDS

Principal	Business Address of Principal
Surety	Obligee
a corporation of the State of _____	STATE OF MARYLAND
and authorized to do business in the State of Maryland	
	Date Bond Executed
Penal Sum of Bond (express in words and figures)	_____, 20____
_____	Initial Term Fiscal Year Ending
	June 30, 20____

KNOW ALL BY THESE PRESENTS, That we, the Principal named above and Surety named above, are held and firmly bound unto the Obligee named above in the Penal Sum of this Performance Bond stated above, for the payment of which Penal Sum we bind ourselves, our heirs, executors, administrators, personal representatives, successors, and assigns, jointly and severally, firmly by these presents. However, where Surety is composed of corporations acting as co-sureties, we the co-sureties, bind ourselves, our successors and assigns, in such Penal Sum jointly and severally as well as severally only for the purpose of allowing a joint action or actions against any or all of us, and for all other purposes each co-surety binds itself, jointly and severally with the Principal, for the payment of such sum as appears above its name below, but if no limit of liability is indicated, the limit of such liability shall be the full amount of the Penal Sum.

WHEREAS, Principal has entered into or will enter into a multiyear contract with the State, by and through the Administration named above acting for the State of Maryland, which contract is described above, and incorporated herein by reference. The contract and all items incorporated into the contract, together with any and all changes, extensions of time, alterations, modifications, or additions to the contract or to the work to be performed thereunder or to the Plans, Specifications, and Special Provisions, or any of them, or to any other items incorporated into the contract shall hereinafter be referred to as the "Contract".

The term of this Bond is for the period beginning on the date the bond is executed and ending on the indicated Initial Term Fiscal Year Ending Date (the "Initial Term"). If requested by the Principal, the Initial Term may be extended, solely at the option of the Surety, for additional one (1) year periods (each a "Renewal Term"), ending on the subsequent Fiscal Year ending date. This Bond shall expire at the end of the Initial Term or, if extended, at the end of the final Renewal Term. Provided that at any time should the surety elect not to extend the bond for a Renewal Term, it must so inform the Obligee in writing prior to ninety (90) days before the expiry of the existing Initial Term or final Renewal Term. If the surety does not so inform the Obligee of its intention not to extend the bond as stated herein, the bond will automatically be deemed extended for an additional Renewal Term.

WHEREAS, it is one of the conditions precedent to the final award of the Contract that these presents be executed.

NOW, THEREFORE, during the initial term of said Contract, any renewal term, and during any extensions thereto that may be granted by the Administration, and during the guarantee and warranty period, if any, required under the Contract, unless otherwise stated therein, this Performance Bond shall remain in full force and effect unless and until the following terms and conditions are met:

1. Principal shall well and truly perform the Contract; and
2. Principal and Surety shall comply with the terms and conditions in this Performance Bond.

Whenever Principal shall be declared by the Administration to be in default under the Contract, the Surety may, within 15 days after notice of default from the Administration, notify the Administration of its election to either promptly proceed to remedy the default or promptly proceed to complete the contract in accordance with and subject to its terms and conditions. In the event the Surety does not elect to exercise either of the above stated options, then the Administration thereupon shall have the remaining contract work completed, Surety to remain liable hereunder for all expenses of completion up to but not exceeding the penal sum stated above.

The Surety hereby stipulates and agrees that no change, extension of time, alteration or addition to the terms of the Contract or to the work to be performed thereunder or the Specifications accompanying the same shall in any way affect its obligation on this Performance Bond, and it does hereby waive notice of any such change, extension of time, alteration or addition to the terms of the Contract or to the work or to the Specifications.

This Performance Bond shall be governed by and construed in accordance with the laws of the State of Maryland and any reference herein to Principal or Surety in the singular shall include all entities in the plural who or which are signatories under the Principal or Surety heading below.

IN WITNESS WHEREOF, Principal and Surety have set their hands and seals to this Performance Bond. If any individual is a signatory under the Principal heading below, then each such individual has signed below on his or her own behalf, has set forth below the name of the firm, if any, in whose name he or she is doing business, and has set forth below his or her title as a sole proprietor. If any partnership or joint venture is a signatory under the Principal heading below, then all members of each such partnership or joint venture have signed below, each member has set forth below the name of the partnership or joint venture, and each member has set forth below his or her title as a general partner, limited partner, or member of joint venture, whichever is applicable. If any corporation is a signatory under the Principal or Surety heading below, then each such corporation has caused the following: the corporation's name to be set forth below, a duly authorized representative of the corporation to affix below the corporation's seal and to attach hereto a notarized corporate resolution of power of attorney authorizing such action, and each such duly authorized representative to sign below and set forth below his or her title as a representative of the corporation. If any individual acts as a witness to any signature below, then each such individual has signed below and has set forth below his or her title as a witness. All of the above has been done as of the Date of Bond shown above.

In Presence of:

Witness:

_____ as to

Individual Principal

_____ (SEAL)

In Presence of:

Witness:

Co-Partnership Principal

_____ (SEAL)

(Name of Co-Partnership)

_____ as to

By: _____ (SEAL)

_____ as to

_____ (SEAL)

_____ as to

_____ (SEAL)

Corporate Principal

Attest:

_____ (Name of Corporation)

AFFIX

_____ as to

By: _____ CORPORATE

Corporate Secretary

President

SEAL

Attest:

(SEAL)

_____ (Corporate Surety)

By: _____ (SEAL)

Signature

Title _____

Bonding Agent's Name: _____

_____ (Business Address of Surety)

Agent's Address _____

Approved as to legal form and sufficiency this

_____ day of _____ 20 _____

_____ Asst. Attorney General

B. Payment Bond. The required payment bond shall be in the form specified as follows:

ANNUAL PAYMENT BOND – RENEWABLE FOR MULTIYEAR AWARDS

Principal	Business Address of Principal
Surety	Obligee
a corporation of the State of _____	STATE OF MARYLAND
and authorized to do business in the State of Maryland	
Penal Sum of Bond (express in words and figures)	Date Bond Executed
_____	_____, 20____
	Initial Term Fiscal Year Ending
	June 30, 20____

KNOW ALL BY THESE PRESENTS, That we, the Principal named above and Surety named above, being authorized to do business in Maryland, and having business address as shown above, are held and firmly bound unto the Obligee named above, for the use and benefit of claimants as hereinafter defined, in the Penal Sum of this Payment Bond stated above, for the payment of which Penal Sum we bind ourselves, our heirs, executors, administrators, personal representatives, successors, and assigns, jointly and severally, firmly by these co-sureties, bind ourselves, our successors and assigns, in such Penal Sum jointly and severally as well as severally only for the purpose of allowing a joint action or actions against any or all of us, and for all other purposes each co-surety binds itself, jointly and severally with the Principal, for the payment of such sum as appears above its name below, but if no limit of liability is indicated, the limit of such liability shall be the full amount of the Penal Sum.

WHEREAS, Principal has entered into or will enter into a multiyear contract with the State, by and through the Administration named above acting for the State of Maryland, which contract is described above, and incorporated herein by reference. The contract and all items incorporated into the contract, together with any and all changes, extensions of time, alterations, modifications, or additions to the contract or to the work to be performed thereunder or to the Plans, Specifications, and Special Provisions, or any of them, or to any other items incorporated into the contract shall hereinafter be referred to as the "Contract".

The term of this Bond is for the period beginning on the date the bond is executed and ending on the indicated Initial Term Fiscal Year Ending Date (the "Initial Term"). If requested by the Principal, the Initial Term may be extended, solely at the option of the Surety, for additional one (1) year periods (each a "Renewal Term"), ending on the subsequent Fiscal Year ending date. This Bond shall expire at the end of the Initial Term or, if extended, at the end of the final Renewal Term. Provided that at any time should the surety elect not to extend the bond for a Renewal Term, it must so inform the Obligee in writing prior to ninety (90) days before the expiry of the existing Initial Term or final Renewal Term. If the surety does not so inform the Obligee of its intention not to extend the bond as stated herein, the bond will automatically be deemed extended for an additional Renewal Term.

WHEREAS, it is one of the conditions precedent to the final award of the Contract that these presents be executed.

NOW THEREFORE, the condition of this obligation is such that if the Principal shall promptly make payment to all claimants as hereinafter defined, for all labor and materials furnished, supplied and reasonably required for use in the performance of the Contract, then this obligation shall be null and void; otherwise it shall remain in full force and effect, subject to the following conditions:

1. A claimant is defined to be any and all of those persons supplying services or materials (including lessors of equipment to the extent of the fair market value thereof) to the Principal or its subcontractors and subcontractors in the prosecution of the work provided for in the Contract.

2. The above named Principal and Surety hereby jointly and severally agree with the Obligee that every claimant as herein defined, may sue on this Bond for the use of such claimant and prosecute the suit to final judgment for such sum or sums as may be justly due claimant and have execution thereon. The Obligee shall not be liable for the payment of any costs or expenses of any such suit.

The Surety hereby stipulates and agrees that no change, extension of time, alteration or addition to the terms of a Contract or to the work to be performed thereunder or the Specifications accompanying the same shall in any way affect its obligation on this Payment Bond, and it does hereby waive notice of any such change, extension of time, alteration or addition to the terms of a Contract or to the work or to the Specifications.

This Payment Bond shall be governed by and construed in accordance with the laws of the State of Maryland and any reference herein to Principal or Surety in the singular shall include all entities in the plural who or which are signatories under the Principal or Surety heading below.

IN WITNESS WHEREOF, Principal and Surety have set their hands and seals to this Payment Bond. If any individual is a signatory under the Principal heading below, then each such individual has signed below on his or her own behalf, has set forth below the name of the firm, if any, in whose name he or she is doing business, and has set forth below his or her title as a sole proprietor. If any partnership or joint venture is a signatory under the Principal heading below, then all members of each such partnership or joint venture have signed below, each member has set forth below the name of the partnership or joint venture, and

each member has set forth below his or her title as a general partner, limited partner, or member of joint venture, whichever is applicable. If any corporation is a signatory under the Principal or Surety heading below, then each such corporation has caused the following: the corporation's name to be set forth below, a duly authorized representative of the corporation to affix below the corporation's seal and to attach hereto a notarized corporate resolution of power of attorney authorizing such action, and each such duly authorized representative to sign below and set forth below his or her title as a representative of the corporation. If any individual acts as a witness to any signature below, then each such individual has signed below and has set forth below his or her title as a witness. All of the above has been done as of the Date of Bond shown above.

In Presence of: _____ Individual Principal
 Witness: _____ as to _____ (SEAL)

In Presence of: _____ Co-Partnership Principal
 Witness: _____ (SEAL)
 _____ (Name of Co-Partnership)
 By: _____ (SEAL)
 _____ as to _____ (SEAL)
 _____ as to _____ (SEAL)
 _____ as to _____ (SEAL)

Corporate Principal

 (Name of Corporation)
 AFFIX
 By: _____ CORPORATE
 President SEAL

Attest: _____ (SEAL)
 _____ (Corporate Surety)
 By: _____ (SEAL)
 Title _____

Signature
 Bonding Agent's Name: _____

 (Business Address of Surety)

Agent's Address _____

Approved as to legal form and sufficiency this
 _____ day of _____ 20 _____

 Asst. Attorney General

STATE PROCUREMENT REGULATIONS

21.07.01.28

Administrative History

Effective date: July 1, 1981 (8:13 Md. R. II-5)

Regulation .09A amended effective May 6, 1985 (12:9 Md. R. 816)

Chapter revised effective January 9, 1989 (15:27 Md. R. 3138)

Regulation .03 amended effective August 2, 1993 (20:15 Md. R. 1221)

Regulation .05 amended effective October 2, 2000 (27:19 Md. R. 1730), July 9, 2001 (28:13 Md. R. 1216)

Regulation .08 amended effective December 25, 2000 (27:25 Md. R. 2284); January 2, 2017 (43:26 Md. R. 1449)

Regulation .11A amended effective November 22, 1993 (20:23 Md. R. 1086)

Regulation .12A amended effective November 22, 1993 (20:23 Md. R. 1086)

Regulation .14 amended effective May 13, 2013 (40:9 Md. R. 789); July 15, 2019 (46:14 Md. R. 623)

Regulation .18 amended effective January 2, 2017 (43:26 Md. R. 1449)

Regulation .19 amended effective March 11, 2019 (46:5 Md. R. 310)

Regulation .20 amended effective January 26, 1998 (25:2 Md. R. 79); December 25, 2000 (27:25 Md. R. 2284); January 2, 2017 (43:26 Md. R. 1449)

Regulation .25 amended effective October 1, 1990 (17:19 Md. R. 2322); August 2, 1993 (20:15 Md. R. 1221); August 8, 2011 (38:16 Md. R. 946); May 13, 2013 (40:9 Md. R. 789)

Regulation .25C amended effective March 11, 2019 (46:5 Md. R. 310)

Regulation .25D amended effective January 2, 2017 (43:26 Md. R. 1449)

Regulation .26 adopted as an emergency provision effective August 8, 1997 (24:18 Md. R. 1294); emergency status rescinded effective October 16, 1997 (24:23 Md. R. 1608)

Regulation .26 adopted effective March 12, 2007 (34:5 Md. R. 562)

Regulation .26A amended effective January 2, 2017 (43:26 Md. R. 1449)

Regulation .26B amended effective March 5, 2012 (39:4 Md. R. 338)

Regulation .27 adopted effective July 15, 2019 (46:14 Md. R. 623)

Regulation .28 adopted effective July 15, 2019 (46:14 Md. R. 623)

Maryland State Admin Fee: Estimated at 1%, but any fee will be determined at such time Maryland may elect to negotiate any Participating Addendum.

**STATE OF TENNESSEE PARTICIPATING ADDENDUM
TO NASPO RFP AZ-BPM003137
MAILING EQUIPMENT, SUPPLIES, AND MAINTENANCE**

- A. SCOPE:** This State of Tennessee Participating Addendum (hereinafter "Contract") by and between the State of Tennessee ("hereinafter "State") and Company(ies) (hereinafter "Contractor") is for the provision of Mailroom Equipment, Supplies and Maintenance.
- A.1. The Contractor shall provide all goods or services and deliverables as required, described, and detailed below and shall meet all service and delivery timelines as specified by this Contract.

B. TERM OF CONTRACT:

The term of this Participating Addendum will be effective upon the final execution date by the Participating State and co-terminus with the Master Agreement term unless otherwise cancelled or terminated as set forth in this Participating Addendum by the Participating State. Lead State amendments to extend the term date shall be incorporated into this Participating Addendum upon approval by the Participating State.

Special note regarding Term of Contract. The NASPO ValuePoint term is a one (1) year contract term ending DATE, with four (4) additional one-year options to renew. No new leases will be entered beyond the end of year five (5) (DATE) from the resulting contract. The remaining five (5) years of the Edison statewide contract will allow agencies to complete the existing lease terms.

C. PAYMENT TERMS AND CONDITIONS:

- C.1. Estimated Liability. The total purchases of any goods or services under the Contract are not known. The State estimates the purchases during the Term shall be four million seven hundred thirty-five thousand five hundred dollars (\$4,735,500.00) ("Estimated Liability"). This Contract does not grant the Contractor any exclusive rights. The State does not guarantee that it will buy any minimum quantity of goods or services under this Contract. Subject to the terms and conditions of this Contract, the Contractor will only be paid for goods or services provided under this Contract after a purchase order is issued to Contractor by the State or as otherwise specified by this Contract.
- C.2. Price Changes. Prices listed in awarded published catalog, price lists or price schedule shall remain firm for three hundred sixty-five (365) days ("Firm Price Period").
- a. Price Decreases. After the Firm Price Period, prices shall be equitably adjusted to reflect a decrease in Contractor's costs.
- b. Price Increases. After the Firm Price Period, Contractor may request price increases. The request shall: include copies of the new price lists or catalog that reflect a change in the Contractor's cost; not constitute an increase in profit; and apply to all of the Contractor's customers.
- c. Approval of Price Changes. The State may at its sole option: (1) grant the Contractor's request; (2) cancel the Contract and award it to the next apparent best evaluated Respondent; (3) cancel the Contract and reissue the solicitation; or (4) deny the Contractor's request. If approved, any price changes of less than seven percent (7%) will become effective upon the State's approval in writing. Price changes exceeding seven percent (7%) shall require a Contract amendment. The Contractor shall honor all purchase orders dated prior to the approved price change. Upon request from the State, the Contractor shall furnish the approved catalog, price schedule or price list as applicable to the State at no charge.
- C.3. Payment Methodology. The Contractor shall be compensated based on the payment rates for goods or services contained in Contract Appendix # and as authorized by the State in a total

amount as set forth in Section C.1. The Contractor's compensation shall be contingent upon the satisfactory provision of goods or services as set forth in Section A.

- C.4. Travel Compensation. The Contractor shall not be compensated or reimbursed for travel time, travel expenses, meals, or lodging.
- C.5. Invoice Requirements. The Contractor shall invoice the State only for goods delivered and accepted by the State or services satisfactorily provided at the amounts stipulated in Section C.3., above. Contractor shall submit invoices and necessary supporting documentation, no more frequently than once a month, and no later than thirty (30) days after goods or services have been provided to the following address:

State Agency Billing Address

- a. Each invoice, on Contractor's letterhead, shall clearly and accurately detail all of the following information (calculations must be extended and totaled correctly):
- (1) Invoice number (assigned by the Contractor);
 - (2) Invoice date;
 - (3) Contract number (assigned by the State);
 - (4) Customer account name: State Agency & Division Name;
 - (5) Customer account number (assigned by the Contractor to the above-referenced Customer);
 - (6) Contractor name;
 - (7) Contractor Tennessee Edison registration ID number;
 - (8) Contractor contact for invoice questions (name, phone, or email);
 - (9) Contractor remittance address;
 - (10) Description of delivered goods or services provided and invoiced, including identifying information as applicable;
 - (11) Number of delivered or completed units, increments, hours, or days as applicable, of each good or service invoiced;
 - (12) Applicable payment methodology (as stipulated in Section C.3.) of each good or service invoiced;
 - (13) Amount due for each compensable unit of good or service; and
 - (14) Total amount due for the invoice period.
- b. Contractor's invoices shall:
- (1) Only include charges for goods delivered or services provided as described in Section A and in accordance with payment terms and conditions set forth in Section C;
 - (2) Only be submitted for goods delivered or services completed and shall not include any charge for future goods to be delivered or services to be performed;
 - (3) Not include Contractor's taxes, which includes without limitation Contractor's sales and use tax, excise taxes, franchise taxes, real or personal property taxes, or income taxes; and
 - (4) Include shipping or delivery charges only as authorized in this Contract.
- c. The timeframe for payment (or any discounts) begins only when the State is in receipt of an invoice that meets the minimum requirements of this Section C.5.
- C.6. Payment of Invoice. A payment by the State shall not prejudice the State's right to object to or question any payment, invoice, or other matter. A payment by the State shall not be construed as acceptance of goods delivered, any part of the services provided, or as approval of any amount invoiced.
- C.7. Invoice Reductions. The Contractor's invoice shall be subject to reduction for amounts included in any invoice or payment that is determined by the State, on the basis of audits conducted in

accordance with the terms of this Contract, to not constitute proper compensation for goods delivered or services provided.

- C.8. Deductions. The State reserves the right to deduct from amounts, which are or shall become due and payable to the Contractor under this or any contract between the Contractor and the State of Tennessee, any amounts that are or shall become due and payable to the State of Tennessee by the Contractor.
- C.9. Prerequisite Documentation. The Contractor shall not invoice the State under this Contract until the State has received the following, properly completed documentation.
 - a. The Contractor shall complete, sign, and present to the State the "Authorization Agreement for Automatic Deposit Form" provided by the State. By doing so, the Contractor acknowledges and agrees that, once this form is received by the State, payments to the Contractor, under this or any other contract the Contractor has with the State of Tennessee, may be made by ACH; and
 - b. The Contractor shall complete, sign, and return to the State the State-provided W-9 form. The taxpayer identification number on the W-9 form must be the same as the Contractor's Federal Employer Identification Number or Social Security Number referenced in the Contractor's Edison registration information.

D. MANDATORY TERMS AND CONDITIONS:

- D.1. Required Approvals. The State is not bound by this Contract until it is duly approved by the Parties and all appropriate State officials in accordance with applicable Tennessee laws and regulations. Depending upon the specifics of this Contract, this may include approvals by the Commissioner of Finance and Administration, the Commissioner of Human Resources, the Comptroller of the Treasury, and the Chief Procurement Officer. Approvals shall be evidenced by a signature or electronic approval.
- D.2. Communications and Contacts. All instructions, notices, consents, demands, or other communications required or contemplated by this Contract shall be in writing and shall be made by certified, first class mail, return receipt requested and postage prepaid, by overnight courier service with an asset tracking system, or by email or facsimile transmission with recipient confirmation. All communications, regardless of method of transmission, shall be addressed to the respective Party at the appropriate mailing address, facsimile number, or email address as stated below or any other address provided in writing by a Party.

The State:

Mr. Erik Busby, Category Specialist
Central Procurement Office
Tennessee Tower, 3rd Floor
312 Rosa L. Parks Avenue
Nashville, TN 37243
Erik.Busby@tn.gov
Telephone # 615-253-8900
FAX # 615-741-0684

The Contractor:

Contractor Contact Name & Title
Contractor Name
Address
Email Address
Telephone # Number
FAX # Number

All instructions, notices, consents, demands, or other communications shall be considered effective upon receipt or recipient confirmation as may be required.

- D.3. Modification and Amendment. This Contract may be modified only by a written amendment signed by all Parties and approved by all applicable State officials.
- D.4. Subject to Funds Availability. The Contract is subject to the appropriation and availability of State or federal funds. In the event that the funds are not appropriated or are otherwise unavailable, the State reserves the right to terminate this Contract upon written notice to the Contractor. The State's exercise of its right to terminate this Contract shall not constitute a breach of Contract by the State. Upon receipt of the written notice, the Contractor shall cease all work associated with the Contract. If the State terminates this Contract due to lack of funds availability, the Contractor shall be entitled to compensation for all conforming goods requested and accepted by the State and for all satisfactory and authorized services completed as of the termination date. Should the State exercise its right to terminate this Contract due to unavailability of funds, the Contractor shall have no right to recover from the State any actual, general, special, incidental, consequential, or any other damages of any description or amount.
- D.5. Termination for Convenience. The State may terminate this Contract for convenience without cause and for any reason. The State shall give the Contractor at least sixty (60) days written notice before the termination date. The Contractor shall be entitled to compensation for all conforming goods delivered and accepted by the State or for satisfactory, authorized services completed as of the termination date. In no event shall the State be liable to the Contractor for compensation for any goods neither requested nor accepted by the State or for any services neither requested by the State nor satisfactorily performed by the Contractor. In no event shall the State's exercise of its right to terminate this Contract for convenience relieve the Contractor of any liability to the State for any damages or claims arising under this Contract.
- D.6. Termination for Cause. If the Contractor fails to properly perform its obligations under this Contract in a timely or proper manner, or if the Contractor materially violates any terms of this Contract ("Breach Condition"), the State shall have the right to immediately terminate the Contract and withhold payments in excess of compensation for completed services or provided goods. Notwithstanding the above, the Contractor shall not be relieved of liability to the State for damages sustained by virtue of any Breach Condition and the State may seek other remedies allowed at law or in equity for breach of this Contract.
- D.7. Assignment and Subcontracting. The Contractor shall not assign this Contract or enter into a subcontract for any of the goods or services provided under this Contract without the prior written approval of the State. Notwithstanding any use of the approved subcontractors, the Contractor shall be the prime contractor and responsible for compliance with all terms and conditions of this Contract. The State reserves the right to request additional information or impose additional terms and conditions before approving an assignment of this Contract in whole or in part or the use of subcontractors in fulfilling the Contractor's obligations under this Contract.
- D.8. Conflicts of Interest. The Contractor warrants that no part of the Contractor's compensation shall be paid directly or indirectly to an employee or official of the State of Tennessee as wages, compensation, or gifts in exchange for acting as an officer, agent, employee, subcontractor, or consultant to the Contractor in connection with any work contemplated or performed under this Contract.
- The Contractor acknowledges, understands, and agrees that this Contract shall be null and void if the Contractor is, or within the past six (6) months has been, an employee of the State of Tennessee or if the Contractor is an entity in which a controlling interest is held by an individual who is, or within the past six (6) months has been, an employee of the State of Tennessee.
- D.9. Nondiscrimination. The Contractor hereby agrees, warrants, and assures that no person shall be excluded from participation in, be denied benefits of, or be otherwise subjected to discrimination in the performance of this Contract or in the employment practices of the Contractor on the grounds of handicap or disability, age, race, creed, color, religion, sex, national origin, or any

other classification protected by federal or state law. The Contractor shall, upon request, show proof of nondiscrimination and shall post in conspicuous places, available to all employees and applicants, notices of nondiscrimination.

D.10. Equal Opportunity. The Contractor agrees as follows:

- a. The Contractor will not discriminate against any employee or applicant for employment because of race, color, religion, sex, sexual orientation, gender identity, or national origin. The Contractor will take affirmative action to ensure that applicants are employed, and that employees are treated during employment, without regard to their race, color, religion, sex, sexual orientation, gender identity, or national origin. Such action shall include, but not be limited to the following:
 - (1) Employment, upgrading, demotion, or transfer, recruitment or recruitment advertising;
 - (2) Layoff or termination;
 - (3) Rates of pay or other forms of compensation; and
 - (4) Selection for training, including apprenticeship.

The Contractor agrees to post in conspicuous places, available to employees and applicants for employment, notices to be provided by the contracting officer setting forth the provisions of this nondiscrimination clause.

- b. The Contractor will, in all solicitations or advertisements for employees placed by or on behalf of the Contractor, state that all qualified applicants will receive considerations for employment without regard to race, color, religion, sex, sexual orientation, gender identity, or national origin.
- c. If the State approves any subcontract, the subcontract shall include paragraphs (a) and (b) above.
- d. In addition, to the extent applicable the Contractor agrees to comply with 41 C.F. R. § 60-1.4, as that section is amended from time to time during the term.

D.11. Prohibition of Illegal Immigrants. The requirements of Tenn. Code Ann. § 12-3-309 addressing the use of illegal immigrants in the performance of any contract to supply goods or services to the state of Tennessee, shall be a material provision of this Contract, a breach of which shall be grounds for monetary and other penalties, up to and including termination of this Contract.

- a. The Contractor agrees that the Contractor shall not knowingly utilize the services of an illegal immigrant in the performance of this Contract and shall not knowingly utilize the services of any subcontractor who will utilize the services of an illegal immigrant in the performance of this Contract. The Contractor shall reaffirm this attestation, in writing, by submitting to the State a completed and signed copy of the document at Attachment 1, semi-annually during the Term. If the Contractor is a party to more than one contract with the State, the Contractor may submit one attestation that applies to all contracts with the State. All Contractor attestations shall be maintained by the Contractor and made available to State officials upon request.
- b. Prior to the use of any subcontractor in the performance of this Contract, and semi-annually thereafter, during the Term, the Contractor shall obtain and retain a current, written attestation that the subcontractor shall not knowingly utilize the services of an illegal immigrant to perform work under this Contract and shall not knowingly utilize the services of any subcontractor who will utilize the services of an illegal immigrant to perform work under this Contract. Attestations obtained from subcontractors shall be maintained by the Contractor and made available to State officials upon request.
- c. The Contractor shall maintain records for all personnel used in the performance of this Contract. Contractor's records shall be subject to review and random inspection at any reasonable time upon reasonable notice by the State.

- d. The Contractor understands and agrees that failure to comply with this section will be subject to the sanctions of Tenn. Code Ann. § 12-3-309 for acts or omissions occurring after its effective date.
 - e. For purposes of this Contract, "illegal immigrant" shall be defined as any person who is not: (i) a United States citizen; (ii) a Lawful Permanent Resident; (iii) a person whose physical presence in the United States is authorized; (iv) allowed by the federal Department of Homeland Security and who, under federal immigration laws or regulations, is authorized to be employed in the U.S.; or (v) is otherwise authorized to provide services under the Contract.
- D.12. Records. The Contractor shall maintain documentation for all charges under this Contract. The books, records, and documents of the Contractor, for work performed or money received under this Contract, shall be maintained for a period of five (5) full years from the date of the final payment and shall be subject to audit at any reasonable time and upon reasonable notice by the State, the Comptroller of the Treasury, or their duly appointed representatives. The financial statements shall be prepared in accordance with generally accepted accounting principles.
- D.13. Monitoring. The Contractor's activities conducted and records maintained pursuant to this Contract shall be subject to monitoring and evaluation by the State, the Comptroller of the Treasury, or their duly appointed representatives.
- D.14. Progress Reports. The Contractor shall submit brief, periodic, progress reports to the State as requested.
- D.15. Strict Performance. Failure by any Party to this Contract to require, in any one or more cases, the strict performance of any of the terms, covenants, conditions, or provisions of this Contract shall not be construed as a waiver or relinquishment of any term, covenant, condition, or provision. No term or condition of this Contract shall be held to be waived, modified, or deleted except by a written amendment signed by the Parties.
- D.16. Independent Contractor. The Parties shall not act as employees, partners, joint venturers, or associates of one another. The Parties are independent contracting entities. Nothing in this Contract shall be construed to create an employer/employee relationship or to allow either Party to exercise control or direction over the manner or method by which the other transacts its business affairs or provides its usual services. The employees or agents of one Party are not employees or agents of the other Party.
- D.17. Patient Protection and Affordable Care Act. The Contractor agrees that it will be responsible for compliance with the Patient Protection and Affordable Care Act ("PPACA") with respect to itself and its employees, including any obligation to report health insurance coverage, provide health insurance coverage, or pay any financial assessment, tax, or penalty for not providing health insurance. The Contractor shall indemnify the State and hold it harmless from any costs to the State arising from Contractor's failure to fulfill its PPACA responsibilities for itself or its employees.
- D.18. Limitation of State's Liability. The State shall have no liability except as specifically provided in this Contract. In no event will the State be liable to the Contractor or any other party for any lost revenues, lost profits, loss of business, decrease in the value of any securities or cash position, time, goodwill, or any indirect, special, incidental, punitive, exemplary or consequential damages of any nature, whether based on warranty, contract, statute, regulation, tort (including but not limited to negligence), or any other legal theory that may arise under this Contract or otherwise. Notwithstanding anything else herein, the State's total liability under this Contract (including without limitation any exhibits, schedules, amendments or other attachments to the Contract) or otherwise shall under no circumstances exceed the Estimated Liability. This limitation of liability is cumulative and not per incident.

- D.19. Limitation of Contractor's Liability. In accordance with Tenn. Code Ann. § 12-3-701, the Contractor's liability for all claims arising under this Contract shall be limited to an amount equal to two (2) times the Estimated Liability amount detailed in Section C.1. and as may be amended, PROVIDED THAT in no event shall this Section limit the liability of the Contractor for: (i) intellectual property or any Contractor indemnity obligations for infringement for third-party intellectual property rights; (ii) any claims covered by any specific provision in the Contract providing for liquidated damages; or (iii) any claims for intentional torts, criminal acts, fraudulent conduct, or acts or omissions that result in personal injuries or death.
- D.20. Hold Harmless. The Contractor agrees to indemnify and hold harmless the State of Tennessee as well as its officers, agents, and employees from and against any and all claims, liabilities, losses, and causes of action which may arise, accrue, or result to any person, firm, corporation, or other entity which may be injured or damaged as a result of acts, omissions, or negligence on the part of the Contractor, its employees, or any person acting for or on its or their behalf relating to this Contract. The Contractor further agrees it shall be liable for the reasonable cost of attorneys' fees, court costs, expert witness fees, and other litigation expenses for the State to enforce the terms of this Contract.

In the event of any suit or claim, the Parties shall give each other immediate notice and provide all necessary assistance to respond. The failure of the State to give notice shall only relieve the Contractor of its obligations under this Section to the extent that the Contractor can demonstrate actual prejudice arising from the failure to give notice. This Section shall not grant the Contractor, through its attorneys, the right to represent the State in any legal matter, as the right to represent the State is governed by Tenn. Code Ann. § 8-6-106.

- D.21. HIPAA Compliance. The State and Contractor shall comply with obligations under the Health Insurance Portability and Accountability Act of 1996 ("HIPAA"), Health Information Technology for Economic and Clinical Health ("HITECH") Act and any other relevant laws and regulations regarding privacy (collectively the "Privacy Rules"). The obligations set forth in this Section shall survive the termination of this Contract.
- a. Contractor warrants to the State that it is familiar with the requirements of the Privacy Rules, and will comply with all applicable requirements in the course of this Contract.
 - b. Contractor warrants that it will cooperate with the State, including cooperation and coordination with State privacy officials and other compliance officers required by the Privacy Rules, in the course of performance of the Contract so that both parties will be in compliance with the Privacy Rules.
 - c. The State and the Contractor will sign documents, including but not limited to business associate agreements, as required by the Privacy Rules and that are reasonably necessary to keep the State and Contractor in compliance with the Privacy Rules. This provision shall not apply if information received or delivered by the parties under this Contract is NOT "protected health information" as defined by the Privacy Rules, or if the Privacy Rules permit the parties to receive or deliver the information without entering into a business associate agreement or signing another document.
 - d. The Contractor will indemnify the State and hold it harmless for any violation by the Contractor or its subcontractors of the Privacy Rules. This includes the costs of responding to a breach of protected health information, the costs of responding to a government enforcement action related to the breach, and any fines, penalties, or damages paid by the State because of the violation.

- D.22. Tennessee Consolidated Retirement System. Subject to statutory exceptions contained in Tenn. Code Ann. §§ 8-36-801, *et seq.*, the law governing the Tennessee Consolidated Retirement System ("TCRS"), provides that if a retired member of TCRS, or of any superseded system administered by TCRS, or of any local retirement fund established under Tenn. Code Ann. §§ 8-35-101, *et seq.*, accepts State employment, the member's retirement allowance is suspended during the period of the employment. Accordingly and notwithstanding any provision of this

Contract to the contrary, the Contractor agrees that if it is later determined that the true nature of the working relationship between the Contractor and the State under this Contract is that of "employee/employer" and not that of an independent contractor, the Contractor, if a retired member of TCRS, may be required to repay to TCRS the amount of retirement benefits the Contractor received from TCRS during the Term.

- D.23. Tennessee Department of Revenue Registration. The Contractor shall comply with all applicable registration requirements contained in Tenn. Code Ann. §§ 67-6-601 – 608. Compliance with applicable registration requirements is a material requirement of this Contract.
- D.24. Debarment and Suspension. The Contractor certifies, to the best of its knowledge and belief, that it, its current and future principals, its current and future subcontractors and their principals:
- a. are not presently debarred, suspended, proposed for debarment, declared ineligible, or voluntarily excluded from covered transactions by any federal or state department or agency;
 - b. have not within a three (3) year period preceding this Contract been convicted of, or had a civil judgment rendered against them from commission of fraud, or a criminal offense in connection with obtaining, attempting to obtain, or performing a public (federal, state, or local) transaction or grant under a public transaction; violation of federal or state antitrust statutes or commission of embezzlement, theft, forgery, bribery, falsification, or destruction of records, making false statements, or receiving stolen property;
 - c. are not presently indicted or otherwise criminally or civilly charged by a government entity (federal, state, or local) with commission of any of the offenses detailed in section b. of this certification; and
 - d. have not within a three (3) year period preceding this Contract had one or more public transactions (federal, state, or local) terminated for cause or default.

The Contractor shall provide immediate written notice to the State if at any time it learns that there was an earlier failure to disclose information or that due to changed circumstances, its principals or the principals of its subcontractors are excluded, disqualified, or presently fall under any of the prohibitions of sections a-d.

- D.25. Force Majeure. "Force Majeure Event" means fire, flood, earthquake, elements of nature or acts of God, wars, riots, civil disorders, rebellions or revolutions, acts of terrorism or any other similar cause beyond the reasonable control of the Party except to the extent that the non-performing Party is at fault in failing to prevent or causing the default or delay, and provided that the default or delay cannot reasonably be circumvented by the non-performing Party through the use of alternate sources, workaround plans or other means. A strike, lockout or labor dispute shall not excuse either Party from its obligations under this Contract. Except as set forth in this Section, any failure or delay by a Party in the performance of its obligations under this Contract arising from a Force Majeure Event is not a default under this Contract or grounds for termination. The non-performing Party will be excused from performing those obligations directly affected by the Force Majeure Event, and only for as long as the Force Majeure Event continues, provided that the Party continues to use diligent, good faith efforts to resume performance without delay. The occurrence of a Force Majeure Event affecting Contractor's representatives, suppliers, subcontractors, customers or business apart from this Contract is not a Force Majeure Event under this Contract. Contractor will promptly notify the State of any delay caused by a Force Majeure Event (to be confirmed in a written notice to the State within one (1) day of the inception of the delay) that a Force Majeure Event has occurred, and will describe in reasonable detail the nature of the Force Majeure Event. If any Force Majeure Event results in a delay in Contractor's performance longer than forty-eight (48) hours, the State may, upon notice to Contractor: (a) cease payment of the fees for the affected obligations until Contractor resumes performance of the affected obligations; or (b) immediately terminate this Contract or any purchase order, in whole or in part, without further payment except for fees then due and payable. Contractor will

not increase its charges under this Contract or charge the State any fees other than those provided for in this Contract as the result of a Force Majeure Event.

- D.26. State and Federal Compliance. The Contractor shall comply with all State and federal laws and regulations applicable to Contractor in the Contractor's performance of this Contract.
- D.27. Governing Law. This Contract shall be governed by and construed in accordance with the laws of the State of Tennessee, without regard to its conflict or choice of law rules. The Tennessee Claims Commission or the state or federal courts in Tennessee shall be the venue for all claims, disputes, or disagreements arising under this Contract. The Contractor acknowledges and agrees that any rights, claims, or remedies against the State of Tennessee or its employees arising under this Contract shall be subject to and limited to those rights and remedies available under Tenn. Code Ann. §§ 9-8-101 - 408.
- D.28. Entire Agreement. This Contract is complete and contains the entire understanding between the Parties relating to its subject matter, including all the terms and conditions of the Parties' agreement. This Contract supersedes any and all prior understandings, representations, negotiations, and agreements between the Parties, whether written or oral.
- D.29. Severability. If any terms and conditions of this Contract are held to be invalid or unenforceable as a matter of law, the other terms and conditions of this Contract shall not be affected and shall remain in full force and effect. The terms and conditions of this Contract are severable.
- D.30. Headings. Section headings of this Contract are for reference purposes only and shall not be construed as part of this Contract.
- D.31. Incorporation of Additional Documents. Each of the following documents is included as a part of this Contract by reference. In the event of a discrepancy or ambiguity regarding the Contractor's duties, responsibilities, and performance under this Contract, these items shall govern in order of precedence below:
- a. any amendment to this Contract, with the latter in time controlling over any earlier amendments;
 - b. this Contract with any attachments or exhibits (excluding the items listed at subsections c. through f., below), which includes [identify attachments and exhibits];
 - c. any clarifications of or addenda to the Contractor's proposal seeking this Contract;
 - d. the NASPO solicitation, as may be amended, requesting responses in competition for this Contract;
 - e. any technical specifications provided to proposers during the procurement process to award this Contract; and
 - f. the Contractor's response seeking this Contract.
- D.32. Iran Divestment Act. The requirements of Tenn. Code Ann. § 12-12-101, *et seq.*, addressing contracting with persons as defined at Tenn. Code Ann. §12-12-103(5) that engage in investment activities in Iran, shall be a material provision of this Contract. The Contractor certifies, under penalty of perjury, that to the best of its knowledge and belief that it is not on the list created pursuant to Tenn. Code Ann. § 12-12-106.
- D.33. Insurance. Contractor shall maintain insurance coverage as specified in this Section. The State reserves the right to amend or require additional insurance coverage, coverage amounts, and endorsements required under this Contract. Contractor's failure to maintain or submit evidence of insurance coverage, as required, is a material breach of this Contract. If Contractor loses insurance coverage, fails to renew coverage, or for any reason becomes uninsured during the Term, Contractor shall immediately notify the State. All insurance companies providing coverage must be: (a) acceptable to the State; (b) authorized by the Tennessee Department of Commerce and Insurance ("TDCI"); and (c) rated A- / VII or better by A.M. Best. All coverage must be on a primary basis and noncontributory with any other insurance or self-insurance carried by the State. Contractor agrees to name the State as an additional insured on any insurance policy with the exception of workers' compensation (employer liability) and professional liability (errors and

omissions) insurance. All policies must contain an endorsement for a waiver of subrogation in favor of the State. Any deductible or self insured retention ("SIR") over fifty thousand dollars (\$50,000) must be approved by the State. The deductible or SIR and any premiums are the Contractor's sole responsibility. The Contractor agrees that the insurance requirements specified in this Section do not reduce any liability the Contractor has assumed under this Contract including any indemnification or hold harmless requirements.

To achieve the required coverage amounts, a combination of an otherwise deficient specific policy and an umbrella policy with an aggregate meeting or exceeding the required coverage amounts is acceptable. For example: If the required policy limit under this Contract is for two million dollars (\$2,000,000) in coverage, acceptable coverage would include a specific policy covering one million dollars (\$1,000,000) combined with an umbrella policy for an additional one million dollars (\$1,000,000). If the deficient underlying policy is for a coverage area without aggregate limits (generally Automobile Liability and Employers' Liability Accident), Contractor shall provide a copy of the umbrella insurance policy documents to ensure that no aggregate limit applies to the umbrella policy for that coverage area. In the event that an umbrella policy is being provided to achieve any required coverage amounts, the umbrella policy shall be accompanied by an endorsement at least as broad as the Insurance Services Office, Inc. (also known as "ISO") "Noncontributory—Other Insurance Condition" endorsement or shall be written on a policy form that addresses both the primary and noncontributory basis of the umbrella policy if the State is otherwise named as an additional insured.

Contractor shall provide the State a certificate of insurance ("COI") evidencing the coverages and amounts specified in this Section. The COI must be on a form approved by the TDCI (standard ACORD form preferred). The COI must list each insurer's National Association of Insurance Commissioners (NAIC) number and be signed by an authorized representative of the insurer. The COI must list the State of Tennessee – CPO Risk Manager, 312 Rosa L. Parks Ave., 3rd floor Central Procurement Office, Nashville, TN 37243 as the certificate holder. Contractor shall provide the COI ten (10) business days prior to the Effective Date and again thirty (30) calendar days before renewal or replacement of coverage. Contractor shall provide the State evidence that all subcontractors maintain the required insurance or that subcontractors are included under the Contractor's policy. At any time, the State may require Contractor to provide a valid COI. The Parties agree that failure to provide evidence of insurance coverage as required is a material breach of this Contract. If Contractor self-insures, then a COI will not be required to prove coverage. Instead Contractor shall provide a certificate of self-insurance or a letter, on Contractor's letterhead, detailing its coverage, policy amounts, and proof of funds to reasonably cover such expenses. The State reserves the right to require complete, certified copies of all required insurance policies, including endorsements required by these specifications, at any time.

The State agrees that it shall give written notice to the Contractor as soon as practicable after the State becomes aware of any claim asserted or made against the State, but in no event later than thirty (30) calendar days after the State becomes aware of such claim. The failure of the State to give notice shall only relieve the Contractor of its obligations under this Section to the extent that the Contractor can demonstrate actual prejudice arising from the failure to give notice. This Section shall not grant the Contractor or its insurer, through its attorneys, the right to represent the State in any legal matter, as the right to represent the State is governed by Tenn. Code Ann. § 8-6-106.

The insurance obligations under this Contract shall be: (1)—all the insurance coverage and policy limits carried by the Contractor; or (2)—the minimum insurance coverage requirements and policy limits shown in this Contract; whichever is greater. Any insurance proceeds in excess of or broader than the minimum required coverage and minimum required policy limits, which are applicable to a given loss, shall be available to the State. No representation is made that the minimum insurance requirements of the Contract are sufficient to cover the obligations of the Contractor arising under this Contract. The Contractor shall obtain and maintain, at a minimum, the following insurance coverages and policy limits.

- a. Commercial General Liability ("CGL") Insurance

- 1) The Contractor shall maintain CGL, which shall be written on an ISO Form CG 00 01 occurrence form (or a substitute form providing equivalent coverage) and shall cover liability arising from property damage, premises and operations products and completed operations, bodily injury, personal and advertising injury, and liability assumed under an insured contract (including the tort liability of another assumed in a business contract).

The Contractor shall maintain single limits not less than one million dollars (\$1,000,000) per occurrence. If a general aggregate limit applies, either the general aggregate limit shall apply separately to this policy or location of occurrence or the general aggregate limit shall be twice the required occurrence limit.

b. Workers' Compensation and Employer Liability Insurance

- 1) For Contractors statutorily required to carry workers' compensation and employer liability insurance, the Contractor shall maintain:
 - i. Workers' compensation in an amount not less than one million dollars (\$1,000,000) including employer liability of one million dollars (\$1,000,000) per accident for bodily injury by accident, one million dollars (\$1,000,000) policy limit by disease, and one million dollars (\$1,000,000) per employee for bodily injury by disease.
- 2) If the Contractor certifies that it is exempt from the requirements of Tenn. Code Ann. §§ 50-6-101 – 103, then the Contractor shall furnish written proof of such exemption for one or more of the following reasons:
 - i. The Contractor employs fewer than five (5) employees;
 - ii. The Contractor is a sole proprietor;
 - iii. The Contractor is in the construction business or trades with no employees;
 - iv. The Contractor is in the coal mining industry with no employees;
 - v. The Contractor is a state or local government; or
 - vi. The Contractor self-insures its workers' compensation and is in compliance with the TDCI rules and Tenn. Code Ann. § 50-6-405.

c. Automobile Liability Insurance

- 1) The Contractor shall maintain automobile liability insurance which shall cover liability arising out of any automobile (including owned, leased, hired, and non-owned automobiles).
- 2) The Contractor shall maintain bodily injury/property damage with a limit not less than one million dollars (\$1,000,000) per occurrence or combined single limit.

d. Technology Professional Liability (Errors & Omissions)/Cyber Liability Insurance

- 1) The Contractor shall maintain technology professional liability (errors & omissions)/cyber liability insurance appropriate to the Contractor's profession in an amount not less than ten million dollars (\$10,000,000) per occurrence or claim and ten million dollars (\$10,000,000) annual aggregate, covering all acts, claims,

errors, omissions, negligence, infringement of intellectual property (including copyright, patent and trade secret); network security and privacy risks, including but not limited to unauthorized access, failure of security, information theft, damage to destruction of or alteration of electronic information, breach of privacy perils, wrongful disclosure and release of private information, collection, or other negligence in the handling of confidential information, and including coverage for related regulatory fines, defenses, and penalties.

- 2) Such coverage shall include data breach response expenses, in an amount not less than ten million dollars (\$10,000,000) and payable whether incurred by the State or Contractor, including but not limited to consumer notification, whether or not required by law, computer forensic investigations, public relations and crisis management firm fees, credit file or identity monitoring or remediation services and expenses in the performance of services for the State or on behalf of the State hereunder.

e. Crime Insurance

- 1) The Contractor shall maintain crime insurance, which shall be written on a "loss sustained form" or "loss discovered form" providing coverage for third party fidelity, including cyber theft and extortion. The policy must allow for reporting of circumstances or incidents that may give rise to future claims, include an extended reporting period of no less than two (2) years with respect to events which occurred but were not reported during the term of the policy, and not contain a condition requiring an arrest or conviction.
- 2) Any crime insurance policy shall have a limit not less than one million dollars (\$1,000,000) per claim and one million dollars (\$1,000,000) in the aggregate. Any crime insurance policy shall contain a Social Engineering Fraud Endorsement with a limit of not less than two hundred and fifty thousand dollars (\$250,000). This insurance may be written on a claims-made basis, but in the event that coverage is cancelled or non-renewed, the Contractor shall purchase an extended reporting or "tail coverage" of at least two (2) years after the Term.

D.34. Major Procurement Contract Sales and Use Tax. Pursuant to Tenn. Code Ann. § 4-39-102 and to the extent applicable, the Contractor and the Contractor's subcontractors shall remit sales and use taxes on the sales of goods or services that are made by the Contractor or the Contractor's subcontractors and that are subject to tax.

D.35. Confidentiality of Records. Strict standards of confidentiality of records and information shall be maintained in accordance with applicable state and federal law. All material and information, regardless of form, medium or method of communication, provided to the Contractor by the State or acquired by the Contractor on behalf of the State that is regarded as confidential under state or federal law shall be regarded as "Confidential Information." Nothing in this Section shall permit Contractor to disclose any Confidential Information, regardless of whether it has been disclosed or made available to the Contractor due to intentional or negligent actions or inactions of agents of the State or third parties. Confidential Information shall not be disclosed except as required or permitted under state or federal law. Contractor shall take all necessary steps to safeguard the confidentiality of such material or information in conformance with applicable state and federal law.

The obligations set forth in this Section shall survive the termination of this Contract.

E. SPECIAL TERMS AND CONDITIONS:

E.1. Conflicting Terms and Conditions. Should any of these special terms and conditions conflict with any other terms and conditions of this Contract, the special terms and conditions shall be subordinate to the Contract's other terms and conditions.

- E.2. Statewide Contract. This Contract establishes a source or sources of supply for all Tennessee State Agencies. "Tennessee State Agency" refers to the various departments, institutions, boards, commissions, and agencies of the executive branch of government of the State of Tennessee with exceptions as addressed in Tenn. Comp. R. & Regs. 0690-03-01-.01. The Contractor shall provide all goods or services and deliverables as required by this Contract to all Tennessee State Agencies. The Contractor shall make this Contract available to the following entities, who are authorized to and who may purchase off of this Statewide Contract ("Authorized Users"):
- a. all Tennessee State governmental entities (this includes the legislative branch; judicial branch; and, commissions and boards of the State outside of the executive branch of government);
 - b. Tennessee local governmental agencies;
 - c. members of the University of Tennessee or Tennessee Board of Regents systems;
 - d. any private nonprofit institution of higher education chartered in Tennessee; and,
 - e. any corporation which is exempted from taxation under 26 U.S.C. Section 501(c) (3), as amended, and which contracts with the Department of Mental Health and Substance Abuse to provide services to the public (Tenn. Code Ann. § 33-2-1001).

These Authorized Users may utilize this Contract by purchasing directly from the Contractor according to their own procurement policies and procedures. The State is not responsible or liable for the transactions between the Contractor and Authorized Users.

- E.3. Statewide Contract Reports. All reports shall be submitted electronically in Microsoft Excel format. Reports shall include the ability to sort or summarize data in accordance with the Contract Administrator's specifications. All reports shall be provided at no additional cost to the State.
- a. Quarterly Reports: Contractor(s) will submit quarterly reports to the Contract Administrator no later than thirty (30) days after the end of the State's quarter (e.g. a fiscal year quarter 2 report for October - December is due no later than January 30th). At the Contract Administrator's sole discretion, the State may extend the time allowed to complete quarterly reports. Quarterly reports shall provide statistical data on all purchases under this Contract by Tennessee State Agencies and Authorized Users. At minimum, the quarterly report's statistical data shall be detailed and broken down by line item to include:
 1. Edison contract number
 2. Contract line item number
 3. Invoice date
 4. Invoice number
 5. Supplier part number
 6. Item or bundle description
 7. Quantity purchased
 8. Unit of measure
 9. Unit of measure description
 10. Name of State Agency or Authorized User
 11. Identity of purchaser: State entity or non-State entity
 12. State Agency location
 13. Unit/Contract price per line item
 14. List price as listed in supplier's catalog if catalog item
 15. Subtotals for each category above
 16. Grand totals for each category above
 - b. Custom Reports: When requested by the State, the Contractor shall submit custom reports to the Contract Administrator within thirty (30) days of the request.

- E.4. State of Tennessee Administrative Fee. A one percent (1%) administrative fee will be included in the cost of all goods and/or services purchased under this Contract. This one percent (1%) administrative fee will be rebated back to the State of Tennessee based on quarterly contract

usage of all Authorized Users. The administrative fee is due to the State no later than sixty (60) days after the end of the specified reporting period, as detailed below:

Calendar Quarter 1 (Jan 1-Mar 31)
Calendar Quarter 2 (Apr 1-June 30)
Calendar Quarter 3 (July 1-Sep 30)
Calendar Quarter 4 (Oct 1-Dec 31)

Contractor shall submit payments to:
Ron Plumb, Director of Financial Management
Department of General Services
22nd Floor, William R Snodgrass, Tennessee Tower
312 Rosa L. Parks Avenue
Nashville, TN 37243

Contract usage reports shall be submitted to:
Contract Administrator
Department of General Services
3rd Floor, William R. Snodgrass, Tennessee Tower
312 Rosa L. Parks Avenue
Nashville, TN 37243
Email: CPO.SWC@tn.gov

- E.5. Intellectual Property Indemnity. The Contractor agrees to indemnify and hold harmless the State of Tennessee as well as its officers, agents, and employees from and against any and all claims or suits which may be brought against the State concerning or arising out of any claim of an alleged patent, copyright, trade secret or other intellectual property infringement. In any such claim or action brought against the State, the Contractor shall satisfy and indemnify the State for the amount of any settlement or final judgment, and the Contractor shall be responsible for all legal or other fees or expenses incurred by the State arising from any such claim. The State shall give the Contractor notice of any such claim or suit, however, the failure of the State to give such notice shall only relieve Contractor of its obligations under this Section to the extent Contractor can demonstrate actual prejudice arising from the State's failure to give notice. This Section shall not grant the Contractor, through its attorneys, the right to represent the State of Tennessee in any legal matter, as provided in Tenn. Code Ann. § 8-6-106.
- E.6. Software License Warranty. Contractor grants a license to the State to use all software provided under this Contract in the course of the State's business and purposes.
- E.7. Software Support and Maintenance Warranty. Contractor shall provide to the State all software upgrades, modifications, bug fixes, or other improvements in its software that it makes generally available to its customers.
- E.8. Extraneous Terms and Conditions. Contractor shall fill all orders submitted by the State under this Contract. No purchase order, invoice, or other documents associated with any sales, orders, or supply of any good or service under this Contract shall contain any terms or conditions other than as set forth in the Contract. Any such extraneous terms and conditions shall be void, invalid and unenforceable against the State. Any refusal by Contractor to supply any goods or services under this Contract conditioned upon the State submitting to any extraneous terms and conditions shall be a material breach of the Contract and constitute an act of bad faith by Contractor.
- E.9. Prison Rape Elimination Act (PREA). The Contractor must comply with the Prison Rape Elimination Act (PREA) of 2003 (Federal law 42 U.S.C. 15601 et. seq.), with all applicable Federal PREA standards, and with all State policies and standards related to PREA for preventing, detecting, monitoring, investigating, and eradicating any form of sexual abuse within facilities/programs/offices owned, operated, or contracted.

E.10. Lobbying. The Contractor certifies, to the best of its knowledge and belief, that:

- a. No federally appropriated funds have been paid or will be paid, by or on behalf of the Contractor, to any person for influencing or attempting to influence an officer or employee of an agency, a member of Congress, an officer or employee of Congress, or an employee of a member of Congress in connection with the awarding of any federal contract, the making of any federal grant, the making of any federal loan, the entering into of any cooperative agreement, and the extension, continuation, renewal, amendment, or modification of any federal contract, grant, loan, or cooperative agreement.
- b. If any funds other than federally appropriated funds have been paid or will be paid to any person for influencing or attempting to influence an officer or employee of any agency, a member of Congress, an officer or employee of Congress, or an employee of a member of Congress in connection with any contract, grant, loan, or cooperative agreement, the Contractor shall complete and submit Standard Form-LLL, "Disclosure Form to Report Lobbying," in accordance with its instructions.
- c. The Contractor shall require that the language of this certification be included in the award documents for all sub-awards at all tiers (including subcontracts, sub-grants, and contracts under grants, loans, and cooperative agreements) and that all subrecipients shall certify and disclose accordingly.

This certification is a material representation of fact upon which reliance was placed when this transaction was made or entered into and is a prerequisite for making or entering into this transaction imposed by 31 U.S.C. § 1352.

E.11. Contractor Commitment to Diversity. The Contractor shall comply with and make reasonable business efforts to exceed the commitment to diversity represented by the Contractor's Response to this Participating Addendum (Attachment 2) and resulting in this Contract.

The Contractor shall assist the State in monitoring the Contractor's performance of this commitment by providing, as requested, a monthly report of participation in the performance of this Contract by small business enterprises and businesses owned by minorities, women, service-disabled veterans, and persons with disabilities. Such reports shall be provided to the State of Tennessee Governor's Office of Diversity Business Enterprise in the TN Diversity Software available online at:
<https://tn.diversitysoftware.com/FrontEnd/StartCertification.asp?TN=tn&XID=9810>.

E.12. Partial Takeover of Contract. The State may, at its convenience and without cause, exercise a partial takeover of any service that the Contractor is obligated to perform under this Contract, including any service which is the subject of a subcontract between Contractor and a third party (a "Partial Takeover"). A Partial Takeover of this Contract by the State shall not be deemed a breach of contract. The Contractor shall be given at least thirty (30) days prior written notice of a Partial Takeover. The notice shall specify the areas of service the State will assume and the date the State will be assuming. The State's exercise of a Partial Takeover shall not alter the Contractor's other duties and responsibilities under this Contract. The State reserves the right to withhold from the Contractor any amounts the Contractor would have been paid but for the State's exercise of a Partial Takeover. The amounts shall be withheld effective as of the date the State exercises its right to a Partial Takeover. The State's exercise of its right to a Partial Takeover of this Contract shall not entitle the Contractor to any actual, general, special, incidental, consequential, or any other damages irrespective of any description or amount.

E.13. Unencumbered Personnel. The Contractor shall not restrict its employees, agents, subcontractors or principals who perform services for the State under this Contract from performing the same or similar services for the State after the termination of this Contract, either

as a State employee, an independent contractor, or an employee, agent, subcontractor or principal of another contractor with the State.

- E.14. Personally Identifiable Information. While performing its obligations under this Contract, Contractor may have access to Personally Identifiable Information held by the State ("PII"). For the purposes of this Contract, "PII" includes "Nonpublic Personal Information" as that term is defined in Title V of the Gramm-Leach-Bliley Act of 1999 or any successor federal statute, and the rules and regulations thereunder, all as may be amended or supplemented from time to time ("GLBA") and personally identifiable information and other data protected under any other applicable laws, rule or regulation of any jurisdiction relating to disclosure or use of personal information ("Privacy Laws"). Contractor agrees it shall not do or omit to do anything which would cause the State to be in breach of any Privacy Laws. Contractor shall, and shall cause its employees, agents and representatives to: (i) keep PII confidential and may use and disclose PII only as necessary to carry out those specific aspects of the purpose for which the PII was disclosed to Contractor and in accordance with this Contract, GLBA and Privacy Laws; and (ii) implement and maintain appropriate technical and organizational measures regarding information security to: (A) ensure the security and confidentiality of PII; (B) protect against any threats or hazards to the security or integrity of PII; and (C) prevent unauthorized access to or use of PII. Contractor shall immediately notify State: (1) of any disclosure or use of any PII by Contractor or any of its employees, agents and representatives in breach of this Contract; and (2) of any disclosure of any PII to Contractor or its employees, agents and representatives where the purpose of such disclosure is not known to Contractor or its employees, agents and representatives. The State reserves the right to review Contractor's policies and procedures used to maintain the security and confidentiality of PII and Contractor shall, and cause its employees, agents and representatives to, comply with all reasonable requests or directions from the State to enable the State to verify or ensure that Contractor is in full compliance with its obligations under this Contract in relation to PII. Upon termination or expiration of the Contract or at the State's direction at any time in its sole discretion, whichever is earlier, Contractor shall immediately return to the State any and all PII which it has received under this Contract and shall destroy all records of such PII.

The Contractor shall report to the State any instances of unauthorized access to or potential disclosure of PII in the custody or control of Contractor ("Unauthorized Disclosure") that come to the Contractor's attention. Any such report shall be made by the Contractor within twenty-four (24) hours after the Unauthorized Disclosure has come to the attention of the Contractor. Contractor shall take all necessary measures to halt any further Unauthorized Disclosures. The Contractor, at the sole discretion of the State, shall provide no cost credit monitoring services for individuals whose PII was affected by the Unauthorized Disclosure. The Contractor shall bear the cost of notification to all individuals affected by the Unauthorized Disclosure, including individual letters and public notice. The remedies set forth in this Section are not exclusive and are in addition to any claims or remedies available to this State under this Contract or otherwise available at law. The obligations set forth in this Section shall survive the termination of this Contract.

- E.15. Federal Funding Accountability and Transparency Act (FFATA). This Contract requires the Contractor to provide supplies or services that are funded in whole or in part by federal funds that are subject to FFATA. The Contractor is responsible for ensuring that all applicable requirements, including but not limited to those set forth herein, of FFATA are met and that the Contractor provides information to the State as required.

The Contractor shall comply with the following:

- a. Reporting of Total Compensation of the Contractor's Executives.
 - (1) The Contractor shall report the names and total compensation of each of its five most highly compensated executives for the Contractor's preceding completed fiscal year, if in the Contractor's preceding fiscal year it received:

- i. 80 percent or more of the Contractor's annual gross revenues from federal procurement contracts and federal financial assistance subject to the Transparency Act, as defined at 2 CFR 170.320 (and subawards); and
- ii. \$25,000,000 or more in annual gross revenues from federal procurement contracts (and subcontracts), and federal financial assistance subject to the Transparency Act (and subawards); and
- iii. The public does not have access to information about the compensation of the executives through periodic reports filed under section 13(a) or 15(d) of the Securities Exchange Act of 1934 (15 U.S.C. 78m(a), 78o(d)) or section 6104 of the Internal Revenue Code of 1986. (To determine if the public has access to the compensation information, see the U.S. Securities and Exchange Commission total compensation filings at <http://www.sec.gov/answers/excomp.htm>).

As defined in 2 C.F.R. § 170.315, "Executive" means officers, managing partners, or any other employees in management positions.

- (2) Total compensation means the cash and noncash dollar value earned by the executive during the Contractor's preceding fiscal year and includes the following (for more information see 17 C.F.R. § 229.402(c)(2)):

- i. Salary and bonus.
- ii. Awards of stock, stock options, and stock appreciation rights. Use the dollar amount recognized for financial statement reporting purposes with respect to the fiscal year in accordance with the Statement of Financial Accounting Standards No. 123 (Revised 2004) (FAS 123R), Shared Based Payments.
- iii. Earnings for services under non-equity incentive plans. This does not include group life, health, hospitalization or medical reimbursement plans that do not discriminate in favor of executives, and are available generally to all salaried employees.
- iv. Change in pension value. This is the change in present value of defined benefit and actuarial pension plans.
- v. Above-market earnings on deferred compensation which is not tax qualified.
- vi. Other compensation, if the aggregate value of all such other compensation (e.g. severance, termination payments, value of life insurance paid on behalf of the employee, perquisites or property) for the executive exceeds \$10,000.

- b. The Contractor must report executive total compensation described above to the State by the end of the month during which this Contract is awarded.
- c. If this Contract is amended to extend the Term, the Contractor must submit an executive total compensation report to the State by the end of the month in which the term extension becomes effective.
- d. The Contractor will obtain a Data Universal Numbering System (DUNS) number and maintain its DUNS number for the term of this Contract. More information about obtaining a DUNS Number can be found at: <http://fedgov.dnb.com/webform/>

The Contractor's failure to comply with the above requirements is a material breach of this Contract for which the State may terminate this Contract for cause. The State will not be obligated to pay any outstanding invoice received from the Contractor unless and until the Contractor is in full compliance with the above requirements.

- E.16. Clean Air Act and Federal Water Pollution Control Act. If applicable, and as a condition for receipt of federal awards, the Contractor agrees to comply with the Clean Air Act, 42 U.S.C. § 7401 *et*

seq. and the Federal Water Pollution Control Act, 33 U.S.C § 1251 *et seq.*, as those sections are amended from time to time during the term. Violations must be reported to FEMA and the Region 4 Office of the Environmental Protection Agency.

- E.17. Drug-Free Workplace. The Contractor shall provide a drug-free workplace pursuant to the Drug-Free Workplace Act of 1988, Title 41 U.S.C. §§ 701, *et seq.*, and the regulations in Title 41 U.S.C.A. §§ 8101 through 8106.
- E.18. Procurement of Recovered Materials. If applicable:
- a) In the Performance of this contract, the Contractor shall make maximum use of products containing recovered materials that are EPA-designated items unless the product cannot be acquired competitively within a timeframe providing for compliance with the contract performance schedule; meeting contract performance requirements; or at a reasonable price.
 - b) Information about this requirement, along with the list of EPA-designated items, is available at EPA's Comprehensive.
 - c) Procurement Guidelines website, <https://www.epa.gov/smm/comprehensive-procurement-guideline-cpg-program>.
 - d) The Contractor also agrees to comply with all other applicable requirements of Section 6002 of the Solid Waste Disposal Act.
- E.19. Access to Records. If FEMA funds are used in whole or in part:
- a) The Contractor agrees to provide the State, the FEMA Administrator, the Comptroller General of the United States, or any of their authorized representatives access to any books, documents, papers, and records of the Contractor which are directly pertinent to this contract for purposes of making audits, examinations, excerpts, and transcriptions.
 - b) The Contractor agrees to permit any of the foregoing parties to reproduce by any means whatsoever or to copy excerpts and transcriptions as reasonably needed.
 - c) The Contractor agrees to provide the FEMA Administrator or his authorized representatives access to construction or other work sites pertaining to the work being completed under the contract.
 - d) In Compliance with the Disaster Recovery Act of 2018, the State and the Contractor acknowledge and agree that no language in this contract is intended to prohibit the audits or internal reviews by the FEMA Administrator or the Comptroller General of the United States.
- E.20. Use of DHS Logo. The contractor shall not use the DHS seal(s), logos, crests, or reproductions of flags or likenesses of DHS agency officials without specific FEMA pre-approval.
- E.21. Compliance with Federal Law, Regulations, and Executive Orders. This is an acknowledgement that FEMA financial assistance will be used to fund all or a portion of the contract. The contractor will comply with all applicable Federal law, regulations, executive orders, FEMA policies, procedures, and directives.
- E.22. Compliance with The False Claims Act. The Contractor acknowledges that 31 U.S.C. Chap. 38 (Administrative Remedies for False Claims and Statements) applies to the Contractor's actions pertaining to this contract.
- E.23. No Obligation by Federal Government. The Federal Government is not a party to this contract and is not subject to any obligations or liabilities to the non-Federal entity, contractor, or any other party pertaining to any matter resulting from the Contract.
- E.24. Equal Employment Opportunity. During the performance of this Contract, the Contractor agrees as follows:

- a. The Contractor will not discriminate against any employee or applicant for employment because of race, color, religion, sex, sexual orientation, gender identity, or national origin. The Contractor will take affirmative action to ensure that applicants are employed, and that employees are treated during employment, without regard to their race, color, religion, sex, sexual orientation, gender identity, or national origin. Such action shall include, but not be limited to the following: Employment, upgrading, demotion, or transfer, recruitment or recruitment advertising; layoff or termination; rates of pay or other forms of compensation; and selection for training, including apprenticeship. The Contractor agrees to post in conspicuous places, available to employees and applicants for employment, notices to be provided by the contracting officer setting forth the provisions of this nondiscrimination clause.
- b. The Contractor will, in all solicitations or advertisements for employees placed by or on behalf of the Contractor, state that all qualified applicants will receive consideration for employment without regard to race, color, religion, sex, sexual orientation, gender identity, or national origin.
- c. The Contractor will not discharge or in any other manner discriminate against any employee or applicant for employment because such employee or applicant has inquired about, discussed, or disclosed the compensation of the employee or applicant or another employee or applicant. This provision shall not apply to instances in which an employee who has access to the compensation information of other employees or applicants as a part of such employee's essential job functions discloses the compensation of such other employees or applicants to individuals who do not otherwise have access to such information, unless such disclosure is in response to a formal complaint or charge, in furtherance of an investigation, proceeding, hearing, or action, including an investigation conducted by the employer, or is consistent with the contractor's legal duty to furnish information.
- d. The Contractor will send to each labor union or representative of workers with which it has a collective bargaining agreement or other contract or understanding, a notice to be provided by the agency contracting officer, advising the labor union or workers' representative of the contractor's commitments under section 202 of Executive Order 11246 of September 24, 1965, and shall post copies of the notice in conspicuous places available to employees and applicants for employment.
- e. The Contractor will comply with all provisions of Executive Order 11246 of September 24, 1965, and of the rules, regulations, and relevant orders of the Secretary of Labor.
- f. The Contractor will furnish all information and reports required by Executive Order 11246 of September 24, 1965, and by the rules, regulations, and orders of the Secretary of Labor, or pursuant thereto, and will permit access to his books, records, and accounts by the contracting agency and the Secretary of Labor for purposes of investigation to ascertain compliance with such rules, regulations, and orders.
- g. In the event of the Contractor's non-compliance with the nondiscrimination clauses of this contract or with any of such rules, regulations, or orders, this contract may be canceled, terminated or suspended in whole or in part and the contractor may be declared ineligible for further Government contracts in accordance with procedures authorized in Executive Order 11246 of September 24, 1965, and such other sanctions may be imposed and remedies invoked as provided in Executive Order 11246 of September 24, 1965, or by rule, regulation, or order of the Secretary of Labor, or as otherwise provided by law.
- h. The Contractor will include the portion of the sentence immediately preceding paragraph (1) and the provisions of paragraphs (1) through (8) in every subcontract or purchase order unless exempted by rules, regulations, or orders of the Secretary of Labor issued pursuant to section 204 of Executive Order 11246 of September 24, 1965, so that such provisions will be binding upon each subcontractor or vendor. The Contractor will take such action with respect to any subcontract or purchase order as the administering agency may direct as a means of enforcing such provisions, including sanctions for noncompliance:

Provided, however, that in the event a contractor becomes involved in, or is threatened with, litigation with a subcontractor or vendor as a result of such direction by the administering agency, the contractor may request the United States to enter into such litigation to protect the interests of the United States.

The applicant further agrees that it will be bound by the above equal opportunity clause with respect to its own employment practices when it participates in federally assisted construction work: Provided, That if the applicant so participating is a State or local government, the above equal opportunity clause is not applicable to any agency, instrumentality or subdivision of such government which does not participate in work on or under the contract.

The applicant agrees that it will assist and cooperate actively with the administering agency and the Secretary of Labor in obtaining the compliance of contractors and subcontractors with the equal opportunity clause and the rules, regulations, and relevant orders of the Secretary of Labor, that it will furnish the administering agency and the Secretary of Labor such information as they may require for the supervision of such compliance, and that it will otherwise assist the administering agency in the discharge of the agency's primary responsibility for securing compliance.

The applicant further agrees that it will refrain from entering into any contract or contract modification subject to Executive Order 11246 of September 24, 1965, with a contractor debarred from, or who has not demonstrated eligibility for, Government contracts and federally assisted construction contracts pursuant to the Executive Order and will carry out such sanctions and penalties for violation of the equal opportunity clause as may be imposed upon contractors and subcontractors by the administering agency or the Secretary of Labor pursuant to Part II, Subpart D of the Executive Order. In addition, the applicant agrees that if it fails or refuses to comply with these undertakings, the administering agency may take any or all of the following actions: Cancel, terminate, or suspend in whole or in part this grant (contract, loan, insurance, guarantee); refrain from extending any further assistance to the applicant under the program with respect to which the failure or refund occurred until satisfactory assurance of future compliance has been received from such applicant; and refer the case to the Department of Justice for appropriate legal proceedings.

E.25. Contractor Hosted Services Confidential Data, Audit, and Other Requirements.

- a. "Confidential State Data" is defined as data deemed confidential by State or Federal statute or regulation. The Contractor shall protect Confidential State Data as follows:
 - (1) The Contractor shall ensure that all Confidential State Data is housed in the continental United States, inclusive of backup data.
 - (2) The Contractor shall encrypt Confidential State Data at rest and in transit using the current version of Federal Information Processing Standard ("FIPS") 140-2 validated encryption technologies.
 - (3) The Contractor and the Contractor's processing environment containing Confidential State Data shall either (1) be in accordance with at least one of the following security standards: (i) International Standards Organization ("ISO") 27001; (ii) Federal Risk and Authorization Management Program ("FedRAMP"); or (2) be subject to an annual engagement by a CPA firm in accordance with the standards of the American Institute of Certified Public Accountants ("AICPA") for a System and Organization Controls for service organizations ("SOC") Type II audit. The State shall approve the SOC audit control objectives. The Contractor shall provide proof of current ISO certification or FedRAMP authorization for the Contractor and Subcontractor(s), or provide the State with the Contractor's and Subcontractor's annual SOC Type II audit report within 30 days from when the CPA firm provides the audit report to the

Contractor or Subcontractor. The Contractor shall submit corrective action plans to the State for any issues included in the audit report within 30 days after the CPA firm provides the audit report to the Contractor or Subcontractor.

If the scope of the most recent SOC audit report does not include all of the current State fiscal year, upon request from the State, the Contractor must provide to the State a letter from the Contractor or Subcontractor stating whether the Contractor or Subcontractor made any material changes to their control environment since the prior audit and, if so, whether the changes, in the opinion of the Contractor or Subcontractor, would negatively affect the auditor's opinion in the most recent audit report.

No additional funding shall be allocated for these certifications, authorizations, or audits as these are included in the Maximum Liability of this Contract.

- (4) The Contractor must annually perform Penetration Tests and Vulnerability Assessments against its Processing Environment. "Processing Environment" shall mean the combination of software and hardware on which the Application runs. "Application" shall mean the computer code that supports and accomplishes the State's requirements as set forth in this Contract. "Penetration Tests" shall be in the form of attacks on the Contractor's computer system, with the purpose of discovering security weaknesses which have the potential to gain access to the Processing Environment's features and data. The "Vulnerability Assessment" shall be designed and executed to define, identify, and classify the security holes (vulnerabilities) in the Processing Environment. The Contractor shall allow the State, at its option, to perform Penetration Tests and Vulnerability Assessments on the Processing Environment.
- (5) Contractor shall be certified to host Payment Card Industry ("PCI") data in accordance with the current version of PCI DSS ("Data Security Standard"), maintained by the PCI Security Standards Council.
- (6) Upon termination of this Contract and in consultation with the State, the Contractor shall destroy all Confidential State Data it holds (including any copies such as backups) in accordance with the current version of National Institute of Standards and Technology ("NIST") Special Publication 800-88. The Contractor shall provide a written confirmation of destruction to the State within ten (10) business days after destruction.

b. Minimum Requirements

- (1) The Contractor and all data centers used by the Contractor to host State data, including those of all Subcontractors, must comply with the State's Enterprise Information Security Policies as amended periodically. The State's Enterprise Information Security Policies document is found at the following URL: <https://www.tn.gov/finance/strategic-technology-solutions/strategic-technology-solutions/sts-security-policies.html>.
- (2) The Contractor agrees to maintain the Application so that it will run on a current, manufacturer-supported Operating System. "Operating System" shall mean the software that supports a computer's basic functions, such as scheduling tasks, executing applications, and controlling peripherals.
- (3) If the Application requires middleware or database software, Contractor shall maintain middleware and database software versions that are at all times fully compatible with current versions of the Operating System and Application to ensure that security vulnerabilities are not introduced.

c. Comptroller Audit Requirements

Upon reasonable notice and at any reasonable time, the Contractor and Subcontractor(s) agree to allow the State, the Comptroller of the Treasury, or their duly appointed representatives to perform information technology control audits of the Contractor and all Subcontractors used by the Contractor. Contractor will maintain and cause its Subcontractors to maintain a complete audit trail of all transactions and activities in connection with this Contract. Contractor will provide to the State, the Comptroller of the Treasury, or their duly appointed representatives access to Contractor and Subcontractor(s) personnel for the purpose of performing the information technology control audit.

The information technology control audit may include a review of general controls and application controls. General controls are the policies and procedures that apply to all or a large segment of the Contractor's or Subcontractor's information systems and applications and include controls over security management, access controls, configuration management, segregation of duties, and contingency planning. Application controls are directly related to the application and help ensure that transactions are complete, accurate, valid, confidential, and available. The audit shall include the Contractor's and Subcontractor's compliance with the State's Enterprise Information Security Policies and all applicable requirements, laws, regulations or policies.

The audit may include interviews with technical and management personnel, physical inspection of controls, and review of paper or electronic documentation.

For any audit issues identified, the Contractor and Subcontractor(s) shall provide a corrective action plan to the State within 30 days from the Contractor or Subcontractor receiving the audit report.

Each party shall bear its own expenses incurred while conducting the information technology controls audit.

- d. Business Continuity Requirements. The Contractor shall maintain set(s) of documents, instructions, and procedures which enable the Contractor to respond to accidents, disasters, emergencies, or threats without any stoppage or hindrance in its key operations ("Business Continuity Requirements"). Business Continuity Requirements shall include:
- (1) "Disaster Recovery Capabilities" refer to the actions the Contractor takes to meet the Recovery Point and Recovery Time Objectives defined below. Disaster Recovery Capabilities shall meet the following objectives:
 - i. Recovery Point Objective ("RPO"). The RPO is defined as the maximum targeted period in which data might be lost from an IT service due to a major incident: [number of hours/minutes]
 - ii. Recovery Time Objective ("RTO"). The RTO is defined as the targeted duration of time and a service level within which a business process must be restored after a disaster (or disruption) in order to avoid unacceptable consequences associated with a break in business continuity: [number of hours/minutes]
 - (2) The Contractor and any Subcontractor(s) shall perform at least one Disaster Recovery Test every three hundred sixty-five (365) days. A "Disaster Recovery Test" shall mean the process of verifying the success of the restoration procedures that are executed after a critical IT failure or disruption occurs. The Disaster Recovery Test shall use actual State Data Sets that mirror production

data, and success shall be defined as the Contractor verifying that the Contractor can meet the State's RPO and RTO requirements. A "Data Set" is defined as a collection of related sets of information that is composed of separate elements but can be manipulated as a unit by a computer. The Contractor shall provide written confirmation to the State after each Disaster Recovery Test that its Disaster Recovery Capabilities meet the RPO and RTO requirements.

- E.26. Printing Authorization. The Contractor agrees that no publication coming within the jurisdiction of Tenn. Code Ann. §§ 12-7-101, *et. seq.*, shall be printed pursuant to this Contract unless a printing authorization number has been obtained and affixed as required by Tenn. Code Ann. § 12-7-103 (d).
- E.27. Survival. The terms, provisions, representations, and warranties contained in this Contract which by their sense and context are intended to survive the performance and termination of this Contract, shall so survive the completion of performance and termination of this Contract.
- E.28. Prohibition on Certain Telecommunications and Video Surveillance Services or Equipment. If applicable and as required by 2 CFR 200.216, Contractor is prohibited from obligating or expending loan or grant funds to procure or obtain; extend or renew a contract to procure or obtain; or enter into a contract (or extend or renew a contract) to procure or obtain equipment, services, or systems that uses covered telecommunications equipment or services as a substantial or essential component of any system, or as a critical technology as part of any system. As described in Public Law 115-232, Section 889, "covered telecommunications equipment" is as follows:
- a. Telecommunications equipment produced by Huawei Technologies Company or ZTE Corporation (or any subsidiary or affiliate of such entities).
 - b. For the purpose of public safety, security of government facilities, physical security surveillance of critical infrastructure, and other national security purposes, video surveillance and telecommunications equipment produced by Hytera Communications Corporation, Hangzhou Hikvision Digital Technology Company, or Dahua Technology Company (or any subsidiary or affiliate of such entities).
 - c. Telecommunications or video surveillance services provided by such entities or using such equipment.

Telecommunications or video surveillance equipment or services produced or provided by an entity that the Secretary of Defense, in consultation with the Director of the National Intelligence or the Director of the Federal Bureau of Investigation, reasonably believes to be an entity owned or controlled by, or otherwise connected to, the government of a covered foreign country

IN WITNESS WHEREOF,

CONTRACTOR LEGAL ENTITY NAME:

CONTRACTOR SIGNATURE

DATE

PRINTED NAME AND TITLE OF CONTRACTOR SIGNATORY (above)

STATE OF TENNESSEE, CENTRAL PROCUREMENT OFFICE:

MICHAEL F. PERRY, CHIEF PROCUREMENT OFFICER

DATE

ATTESTATION RE PERSONNEL USED IN CONTRACT PERFORMANCE

<p>If the attestation applies to more than one contract, modify this row accordingly.</p> <p>SUBJECT CONTRACT NUMBER:</p>	
<p>CONTRACTOR LEGAL ENTITY NAME:</p>	
<p>EDISON VENDOR IDENTIFICATION NUMBER:</p>	

If the attestation applies to more than one contract, modify the following paragraph accordingly.

The Contractor, identified above, does hereby attest, certify, warrant, and assure that the Contractor shall not knowingly utilize the services of an illegal immigrant in the performance of this Contract and shall not knowingly utilize the services of any subcontractor who will utilize the services of an illegal immigrant in the performance of this Contract.

CONTRACTOR SIGNATURE

NOTICE: This attestation MUST be signed by an individual empowered to contractually bind the Contractor. Attach evidence documenting the individual's authority to contractually bind the Contractor, unless the signatory is the Contractor's chief executive or president.

PRINTED NAME AND TITLE OF SIGNATORY

DATE OF ATTESTATION

GOVERNOR'S OFFICE OF DIVERSITY BUSINESS ENTERPRISE

Efforts to Achieve Diversity Business Participation

The Governor's Office of Diversity Business Enterprise ("Go-DBE") is the State's central point of contact to attract and assist minority-owned, woman-owned, service-disabled veteran-owned, disabled-owned, and small business enterprises interested in competing in the State of Tennessee's procurement and contracting activities. These diversity business enterprises are defined as follows:

Minority Business Enterprise (MBE) and Woman Business Enterprise (WBE)

Businesses that are a continuing, independent, for-profit business which performs a commercially useful function, and is at least fifty-one percent (51%) owned and controlled by one (1) or more individuals in the minority or woman category who were impeded from normal entry into the economic mainstream because of past practices of discrimination based on race, ethnic background, or gender.

Service-Disabled Veteran Business Enterprise (SDVBE)

"Service-disabled veteran-owned business" means a service-disabled veteran-owned business located in the State of Tennessee that satisfies the criteria in Tenn. Code. Ann. § 12-3-1102(8).

"Service-disabled veteran" means any person who served honorably in active duty in the armed forces of the United States with at least a twenty percent (20%) disability that is service-connected, i.e., the disability was incurred or aggravated in the line of duty in the active military, naval or air service.

Small Business Enterprise (SBE)

"Small business" means a business that is a continuing, independent, for profit business which performs a commercially useful function with residence in Tennessee and has total gross receipts of no more than ten million dollars (\$10,000,000) averaged over a three-year period or employs no more than ninety-nine (99) persons on a full-time basis.

"Disabled Business Enterprise (DSBE)

"Disabled Business Enterprise" means a business owned by a person with a disability that is a continuing, independent, for-profit business that performs a commercially useful function, and is at least fifty-one (51%) owned and controlled by one (1) or more persons with a disability, or, in the case of any publicly-owned business, at least fifty one percent (51%) of the stock of which is owned and controlled by one(1) or more persons with a disability and whose management and daily business operations are under the control of one (1) or more persons with a disability.

For additional program eligibility information, visit:

<https://www.tn.gov/generalservices/procurement/central-procurement-office--cpo-/governor-s-office-of-diversity-business-enterprise--godbe--/program-eligibility.html>

Instructions

As part of this Invitation to Bid, the respondent should complete the Diversity Utilization Plan below. To assist in your effort to seek and solicit the participation of diversity businesses on this solicitation, a directory of certified Diversity Business Enterprise firms may be found on the State's website at: <https://tn.diversitysoftware.com/FrontEnd/VendorSearchPublic.asp?TN=tn&XID=1215> directory or by calling Go-DBE toll free at 866-894-5026.

RESPONDENT'S DIVERSITY UTILIZATION PLAN

Respondent's Company Name:		
Solicitation Event Name:		Event Number:
Respondent's Contact Name:	Phone: ()	Email:
Does the Respondent qualify as the diversity business enterprise? ___ Yes ___ No		
If yes, which designation does the Respondent qualify? ___ MBE ___ WBE ___ DSBE ___ SDVBE ___ SBE		
Certifying Agency:		

Estimated level of participation by DBEs if awarded a contract pursuant to this ITB:

Diversity Business Information (List all subcontractors, joint-ventures, and suppliers)	% of Contract	Estimated Amount	MBE/ WBE/ SDVBE/ SBE / DSBE Designation	Currently Certified (Yes or No)
Business Name:				
Contact Name:				
Contact Phone:				
Business Name:				
Contact Name:				
Contact Phone:				

If awarded a contract, we confirm our commitment to make reasonable business efforts to meet or exceed the commitment to diversity as represented in our Diversity Utilization Plan. We shall assist the State in monitoring our performance of this commitment by providing, as requested, a monthly report of participation in the performance of this Contract by small business enterprises and businesses owned by minorities, women, service-disabled veterans and persons with disabilities. Such reports shall be provided to the state of Tennessee Governor's Office of Diversity Business Enterprise in the TN Diversity Software available online at:

<https://tn.diversitysoftware.com/FrontEnd/StartCertification.asp?TN=tn&XID=9810>

We further agree to request in writing and receive prior approval from the Central Procurement Office for any changes to the use of the above listed diversity businesses.

Authorized Signature: _____ Date: _____

Printed Name and Title of Signatory _____



ARIZONA DEPARTMENT OF
ADMINISTRATION STATE
PROCUREMENT OFFICE

DETERMINATION

TITLE

Contract Award and Award Basis (Revised 3.15.2022)

AUTHORITY

A.R.S. §41-2534 Competitive sealed proposals; A.A.C. R2-7-702 Determination of Fair and Reasonable Price; and A.A.C. R2-7-C317 Contract Award

SOLICITATION

No.: BPM003137

Description: Mailing Equipment, Supplies, and Maintenance

EVALUATION:

The Arizona State Procurement Office issued the solicitation on 7/6/2021 at 12:00 AM through the State e-Procurement System. Initial Offers were due on 9/8/2021 at 5:00 PM. The State Procurement Office received nine (9) proposals electronically via the State e- Procurement System on or before the due date and time.

Offers were received from the following:

- Bell and Howell LLC
- DMT Solutions Global Corporation
- Fluence Automation LLC
- Francotyp-Postalia Inc.
- Kern USA LLC
- OPEX
- Pitney Bowes
- Quadient Inc.
- RISO Inc.

A Multi-state Evaluation Committee, who were determined to have the qualifications and expertise needed, participated in the evaluation. The Evaluation Committee member(s) consisted of, Corey Korn and Nick Watson (Texas), Julie Matthews and Michael Wong (California), and Janet DeIGreco and Madelyne Colon (Connecticut). Nyasha Daley from the State Procurement Office presided as the Facilitator for the evaluations. Ted Fosket and Joel Atkinson from NASPO ValuePoint functioned as the team's sponsors.

The committee based their evaluation on a detailed evaluation scoring rubric which covered:

- Experience and Capacity
- Methodology
- Pricing

The committee evaluated the proposals on a 1000 point scale. Pricing scores were determined based on a

relative scale, determined by the expected benchmark.

Below are the scoring summaries:

Offeror	Experience and Capacity (Max Points 500)	Methodology (Max Points 300)	Pricing (Max Points 200)	Total Points (Max Points 100)
Bell and Howell LLC	375	225	80	680
DMT Solutions Global Corporation	500	300	150	950
Fluence Automation LLC	375	225	150	750
Francotyp-Postalia Inc.	375	225	80	750
Kern USA LLC	200	225	200	625
OPEX	500	225	80	805
Pitney Bowes	500	300	200	1000
Quadient Inc.	500	300	150	950
RISO Inc.	200	120	150	470

Determination

Pursuant to A.A.C. R2-702 Determination of Fair and Reasonable Price, it is hereby determined that the achieved price is fair and reasonable;

Further, in accordance with A.R.S. §41-2534 and A.A.C. R2-7-C317, it is hereby determined that entering into contract(s) with the following offeror(s) is most advantageous to the state based on the evaluation factors set for the in the aforementioned solicitation.

- Bell and Howell LLC
- DMT Solutions Global Corporation
- Fluence Automation LLC
- Francotyp-Postalia Inc.
- OPEX
- Pitney Bowes
- Quadient Inc.

Basis for Award

Solicitation No. BPM003137 was conducted pursuant to A.R.S. § 41-2534 and implementing rules. The achieved pricing was the result of adequate price competition under Solicitation No. BPM003137 and comparisons to benchmarks.

Any questions regarding the outcome of this Solicitation or resultant contracts may be directed to the Procurement Officer of record for this solicitation.

DOCUMENTATION

This determination shall be placed in the procurement file.

EFFECTIVE

This determination is effective and shall remain in effect unless otherwise modified or revoked.

Nyasha Daley

Signature
Nyasha Daley, PhD
Statewide Procurement Manager

11/18/2021
Date

iX-1

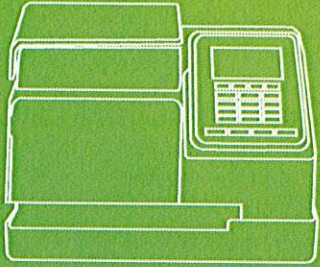

Mailing Systems

The complete and compliant choice for small or home office



BACKED BY THE EXPERTS
Gartner, IDC, Forrester, and Aspire



EXPERIENCE
A rich history of world-class leadership



PROVEN RESULTS
97% customer satisfaction rate



EXPERTISE
7 trillion personalized experiences annually

Are you ready for decertification?

On December 31, 2024, the USPS® plans to discontinue all postage meters that are not IMI (Intelligent Mail Indicia) compliant.

QUADIENT
01/28/2022

FIRST-CLASS MAIL

US POSTAGE \$000.50 0



SPECIMEN ZIP 06461
046M12345678

OUTGOING: IBI indicia example



quadiënt
FIRST-CLASS MAIL
IMI
\$000.60 0
01/25/2023 ZIP 06461
043M31213010

US POSTAGE

NEW: IMI indicia example

The iX-1 postage meter with its new sleek design and user-friendly interface is fully IMI compliant and USPS® approved.

- Meet USPS® requirements
- Enhance security and ensure postage accuracy
- Avoid interrupted mail service

Mailers are encouraged to adopt new machines by June 2024 in order to not miss the deadline.



Quadiënt's iX-1 Series postage meter combines mail and parcel processing into one easy solution. With a full set of standard features and innovative apps, nothing delivers like the iX-1.

IMI printing technology

Perfect for your small business or home office, Quadiënt's iX-1 has Intelligent Mail Indicia (IMI) printing technology, soon to be a mandatory requirement of the USPS®. While most postage meters today generate IBI (Information-Based Indicia), IMI technology offers enhanced security and increased postage accuracy.

Take the guesswork out of postage

With a standard 10 lb. scale, the iX-1 can automatically weigh and calculate postage values guaranteeing you pay the correct amount for every item you send, every time. Never guess the price or overpay for postage again.

Avoid time-consuming trips to the post office

Process mail and parcels from the convenience of your office. Access over 50 USPS® rates and services including First-Class Mail®, Priority Mail® and Certified Mail™. With an iX-1, you will receive timely USPS® rate updates and be able to print postage 24/7.

Personalize your mail

Increase open rates and help promote your business with ad slogans, custom text messages and company logos with just the click of a few buttons.

Streamline shipping processes with Neoship ADVANCED

Quadiënt's online shipping software enables multi-carrier shipping and so much more. Automatically compare rates across USPS®, FedEx® or UPS®* to find the lowest cost or fastest delivery time to get your parcels to their final destination. The single screen interface is easy to use, saves you time, and makes rate shopping a breeze. Neoship meets the latest USPS® IM®pb (Intelligent Mail® package barcode) requirements. Also receive the following benefits:

- Qualify for discounted postage rates with Commercial Base Pricing
- Get FREE address correction services
- Access FREE insurance - Priority Mail® (up to \$100 value) and Priority Mail Express™ (up to \$100 value)
- Generate detailed reports based on shipment history/operator shipments/transactions



Powerful performance in a compact design

Detachable 10 lb. scale



Rate Wizard

Shortcut keys

Greater weighing capacity for mail and parcels

The IX-1 is equipped with a 10-pound scale that may be removed to accurately weigh larger items. Weigh a wide range of mail, including letters, flats, small parcels and more. From postcards to packages, this scale handles it all.

Rate Wizard simplifies postage rate selection

The Rate Wizard simplifies the process of selecting the correct postal rate and class for your items. With clear step-by-step instructions, the selection process has never been easier.

Eliminate keystrokes with shortcut keys

Shortcut keys are easy to program and save time enabling you to create one-touch access to your most frequently used rates and services. Choose the most commonly used postal rates as well as customize and save the settings for your most frequent jobs.

Easy set up

The IX-1 postage meter comes with a quick assembly guide and "how-to-use" video tutorials to get you up and running in no time. Connect to any network through a high-speed LAN connection. Enjoy fast, automated statistic uploads, postage rate updates, and postage refills.

Do more with a complimentary Myquadiant account

This online portal helps you manage your postage account. Track postage usage, buy supplies, view and pay Quadiant invoices right from your browser. Myquadiant provides quick answers and the convenience of a one stop shop for all your postage needs.

The perfect addition to your small business

With its innovative design and amazing standard features, the IX-1 is the simple yet powerful choice to handle the mail processing and shipping needs of your small business or home office. Contact a Quadiant mailing expert to learn more about the IX-1.



SPECIFICATIONS

Processing speed	Up to 18 letters per minute (lpm)
Envelope minimum	3.5" x 5"
Envelope maximum	12" x 15"
Envelope thickness	5/16"
Feeding capability	Manual
Envelope orientation	Landscape or portrait
Default rate settings	Standard
Postage meter tapes	Standard
Rate Wizard	Standard
Rate shortcut keys	6
Job imprint memories	9
Weighing platform (Integrated)	10 lb. standard. Can be removed for larger packages
Ad slogans	8
Personalized text messages	10 custom
Postal mail class inscriptions	Automatic
Incoming mail date stamp	Standard
4-digit PIN code	Yes, up to 10 with optional account upgrade
Account tracking	1 account standard; 5 to 10 available
Online postage usage reporting	Standard
Connectivity	LAN Standard
Low ink email alerts	Standard
OPTIONS	
Neoship	Available
Neoship ADVANCED (multi-carrier)	Available
Quadient Postage Funding	Available
Neostats	Available
USB memory key	Available
External USB printer	Available
Connectivity/Wireless	Available
SYSTEM DIMENSIONS	
	Length x Depth x Height
IX-1	12.6" x 8.7" x 8.5"
IX-1 with integrated scale	8.6 lbs.

*Rate comparison is between the USPS® and FedEx®, UPS® is not included in comparison. UPS® rates, may be viewed separately.



WE'VE GOT YOU COVERED

Quadient maintains a network of offices across the country to provide local customer support and trained technicians who are ready to assist you. You can be confident that when you need knowledgeable support or expert service, the point-of-contact will be a Quadient office in your area consisting of a team of local professionals.

quadient
Because connections matter.

About Quadient®

Quadient is the driving force behind the world's most meaningful customer experiences. By focusing on Intelligent Communication Automation, Parcel Locker Solutions and Mail-Related Solutions, Quadient helps hundreds of thousands of customers worldwide simplify the connection between people and what matters. For more information about our mail-related solutions, visit mail.quadient.com.

Quadient® and the Quadient logo are registered trademarks of Quadient group AG. All other company and product names may be trademarks and are the property of their respective owners. All information in this document, including descriptions of features, functions, performance and specifications is subject to change without written notice at any time. www.quadient.com

WORKING AT THE SPEED OF BUSINESS

Dynamic. User-Focused. Durable.

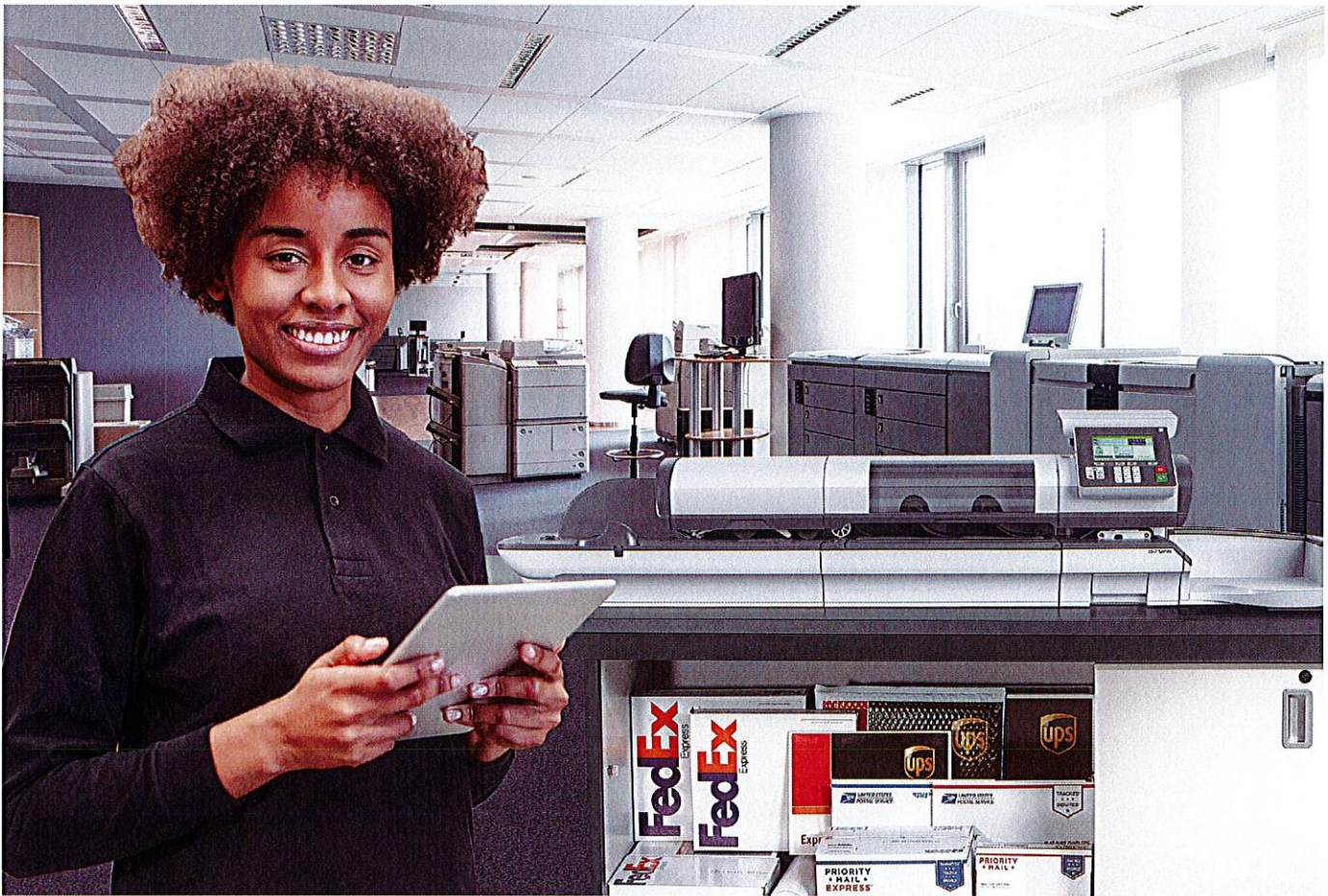

iX-7 Series

The iX-7 Series mailing system is a paramount addition to any business. Built to excel in the most demanding mail centers, the iX-7 Series is available with two different processing speeds and a variety of weighing and stacking options.



EXPERIENCE
A rich history of world-class leadership



PROVEN RESULTS
96% customer satisfaction rate



EXPERTISE
8 billion personalized experiences annually



BACKED BY THE EXPERTS
Gartner, Forrester, and Aspire

INNOVATION DRIVEN BY EXPERIENCE

The contemporary design of the iX-7 Series depicts clean lines, bold edges and an easy to use color touchscreen while maintaining Quadient's commitment to build and ship products in the most ecological manner. The iX-7 Series meets the latest Intelligent Mail Indicia (IMI) and Dimensional Weighing (DIM) USPS® requirements.

1. Mixed Mail Feeder

Processes up to 140 lpm (iX-7);
175 lpm (iX-7PRO)

2. USPS® Based IMI Meter

Ensure compliance with an Intelligent Mail® Indicia (IMI). These meters meet the latest USPS requirements for data and security management.

3. Weighing Platform

10, 30 or 70 lb. platforms handle even the heaviest parcels or oversized packages with ease.

4. Control Panel

A large color touchscreen, intuitive prompts, and shortcut keys make navigation and mail processing a breeze.

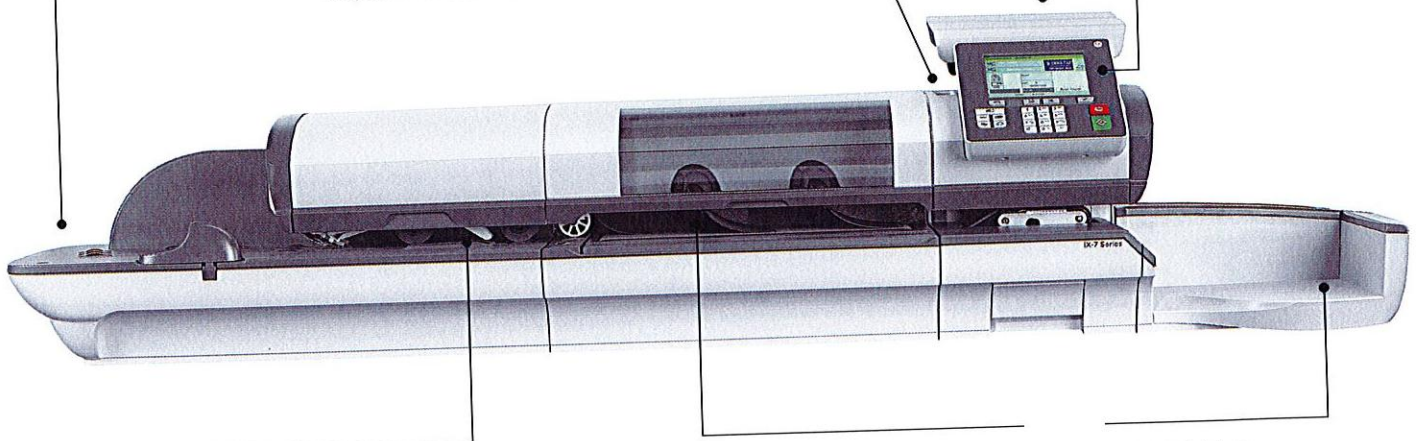

7. Envelope Sealer

Automatic sealing with an easy-access reservoir ensures a perfect envelope seal.

6. Dynamic Scale

Processes up to 75 lpm (iX-7);
up to 110 lpm (iX-7PRO)

5. Catch Tray

From postcards to 10"x13" envelopes, this expandable tray holds a variety of items

MULTI-CARRIER SHIPPING WITH NEOSHIP ADVANCED

Times are changing and businesses want options when it comes to sending parcels. Some companies are extremely loyal to a specific carrier, while others are focused on the bottom line. Hitting a delivery target, or sending an item at the lowest cost are key priorities. Neoship ADVANCED provides the choices businesses are looking for.



- Multi-carrier shipping using USPS®, UPS® and FedEx®
- Cost and time saving opportunities with rate shopping:
 - Neoship automatically identifies the lowest cost or fastest delivery method for getting a parcel to its final destination
- An intuitive interface makes desktop shipping a breeze
- USPS® IM®pb compliant solution
- Discounted postage rates with Commercial Base Pricing
- Free address correction services
- Streamlined shipping workflow with batch processing



MANAGE, CONTROL AND TRACK POSTAGE EXPENSES WITH NEOSTATS

This robust application provides tools to reconcile postage dollars down to 1/10 of a cent in minutes!

- Analyze postage expense data in summary or detailed formats
- Tighten postage forecasting and budgets by understanding postage usage trends on a daily, weekly, or monthly basis
- Optimize potential cost savings by reviewing use of USPS Mail Classes and Weight Break detail
- Create spreadsheets and eye-catching colorful graphs
- Export and share data for additional analysis

This flexible solution supports predefined and user-defined reporting parameters based on Mail Class, Account/Department, Weight Break, Presort and Operator details.

Neostats Enhanced supports a single mailing system. Upgrade to Neostats Consolidated to centralize postage expense data for multiple mailing systems at one location or across many.



SPECIFICATIONS

USPS based IMI meter	Standard
Processing speed iX-7	Up to 140 lpm
Processing speed iX-7PRO	Up to 175 lpm (postcards)
Dynamic weighing speed iX-7	Up to 75 lpm
Dynamic weighing speed iX-7PRO	Up to 110 lpm (postcards)
Color display	Standard
On-screen DIM calculations	Standard
Accounts/departments	100 Standard
Envelope minimum	3.5" X 5"
Envelope maximum	10" x 13"
Envelope thickness	Up to 5/8"
Envelope orientation	Landscape or portrait
Connectivity	LAN Standard
Job imprint memories	9
Neoslogan	Standard
Postage meter tapes	Yes, integrated automatic dispenser
4-digit PIN code	Standard
Neostats Basic postage expense reporting	Standard

OPTIONS

Differential weighing	Available
External weighing platform	Available 10, 30 or 70 lb.
Accounts/departments upgrade	300 or 500
E-Services with Electronic Return Receipt	Available
Neostats Enhanced postage expense reporting	Available
Neostats Consolidated postage expense reporting	Available
Neoship PLUS online shipping software (USPS only)	Available
Neoship ADVANCED multi-carrier online shipping software	Available
IPV6	Available

SYSTEM DIMENSIONS

iX-7 with envelope tray	50" X 18" X 13"
iX-7 with dynamic scale and envelope tray	67" X 18" X 13"

Guided by Quadient's Sustainable Design and Responsible Manufacturing Policy, our products may contain reused components. For more information, visit www.quadient.com/about-us/sustainable-design-and-manufacturing.



About Quadient®

Quadient is the driving force behind the world's most meaningful customer experiences. By focusing on four key solution areas including Customer Experience Management, Business Process Automation, Mail-related Solutions, and Parcel Locker Solutions, Quadient helps simplify the connection between people and what matters. Quadient supports hundreds of thousands of customers worldwide in their quest to create relevant, personalized connections and achieve customer experience excellence. Quadient is listed in compartment B of Euronext Paris (QDT) and belongs to the SBF 120 index.

For more information about Quadient, visit www.quadient.com

Quadient® and the Quadient logo are registered trademarks of Quadient group AG. All other company and product names may be trademarks and are the property of their respective owners. All information in this document, including descriptions of features, functions, performance and specifications is subject to change without written notice at any time.

Get the Postage You Need Now & Pay For It Later

Welcome to the Quadi^{ent} Postage Funding, the easiest way to buy more postage for your Quadi^{ent} mailing system. With Quadi^{ent} Postage Funding, you'll enjoy greater flexibility and control in managing your business and mailing operations.

How does Quadi^{ent} Postage Funding work? It couldn't be simpler. Download postage whenever you need it – there's no need to prepay. We'll pay the Postal Service for your requested postage amount. Each month that you have account activity, you'll receive a Postage Funding invoice that itemizes all of your postage downloads for the billing period. You can take up to 28 days from the statement date to pay by check, ACH, or online.

How much postage can I download? Your account limits are automatically set based on the type of mailing system you have:

Mailing System	Plan Name	Free Transaction Limit	Total Account Limit
Low Volume	Basic PLUS	\$700 per monthly billing period	\$1,500
Mid to High Volume	Advantage PLUS	\$4,000 per monthly billing period	\$8,500

How are transaction fees assessed? You are pre-approved to download up to the Free Transaction Limit amount each month with no fees. If you exceed the Free Transaction Limit during any monthly billing period, the excess amount is subject to a 1% Flex Limit Fee. For example, if your Free Transaction limit is \$4,000 and you add \$5,000 to your postage meter in a single monthly billing cycle, you'll be billed a \$10 Monthly Flex Limit Fee ($\$5,000 - \$4,000 = \$1,000 \times 1\% = \10).

Can I increase the amount of postage available for download from my Postage Funding Account? Yes you can. Simply call our Customer Service Department to arrange an increase in the amount of your Total Account Limit.

Can I choose my statement date and corresponding due date? Yes you can. You may choose a different statement date than the one assigned automatically at the time of enrollment. Approximate statements dates to choose from are the 1st, 5th, 10th, 15th, and 22nd of each month.

Must I pay the entire Postage Funding statement balance by the due date? You must pay at least the minimum payment amount by the due date indicated on your statement. Finance charges may apply for payments that are less than the total balance owed. A late fee may also apply if you do not make the minimum payment by the due date indicated on your bill.

Can I manage my Postage Funding account online? Yes. Simply log into Myquadi^{ent} and you can monitor and track all of your Postage Funding activity. You can also access current and past statements, make online payments and create e-mail alerts.



EXPERIENCE
A rich history of world-class leadership



PROVEN RESULTS
96% customer satisfaction rate



EXPERTISE
8 billion personalized experiences annually



BACKED BY THE EXPERTS
Gartner, Forrester, and Aspire



Quadiant Postage Funding Enrollment with Agreement

Receive a monthly Quadiant Postage Funding invoice and pay on your regular accounting schedule.

- Refill your postage meter as often as you need
- Postage available immediately
- Never run short of postage
- One monthly statement, one monthly payment
- 24/7 online account management tools

Customer Information

Company Name Christian County Missouri
Contact Name
Mailing Address 100 W. Church Street, Room 100
City, St., Zip Ozark, MO 65721

Account Information

POC Account #
Quadiant Postage Funding Plan Advantage PLUS
Quadiant Postage Funding Account Limit \$4,000
Quadiant Postage Funding Total Limit \$8,500

Yes, please enroll me in Quadiant Postage Funding. I acknowledge that I have received, read and agree to all applicable terms and conditions of the Quadiant Postage Funding Account Agreement on the following pages, and that I am authorized to sign the agreements on behalf of the customer identified above.

Signature	Date
Name (Please Print)	Title
Email Address	

Notify me by email when my account is set up.

*Set up of your account may take up to three business days. To ensure continued access to postage, please make sure that sufficient funds are in your POC Account until your enrollment into Quadiant Postage Funding takes effect. Please keep a copy of this Agreement for your records.

It's easy to enroll and get started.

Please submit this form via fax to 800.237.0692 or via email to us.pocadmin@quadiant.com.

Quadiant, Inc. | 478 Wheelers Farms Road | Milford, CT 06461

Quadi^{ent} Postage Funding Account Agreement

- 1. Incorporation of Certain Terms.** This Agreement is by and between Quadi^{ent} Finance USA, Inc. ("Quadi^{ent} Finance") and the Customer identified on the Enrollment Form for this Quadi^{ent} Postage Funding Account Agreement, and sets forth the terms and conditions that apply to a postage funding account as described herein ("Agreement").
- 2. Establishment and Activation of Account.** You hereby authorize Quadi^{ent} Finance, to establish an account in Your name ("Account") for funding the purchase of postage from the United State Postal Service ("USPS") for use in the Postage Meter. Your Account may also be used to purchase supplies, pay for the Postage Meter rental, and obtain certain other products and services from Quadi^{ent}, Inc. The establishment of Your Account shall be subject to Our approval of Your creditworthiness. Any use of the Account shall constitute Your acceptance of all the terms and conditions of this Account Agreement and all other documents executed or provided in connection with the Account. The Account may not be used for personal, family, or household purposes.
- 3. Operation of Account.** Each time an employee or agent of Yours with the express, implied, or apparent authority to do so (each an "Authorized User") uses the Account to receive a postage meter reset or obtain other products or services that Quadi^{ent}, Inc. Inc. is authorized to provide, Quadi^{ent}, Inc. Inc. will notify Us of the amount to be applied to Your Account balance. If the Account is used to obtain postage, then We will transfer the requested amount of postage to the USPS on Your behalf and Your Account will be charged for the amount of postage requested and any related fees, if applicable. You can continue to pre-pay the USPS for postage and understand that pre-paid postage funds will be used first to pay for my postage meter resets. You further understand that the Account will provide additional available postage funds when Your pre-paid account balance is zero (\$0). When You request a Postage Meter reset, if You have the funds on account with the USPS, those funds automatically will be withdrawn first to pay for postage, and any additional amounts due for postage and related fees will be billed through the Account under the terms and conditions of this Account Agreement. If the Account is used to acquire products or services that Quadi^{ent}, Inc. is authorized to provide, then We shall pay the applicable amount to Quadi^{ent}, Inc. Inc. and add such amount to Your Account balance.
- 4. Payment Terms.** You will receive a billing statement for each billing cycle in which You have any activity on Your Account. Payments are due on the due date shown on Your billing statement. You may pay the entire balance due or a portion of the balance, provided that You pay at least the minimum payment amount shown on Your statement. However, if You have exceeded the Account Limit, then You must pay the entire amount of any overage, as well as the minimum payment amount shown on Your statement. Whenever there is an unpaid balance outstanding on Your Account which is not paid in full by the due date shown on Your billing statement, We will charge You, and You agree to pay, interest on the unpaid balance of the Account for each day from the date the transaction is posted to Your Account until the date the unpaid balance is paid in full, at the Annual Percentage Rate (as defined below). The Account balance that is subject to a finance charge each day will include outstanding balances, minus any payments and credits received by Quadi^{ent} Finance on Your Account that day. The Annual Percentage Rate applicable to Your Account will be equal to the lesser of eighteen percent (18.00%) per annum or the maximum permitted by law. Each payment will be applied to reduce the outstanding balance of Your Account and replenish the amount available to You. We may refuse to extend further credit if the amount of a requested charge plus Your existing balance exceeds Your Account Limit.
- 5. Account Limit and Account Fees.** You agree that We will establish a credit limit on Your Account (the "Account Limit"). The exact amount of the Account Limit will be indicated on Your invoice. We may, in Our sole discretion, allow Your balance to exceed the Account Limit. In the event We do so, You agree to pay Quadi^{ent} Finance an additional fee equal to one percent (1%) of the amount by which the Account Limit is exceeded for each transaction that You initiate after Your Account has reached the Account Limit. Such amount will be charged to Your Account on the date that the relevant transaction(s) occurs. Unless prohibited by applicable law, You agree to pay the amounts set forth in this Account Agreement, which may include, without limitation, the amounts specified above, a fee for a late payment, a fee for any checks that are returned as a result of insufficient funds, a fee for any ACH direct debit transactions which are rejected, and an annual account fee. All such fees shall be added to Your Account balance.
- 6. Cancellation and Suspension.** We may at any time close or suspend Your Account or temporarily refuse to allow further charges to Your Account. You can cancel Your Account at any time by notifying Quadi^{ent} Finance in writing at the address provided on Your Account statement of Your desire to do so. No cancellation or suspension will affect Your obligation to pay any amounts You then owe under this Account Agreement. We will notify You of the Account balance in the event of any termination and all outstanding obligations will survive the termination of this Account Agreement by either party.



-
- 7. Default.** We may declare You in default if You: (i) have made any misrepresentations to Quadiant Finance; (ii) at any time, have done or allowed anything that indicates to Quadiant Finance that You may be unable or unwilling to repay the balance of Your Account as required under this Account Agreement; or (iii) are in default under this Account Agreement or any lease, rental, or other agreement with Quadiant Finance, Quadiant, Inc., or their affiliates. If You are in default, or upon any cancellation of Your Account, We shall not be obligated to continue to provide the Account service or extend further credit under this Account Agreement. If We are required to take collection action or any other legal action under this Account Agreement, You shall pay upon demand by Quadiant Finance all court and collection costs, along with reasonable attorney's fees. These remedies shall be cumulative and not exclusive, and shall be in addition to any and all other remedies available to Quadiant Finance.
- 8. Remedies.** If We have declared that You are in default under this Account Agreement, then We may: (i) declare all agreements You have with Quadiant Finance in default and due and payable at once without notice or demand; (ii) refuse to make further advances on Your behalf to reset Your Postage Meter; and (iii) exercise any other rights that We may have. In addition, You agree that any default under this Account Agreement shall constitute a default under any agreement You may have with any of Our affiliates, including, but not limited to, Quadiant, Inc., Quadiant Leasing USA, Inc..
- 9. Amendments.** We may amend this Account Agreement, or any of its provisions, including without limitation any fees and charges and/or the Annual Percentage Rate, at any time by at least thirty (30) days written notice to You, and such written notice may be included in Your billing statement. Any such amendment will become effective on the date stated in the notice and will apply to any transactions after such date, as well as to any outstanding balance on Your Account.
- 10. Notice:** Any notice required to be given under this Account Agreement by either party hereto shall be given if to You, at the address shown on Your Order Form, and if to Quadiant Finance at 478 Wheelers Farms Road, Milford, CT 06461.
- 11. Miscellaneous.** You understand that We may obtain credit reports in connection with Your Account now and in the future. This Account Agreement shall be governed by and construed in accordance with the laws of the State of Texas, without reference to its conflict-of-laws rules, and any applicable federal laws. The sole jurisdiction and venue for actions related to the subject matter hereof shall be in a State or Federal Court within the State of Texas.

Customer

Organization	Christian County Missouri		
DBA			
Address	100 W. Church Street, Room 100		
City State Zip	Ozark	MO	65721
Phone	(417) 582-4309	Fax	

Purchase Order - Lease

NASPO/ValuePoint Contract #: CTR058809
 and / or
 State Participating Addendum (PA) #:
 CC221938008 (MO)

Vendor

Company Name	Quadient Leasing USA Inc. FEDERAL ID# 94-2984624		
Attention	Government Sales	DUNS# 150836872	
Address	478 Wheelers Farms Rd		
City State Zip	Millford	CT	06461
Phone	(866) 448-0045	Fax	(203) 301-2600

Ship To

Organization	Christian County Commission		
Attention	Todd Wiesehan		
Address	1108 W. Jackson Street		
City State Zip	Ozark	MO	65721
Phone	(417) 582-4309	Email	khopkins@christiancountymo.gov

P.O. Number	P.O. Date	Requisitioner	Shipped Via	F.O.B. Point	Terms
			Ground	Destination	Quarterly Invoicing
QTY	Unit	Description	Unit Price	Total	
60	Months	Lease Payment	\$32.19	\$1,931.40	

Lease payment specified above for products listed below includes, as applicable, reduced price equipment maintenance to reflect first year free, meter rental, meter resets, postal rate changes, software license/support/subscription fees, delivery, installation, and operator training.

Products

QTY	Product ID	Description
1	IX1BWP10	IX-1 Base w/ 10lb. Scale - LEASE ONLY, Rate Prot & Post Exp Mgr Incl

- Orders governed under the terms and conditions of the NASPO/ValuePoint Master Price Agreement Contract Number CTR058809. Enter this order in accordance with the prices, terms, delivery method, and specifications listed above.
- Payments will be sent to:
 Quadient Leasing USA Inc.
 Dept 3682
 PO Box 123682
 Dallas TX 75312-3682
- Send all correspondence to:
 Quadient Leasing USA Inc.
 478 Wheelers Farms Rd
 Millford CT 06461

 Authorized by Date

 Print Name Title

BY CHRISTIAN COUNTY AND ONE COPY OF THIS AGREEMENT WILL BE RETURNED TO YOU.

IN WITNESS WHEREOF, the parties have executed and entered into this Agreement as of the date first set forth above.

COUNTY OF CHRISTIAN

CONTRACTOR

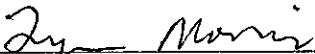
By: 
Lynn Morris, Presiding Commissioner

Company Name: _____

By: 
Bradley A. Jackson, Eastern Commissioner

By: _____

By:  6-13-2023
Hosea Bilyeu, Western Commissioner

Title: _____

By: _____

Title: _____

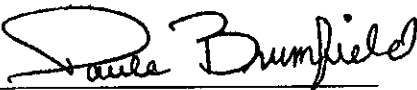
ATTEST BY: 
Paula Brumfield, Christian County Clerk

AUDITOR CERTIFICATION

I certify that the expenditure contemplated by this document is within the purpose of the the document is within the purpose of the appropriation to which it is to be charged and that there is an unencumbered balance of anticipated revenue appropriated for payment of same.

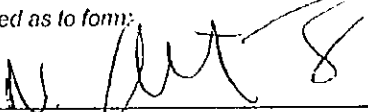
Approved as to form:
By: 
N. Austin Fax, Christian County Counselor

Amy Dent, Christian County Auditor

6.13.2023
Date

BY CHRISTIAN COUNTY AND ONE COPY OF THIS AGREEMENT WILL BE RETURNED TO YOU.

IN WITNESS WHEREOF, the parties have executed and entered into this Agreement as of the date first set forth above.

COUNTY OF CHRISTIAN

CONTRACTOR

By: 
Lynn Morris, Presiding Commissioner

Company Name: _____

By: 
Bradley A. Jackson, Eastern Commissioner

By: _____

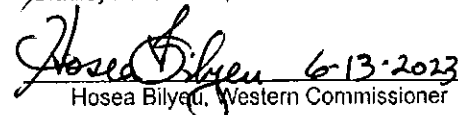
By:  6-13-2023
Hosea Bilyeu, Western Commissioner

Title: _____

By: _____

Title: _____

AUDITOR CERTIFICATION

ATTEST BY: 
Paula Brunelle, Christian County Clerk

I certify that the expenditure contemplated by this document is within the purpose of the appropriation to which it is to be charged and that there is an unencumbered balance of anticipated revenue appropriated for payment of same.

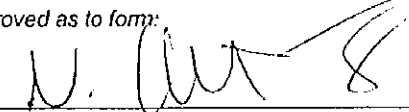
Approved as to form:
By: 
N. Austin Fax, Christian County Counselor

Amy Dent, Christian County Auditor

6.13.2023
Date

Lease Option			
Machine	60-month lease	48-month lease	36-month lease
iX-7DS Mailing System	\$360.61 per month	\$391.95 per month	\$444.79 per month
iX-7DS Mailing System	\$360.61 per month	\$391.95 per month	\$444.79 per month
iX-1 Mailing System***	\$32.19 per month	\$34.55 per month	\$38.52 per month

iX-1 can only be leased because the meter is inside of the machine and is USPS Property

Full-Term All-Inclusive Lease Cost (with estimated supplies)			
Machine	60-month lease	48-month lease	36-month lease
iX-7DS Mailing System	\$22,636.60	\$21,549.60	\$18,064.44
iX-7DS Mailing System	\$22,636.60	\$21,549.60	\$18,064.44
iX-1 Mailing System***	\$3,881.40	\$2,048.40	\$1,776.72

Supplies		
Supplies	Cost	Yield
Meter Tape	\$40 per box	300 per pack
iX-7 Ink Cartridge	\$242 per cartridge	26,000 imprints
iX-1 Cartridge	\$130 per cartridge	1,300 imprints
Average Annual Volume		
72,070 pieces		

Estimated Annual Consumables Cost	# of supplies	Annual Cost
Meter Tape	10	\$400
iX-7 Ink Cartridge	4	\$968
iX-1 Cartridge	3	\$390

Purchase Option	
Machine	Purchase Price
iX-7DS Mailing System	\$9,420
iX-7DS Mailing System	\$9,420

Per iX-7DS	Cost	Annual meter Rental
Year 1 Maintenance	FREE	\$900
Year 2 Maintenance	\$1,570.80	\$900
Year 3 Maintenance	\$1,727.96	\$900
Year 4 Maintenance	\$1,900.76	\$900
Year 5 Maintenance	\$2,090.84	\$900
Total MA Cost over 5 years	\$7,290.36	\$4,500

Total Cost Over 5 Years (per iX-7DS)	\$24,630.36
--------------------------------------	-------------

Memorandum of Understanding

January 1, 2023 – December 31, 2023

THIS AGREEMENT is entered into between Missouri Office of Prosecution Services, hereinafter “MOPS”, and the Prosecuting Attorney’s Office of **Christian County**, Missouri, hereinafter “COUNTY”, and

WHEREAS, Section 56.750(6), RSMo provides that MOPS shall assist the prosecuting attorneys throughout the state in their efforts against criminal activity in the state, and

WHEREAS, the use of email communication is an integral tool for the day to day operations of a modern prosecutors’ office in combatting criminal activity; and

WHEREAS, the Missouri Association of Prosecuting Attorneys (MAPA) Board of Directors and the Prosecutors Coordinators’ Training Council has adopted the policy to develop a statewide email system for prosecutors’ offices, and

WHEREAS, the State of Missouri, through MOPS, has entered into a contract with Karpel Solutions to provide a secure email system to prosecutors via Microsoft 365;

THEREFORE, the parties agree as follows:

1. That COUNTY agrees to utilize the Microsoft Office 365 email system as the sole email within its office when transmitting any case sensitive information, protected criminal history data, victim or witness personal identification information or engaging in any electronic communications involving records that are closed under law;
2. That COUNTY agrees to provide an authorized single point of contact to interface support issues and requests to MOPS;
3. That COUNTY agrees to provide MOPS with an authorized legal search requestor;
4. MOPS agrees to designate a single point of contact with PROVIDER who will request legal searches from PROVIDER on behalf of the County only upon written request from the County authorized legal search requestor;
5. That COUNTY agrees to notify MOPS immediately if any malware or other security related issues involving email occur;
6. That COUNTY agrees to maintain current antivirus updates/software approved by MOPS on systems used to interface with or access Exchange email mailboxes;
7. That for calendar year 2023 the COUNTY is authorized for 34 users to be covered by MOPS under this agreement. The COUNTY is solely responsible for the expense of any other users that fall outside of the authorized user amount stated above;

8. That COUNTY shall not add any users without the express approval of MOPS;
9. This agreement shall be in effect from January 1, 2023 to December 31, 2023;
10. That the COUNTY agrees to comply with any and all security requirements adopted by MOPS upon notification of adoption. Such security requirements may be developed from recommendations from the Missouri Association of Prosecuting Attorneys (MAPA) Steering Committee on Case Management System and/or adopted by the MAPA Board of Directors and the Prosecutors Coordinators' Training Council;
11. That if, in the judgment of MOPS, the COUNTY has not met the requirements of paragraph 10, MOPS reserves the right to terminate this MOU and terminate the COUNTY's user emails provided by PROVIDER after providing thirty (30) days written notice to COUNTY;
12. That such notice under paragraph 11 may only be given if MOPS has provided COUNTY with a written demand to correct the violations in paragraph 10 and has provided COUNTY with 30 days in which to comply;
13. That this agreement supersedes all other agreements, either written or oral, between MOPS and COUNTY relating to emails;
14. That either party may terminate this agreement upon thirty (30) days written notice to the other party;
15. The laws of the State of Missouri shall govern this agreement.

WHEREFORE, we have hereunto set our hands this 31st day of May, 2023.

Darrell Moore
Executive Director
Missouri Office of Prosecution Services

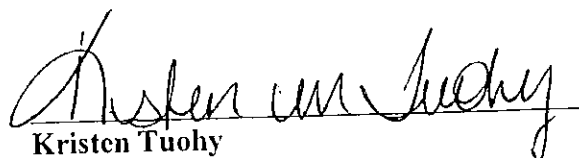
Kristen Tuohy
Prosecuting Attorney
Christian County

Missouri Office of Prosecution Services

PO Box 899
Jefferson City, MO 65102
Phone: (573) 751-0619

Bill To:

DATE:

April 20, 2023

Kristen Tuohy
Christian County Prosecutor's Office
102 W. Walnut St., 1st Floor
Ozark, MO 65721

DESCRIPTION	AMOUNT
2023 Office 365 Email Only (G2) License Fee for <u>2</u> Users (\$96.00/user/year)	\$192.00
2023 Office 365 Full Suite (E3) License Fee for <u>32</u> Users (\$240.00/user/year)	\$7,680.00
TOTAL DUE BY: 5/12/2023	\$7,872.00

Make checks payable to **MOPS**

Please mail payment to the address listed above.

If you have any questions concerning this invoice,
contact Thomas Clinton,
at (573) 522-1838

MOU

IN WITNESS WHEREOF, the parties hereto have hereunto set their hands and affixed their seals this 13 day of JUNE, 2023 at Christian County, Missouri.

DATED: 6-13-23

Lynn Morris
Lynn Morris, Presiding Commissioner

DATED: 6-13-23

Hosea Bilyeu
Hosea Bilyeu, Western Commissioner

DATED: 6-13-23

Bradley A. Jackson
Bradley A. Jackson, Eastern Commissioner

Attested By:

Paula Brumfield
Paula Brumfield, Christian County Clerk

Auditor Certification:

I certify that the expenditure contemplated by this document is within the purpose of the appropriation to which it is to be charged and that there is an unencumbered balance of anticipated revenue appropriated for payment of same.

Amy Dent by lg
Amy Dent, Christian County Auditor

APPROVED AS TO FORM:

N. Austin Fax
N. Austin Fax, Attorney at Law
901 E. St. Louis Street, 20th Flr.
Springfield, MO 65806
Phone: 417.866.7777 Ext. 253
Fax: 417.866.1752
<http://www.lowtherjohnson.com>

MOU

IN WITNESS WHEREOF, the parties hereto have hereunto set their hands and affixed their seals this 13 day of JUNE, 2023 at Christian County, Missouri.

DATED: 6-13-23

Lynn Morris, Presiding Commissioner

DATED: 6-13-23

Hosea Bilyeu, Western Commissioner

DATED: 6-13-23



Bradley A. Jackson, Eastern Commissioner

Attested By:

Paula Brumfield, Christian County Clerk

Auditor Certification:

I certify that the expenditure contemplated by this document is within the purpose of the appropriation to which it is to be charged and that there is an unencumbered balance of anticipated revenue appropriated for payment of same.

Amy Dent, Christian County Auditor

APPROVED AS TO FORM:

N. Austin Fax, Attorney at Law
901 E. St. Louis Street, 20th Flr.
Springfield, MO 65806
Phone: 417.866.7777 Ext. 253
Fax: 417.866.1752
<http://www.lowtherjohnson.com>